

# Drive functions

Motion Controller

MC 5010	MCS
MC 5005	MC 3001
MC 5004	MC 3603
MC 5004 P STO	



## Imprint

---

Version:  
4th edition, 30.08.2021

Copyright  
by Dr. Fritz Faulhaber GmbH & Co. KG  
Daimlerstr. 23 / 25 · 71101 Schönaich

All rights reserved, including those to the translation.  
No part of this description may be duplicated, reproduced,  
stored in an information system or processed or  
transferred in any other form without prior express written  
permission of Dr. Fritz Faulhaber GmbH & Co. KG.

This document has been prepared with care.  
Dr. Fritz Faulhaber GmbH & Co. KG cannot accept any  
liability for any errors in this document or for the  
consequences of such errors. Equally, no liability can be  
accepted for direct or consequential damages resulting  
from improper use of the equipment.

The relevant regulations regarding safety engineering  
and interference suppression as well as the requirements  
specified in this document are to be noted and followed  
when using the software.

Subject to change without notice.

The respective current version of this technical manual is  
available on FAULHABER's internet site:  
[www.faulhaber.com](http://www.faulhaber.com)

# Content

<b>1</b>	<b>About this document</b>	<b>7</b>
1.1	Validity of this document	7
1.2	Associated documents	7
1.3	Using this document	7
1.4	List of abbreviations	8
1.5	Symbols and designations	9
<b>2</b>	<b>Overview of Motion Controller</b>	<b>10</b>
2.1	Components of the Motion Controller	12
2.2	Configuring the drive - general procedure	14
<b>3</b>	<b>Design of the device control</b>	<b>15</b>
3.1	State machine of the drive	15
3.2	Controlword	17
3.2.1	Examples of command sequences	18
3.2.1.1	Enable Operation	18
3.2.1.2	Resetting the fault state	19
3.2.2	Actuation of a holding brake	19
3.3	Statusword	20
3.4	Drive stop at change of state	22
3.4.1	Stopping the drive and deleting movement commands	22
3.4.2	Interrupting movement tasks	22
3.5	Behavior at the limits of the movement range	23
3.5.1	Limit switch	23
3.5.2	Software Position Limits	23
<b>4</b>	<b>Configuring and starting the drive</b>	<b>24</b>
4.1	Establish connection	24
4.2	Setting the motor type	24
4.3	Configuration of the controller parameters and current limitation values	25
4.3.1	Controller cascade	25
4.3.2	Supported motor range	27
4.3.3	Torque controller	27
4.3.3.1	Configuration	28
4.3.4	Speed controller	31
4.3.4.1	Configuration	32
4.3.4.2	Filter settings	35
4.3.4.3	Monitoring	36
4.3.5	Position controller	38
4.3.5.1	Configuration	38
4.3.5.2	Set-points	38
4.3.5.3	Actual values	39
4.4	Configuration of the profile generator	43
4.5	Voltage output	47
4.6	Setting the sensor inputs	49
4.6.1	Configuring the motor encoder	50
4.6.2	Configuring an additional encoder	52

## Content

4.6.3	Adjusting the Hall sensors .....	54
4.6.3.1	Example: Dynamic Hall sensor adjustment .....	55
4.6.3.2	Example: Static Hall sensor adjustment.....	55
4.6.4	Configuring the PWM input.....	56
4.7	Signal paths .....	57
4.7.1	Selection of the actual values .....	57
4.7.1.1	Examples of the selection of actual values .....	59
4.7.2	Selection of discrete set-points .....	60
4.7.2.1	Examples for selection of discrete set-points.....	60
4.8	Factor Group .....	65
4.8.1	Position Encoder Resolution.....	67
4.8.2	Velocity Encoder Resolution.....	68
4.8.3	Velocity factor .....	68
4.8.4	Gear Ratio.....	69
4.8.5	Feed Constant .....	70
4.8.6	Polarity.....	70
4.8.7	Examples of the factor group .....	71
4.8.7.1	General - conversion of a position.....	71
4.8.7.2	General - conversion of a velocity .....	71
4.8.7.3	Setting a DC motor with incremental encoder without a gearhead within a lead screw system .....	72
4.8.7.4	Setting a DC motor with incremental encoder and gearhead within a lead screw system .....	73
4.8.7.5	Setting the linear motor with analog Hall sensors.....	74
4.9	Configuration of the digital inputs and outputs .....	75
4.9.1	Setting the digital inputs.....	76
4.9.1.1	Setting limit switches and reference switches .....	76
4.9.1.2	General settings of the digital inputs.....	77
4.9.1.3	Configuring digital inputs DigIn1-DigIn3 as connections for an additional encoder .....	78
4.9.2	Directly read the level of the digital inputs and outputs, or directly write the digital outputs.....	78
4.9.3	Setting the digital outputs .....	79
4.9.3.1	Setting the fault output .....	79
4.9.3.2	Configuring the digital output as a brake activation .....	79
4.9.3.3	Set a digital output as a diagnostic output .....	79
4.9.3.4	Configuring the polarity of the digital outputs .....	80
4.9.4	Setting the digital input as a touch probe .....	80
4.10	Configuration of analog inputs .....	83
4.10.1	Simulating analog input values .....	85
4.10.2	Using analog inputs as digital inputs .....	86
4.11	Operation with safety function .....	87
4.12	Data record management .....	89
4.12.1	Saving and restoring parameters via the Motion Manager.....	89
4.12.2	Saving the parameter set in the drive .....	89
4.12.3	Restore factory settings.....	90
4.12.4	Switching between different application parameter sets.....	90
<b>5</b>	<b>Selecting the operating mode .....</b>	<b>92</b>
5.1	Starting and switching operating modes .....	94

## Content

5.2	Profile Position mode (PP)	96
5.2.1	Basic function	96
5.2.2	Statusword/Controlword Profile Position mode	98
5.2.3	Control structure for position controller	99
5.2.4	Combined speed profiles	100
5.2.4.1	Specifying a single position set-point	101
5.2.4.2	Specifying multiple set-points in succession (Set of set-points)	102
5.2.4.3	Specifying multiple position set-points with direct transition (Change on set-point)	104
5.2.5	Examples	106
5.2.5.1	Example: Specification of multiple position set-points	106
5.2.5.2	Example: Positioning with absolute set-points, followed by reversing	107
5.2.5.3	Example: Positioning with relative set-points, followed by reversing	108
5.2.5.4	Example: Combined movement	110
5.3	Profile Velocity mode (PV)	112
5.3.1	Basic function	112
5.3.2	Statusword/Controlword Profile Velocity mode	113
5.3.3	Controller structure for speed controller	114
5.3.4	Examples	115
5.3.4.1	Example 1 (reversing operation with a jerk-limited profile)	115
5.3.4.2	Example 2 (acceleration from an existing movement with a limited acceleration rate)	116
5.4	Homing mode	117
5.4.1	Homing Methods	118
5.4.2	Statusword/Controlword Homing mode	125
5.4.3	Settings	126
5.4.4	Example of a homing reference run	127
5.5	Cyclic Synchronous Position mode (CSP)	128
5.5.1	Basic function	128
5.5.2	Statusword/controlword Cyclic Synchronous Position mode	130
5.5.3	Control structure in Cyclic Synchronous Position mode	131
5.5.4	Example	131
5.5.5	Options for operation with cyclical position	132
5.6	Cyclic Synchronous Velocity mode (CSV)	134
5.6.1	Basic function	134
5.6.2	Statusword/Controlword Cyclic Synchronous Velocity mode	135
5.6.3	Control structure in Cyclic Synchronous Velocity mode	135
5.6.4	Example	136
5.7	Cyclic Synchronous Torque mode (CST)	137
5.7.1	Basic function	137
5.7.2	Statusword/Controlword CST	138
5.7.3	Control structure in Cyclic Synchronous Torque mode	138
5.7.4	Example	139
5.8	Voltage Mode	140
5.8.1	Basic function	140
5.8.2	Statusword/Controlword Voltage mode	141

# Content

5.8.3	Settings .....	141
5.8.4	Example .....	142
5.9	Analog Position Control mode (APC) .....	143
5.9.1	Basic function .....	143
5.9.2	Controlword/statusword for Analog Position Control mode.....	144
5.9.3	Settings .....	144
5.9.4	Examples.....	145
5.9.4.1	Specification of a target position for a servo drive via an analog voltage .....	145
5.9.4.2	Specification of a position on an actuator via a pulse/direction signal .....	145
5.10	Analog Velocity Control mode (AVC) .....	146
5.10.1	Basic function .....	146
5.10.2	Controlword/statusword for Analog Velocity Control mode.....	147
5.10.3	Settings .....	148
5.10.4	Example .....	148
5.11	Analog Torque Control mode (ATC) .....	149
5.11.1	Basic function .....	149
5.11.2	Controlword/statusword for Analog Torque Control mode .....	150
5.11.3	Settings .....	150
5.11.4	Example .....	151
<b>6</b>	<b>Protection and monitoring devices .....</b>	<b>152</b>
6.1	Overtemperature protection .....	152
6.2	Force or torque limitation .....	153
6.3	Checking the power supplies .....	154
6.3.1	Undervoltage monitoring .....	155
6.3.2	Overvoltage control.....	155
<b>7</b>	<b>Diagnosis .....</b>	<b>156</b>
7.1	Device monitoring .....	156
7.1.1	Device statusword 0x2324.01 .....	157
7.1.2	Status port .....	158
7.1.3	Additional bits in Statusword 0x6041 .....	158
7.2	Error handling .....	159
7.2.1	Error handling to according CiA 402 (servo drive profile).....	160
7.2.2	Error handling with the FAULHABER error word .....	161
7.2.2.1	Switching off the error response of the drive .....	163
7.2.2.2	Setting the error response fault pin .....	164
7.3	Dispatching error messages .....	165
7.3.1	Error register 0x1001 and error log 0x1003 .....	166
7.3.2	Communication Settings .....	167
7.4	Indication of the dynamic state via the status LED .....	167
<b>8</b>	<b>Parameter description .....</b>	<b>168</b>
8.1	Manufacturer-specific objects .....	168
8.2	Objects of the drive profile acc. to CiA 402 .....	186

## About this document

# 1 About this document

## 1.1 Validity of this document

This document describes:

- Principle of the device control
- Commissioning and configuring the device
- Operating modes and functions

This document is intended for use by technicians and engineers in the application of controlled electrical drives and industrial communications systems.

All data in this document relate to the standard versions of the drives. Changes relating to customer-specific versions can be found in the corresponding data sheet.

All data in this document relate to the firmware revision J.

## 1.2 Associated documents

For certain actions during commissioning and operation of FAULHABER products additional information from the following manuals is useful:

Manual	Description
Motion Manager 6	Operating instructions for FAULHABER Motion Manager PC software
Quick start guide	Description of the first steps for commissioning and operation of FAULHABER Motion Controllers
Communications manual	Description of communication with the drive
Technical manual	Instructions for installation and use of the FAULHABER Motion Controller

These manuals can be downloaded in pdf format from the web page [www.faulhaber.com/manuals](http://www.faulhaber.com/manuals).

You can find further information at [www.faulhaber.com/en/support/technical-support/drive-electronics](http://www.faulhaber.com/en/support/technical-support/drive-electronics).

## 1.3 Using this document

- ▶ Read the document carefully before undertaking configuration.
- ▶ Retain the document throughout the entire working life of the product.
- ▶ Keep the document accessible to the operating personnel at all times.
- ▶ Pass the document on to any subsequent owner or user of the product.

## About this document

### 1.4 List of abbreviations

Abbreviation	Meaning
ADC	Analog-to-Digital Converter
AES	Absolute encoder
AnIn	Analog input
APC	Analog Position Control
ATC	Analog Torque Control
Attr.	Attribute
AVC	Analog Velocity Control
BL	Brushless
BLDC	Brushless DC-motor
CAN	Controller Area Network
CiA	CAN in Automation e.V.
const	Access right "read only" set to constant value
CSP	Cyclic Synchronous Position
CST	Cyclic Synchronous Torque
CSV	Cyclic Synchronous Velocity
DC	Direct Current
DigIn	Digital input
EMF	Back-induced electromotive force
HW	Hardware
Ixx	Data Type Integer (whole numbers) with bit size xx
LM	Linear Motor
LSS	Layer Setting Service
PP	Profile Position
PV	Profile Velocity
ro	read only
rw	read-write
PWM	Pulse Width Modulation
SSI	Synchronous Serial Interface for Position Encoder
STO	Safe Torque Off
Sxx	Data type signed (negative and positive numbers) with bit size xx
TTL	Transistor Transistor Logic
Uxx	Data type unsigned (positive numbers) with bit size xx
VM	Voltage Mode
wo	write only
XDC	External Document Converter
XML	Extensible Markup Language



## About this document

---

### 1.5 Symbols and designations



#### **WARNING!**

Danger with medium level of risk: if not avoided, death or serious injury may result.

- ▶ Measures for avoidance



#### **CAUTION!**

Hazards due to hot surfaces. Disregard may lead to burns.

- ▶ Measures for avoidance



#### **NOTICE!**

Risk of damage.

- ▶ Measures for avoidance



Instructions for understanding or optimizing the operational procedures

- ✓ Pre-requirement for a requested action

1. First step for a requested action

-  Result of a step

2. Second step of a requested action

-  Result of an action

- ▶ Request for a single-step action

## Overview of Motion Controller

### 2 Overview of Motion Controller

The Motion Controller offers flexible integrated control of DC, BL and LM servomotors.

#### Application types

The Motion Controller can be operated as a stand-alone controller or in a network at a master controller or PLC.

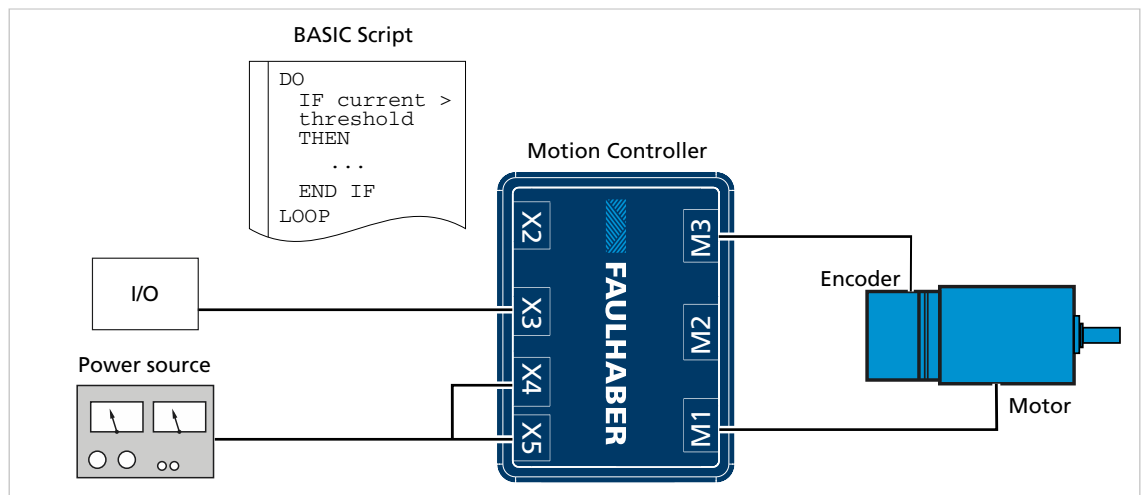

Fig. 1: Motion Controller as stand-alone controller

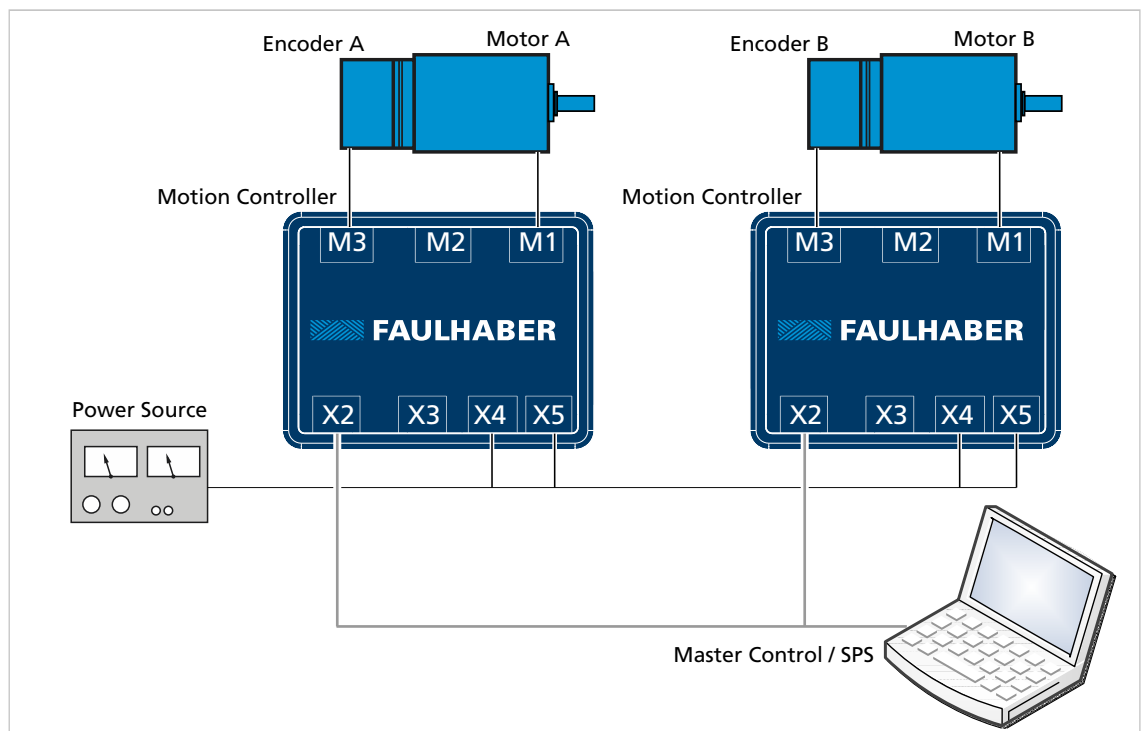

Fig. 2: Motion Controller in a network of a master controller or PLC

## Overview of Motion Controller

### Motion Controller sub-functions

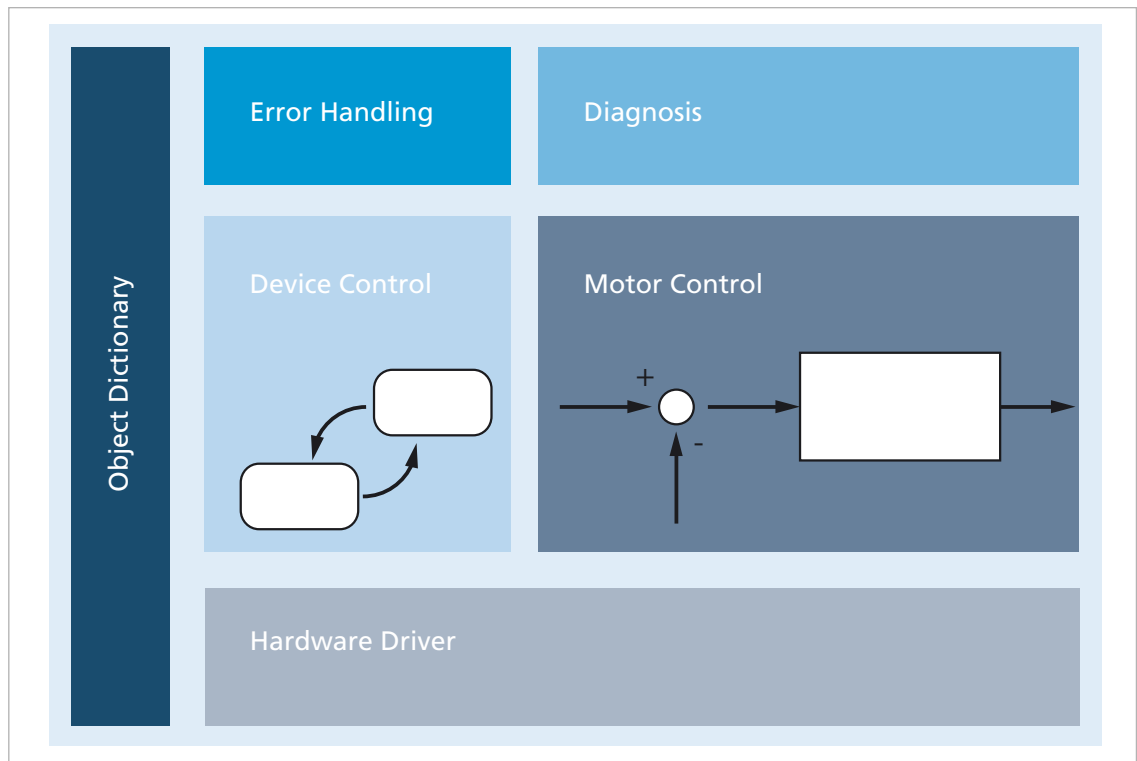

Fig. 3: Motion Controller sub-functions

FAULHABER Motion Controller has several sub-functions:

- **HW driver:** The HW driver provides basic functions for accessing the connected hardware. The parameters include, e.g., the type of the motor encoder or the configuration of the digital inputs.
- **Device control:** The device control contains the drive state machine, switches the output stage and changes the operating modes. The essential parameters are the controlword and the statusword of the drive and the operating mode.
- **Controller:** The controller determines the control for the connected motor from the set-points and actual values. The essential parameters are the settings for the controllers and for the profile generator.
- **Device diagnostics:** Monitors the state of the device and of the connected motor. The essential parameters are the data of the connected motor. The device state is signaled in the device statusword.
- **Error handling:** The error handling can be adjusted to the errors that are detected.
- **Object dictionary:** Gathers the parameters together with the set-points and actual values of the application for access via the communications system or free procedures within the built-in BASIC environment.

**i** The FAULHABER Motion Manager offers convenient methods for device configuration by means of graphical dialogues. Motion Controllers of the V3.0 series with firmware revision J require at a minimum Motion Manager version 6.5.

Configuration can be performed either by direct programming or by other configuration tools.

## Overview of Motion Controller

**i** The basic settings of the Motion Controller must be configured during commissioning, to adapt the controller to the connected motor.

Where integrated drive units (Motion Control Systems) are supplied, the basic configuration has already been performed in the factory. The basic configuration still has to be adapted to the application situation. The following settings often have to be adapted to the application situation:

- Operating mode
- Current limitation values
- Controller parameters
- Function of the digital inputs/outputs

### 2.1 Components of the Motion Controller

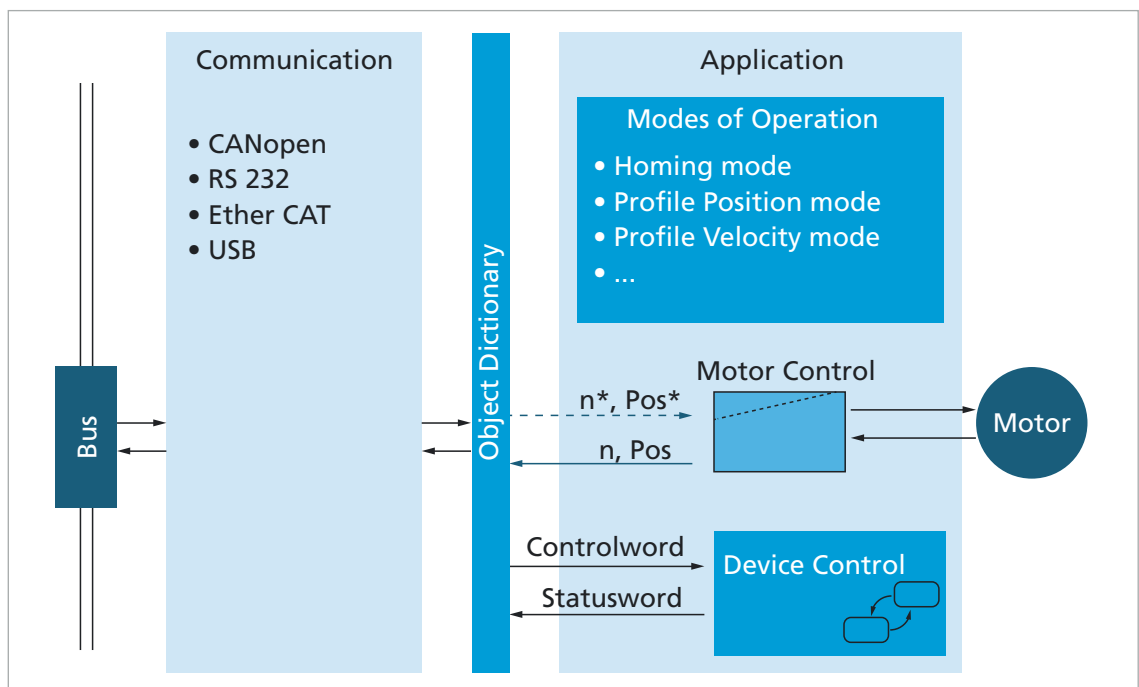

Fig. 4: Basic design of the device control

#### Communication services

The master communicates via the bus system and uses the communication services and the object dictionary (see the Communications manual).

## Overview of Motion Controller

### Object dictionary

The object dictionary contains parameters, set-points and actual values of a drive. The object dictionary is the link between the application (drive functions) and the communication services. All objects in the object dictionary can be addressed by a 16-bit index number (0x1000 to 0x6FFF) and an 8-bit subindex (0x00 to 0xFF).

Index	Assignment of the objects
0x1000 to 0x1FFF	Communication objects
0x2000 to 0x5FFF	Manufacturer-specific objects
0x6000 to 0x6FFF	Objects of the drive profile acc. to CiA 402

The values of the parameters can be changed by the communication side or by the drive side.

### Application part

The application part contains drive functions according to the CANopen servo drive profile acc. to CiA 402. The drive functions read parameters from the object dictionary, obtain the set-points from the object dictionary and return actual values. The parameters from the object dictionary determine the behavior of the drive.

*Tab. 1: Application systems acc. to CiA 402*

Control component	Description
CiA 402 drive state machine	Represents the behavior of the drive (see chap. 3.1, p. 15).
Controlword	Controls the drive behavior (see chap. 3.2, p. 17).
Statusword	Reads the drive behavior (see chap. 3.3, p. 20).

## Overview of Motion Controller

### 2.2 Configuring the drive - general procedure

**i** Steps 1, 2, 3 and 9 are essential in order to commission the drive. In operating modes PP and PV, step 4 must be performed in order to set the profile generators.

FAULHABER Motion Manager 6 offers helpful commissioning wizards for steps 1-4. Appropriate graphical communications dialogues are provided for the further steps.

The other steps allow the end application to be configured.

#### Procedure for initial commissioning

- ✓ Have a suitable tool to hand (such as the FAULHABER Motion Manager or other configuration tools).
- ✓ The communication settings must be correct, see the Communications manual.
- 1. Establish connection (see chap. 4.1, p. 24).
- 2. Set the motor type and motor data (see chap. 4.2, p. 24).
- 3. Adjust the controller parameters and current limitation values to the motor type and application (see chap. 4.3, p. 25).
- 4. Set the profile generator (see chap. 4.4, p. 43).
- 5. Set error handling (see chap. 7, p. 156)
- 6. Set the digital inputs and outputs (see chap. 4.9, p. 75).
- 7. Convert the units (see chap. 4.8, p. 65).
- 8. Set the actual value source (see chap. 4.7, p. 57).
- 9. Set the operating mode (see chap. 5, p. 92).

## Design of the device control

### 3 Design of the device control

#### 3.1 State machine of the drive

During the switch-on and switch-off process, the FAULHABER Motion Controller passes through a state machine with several steps. The sequence corresponds to the process defined in the CiA 402 for CANopen drives.

The transitions are controlled by the controlword (object 0x6040) of the drive.

The drive behavior is represented by a state machine. The controlword controls the transitions, the statusword shows the states.

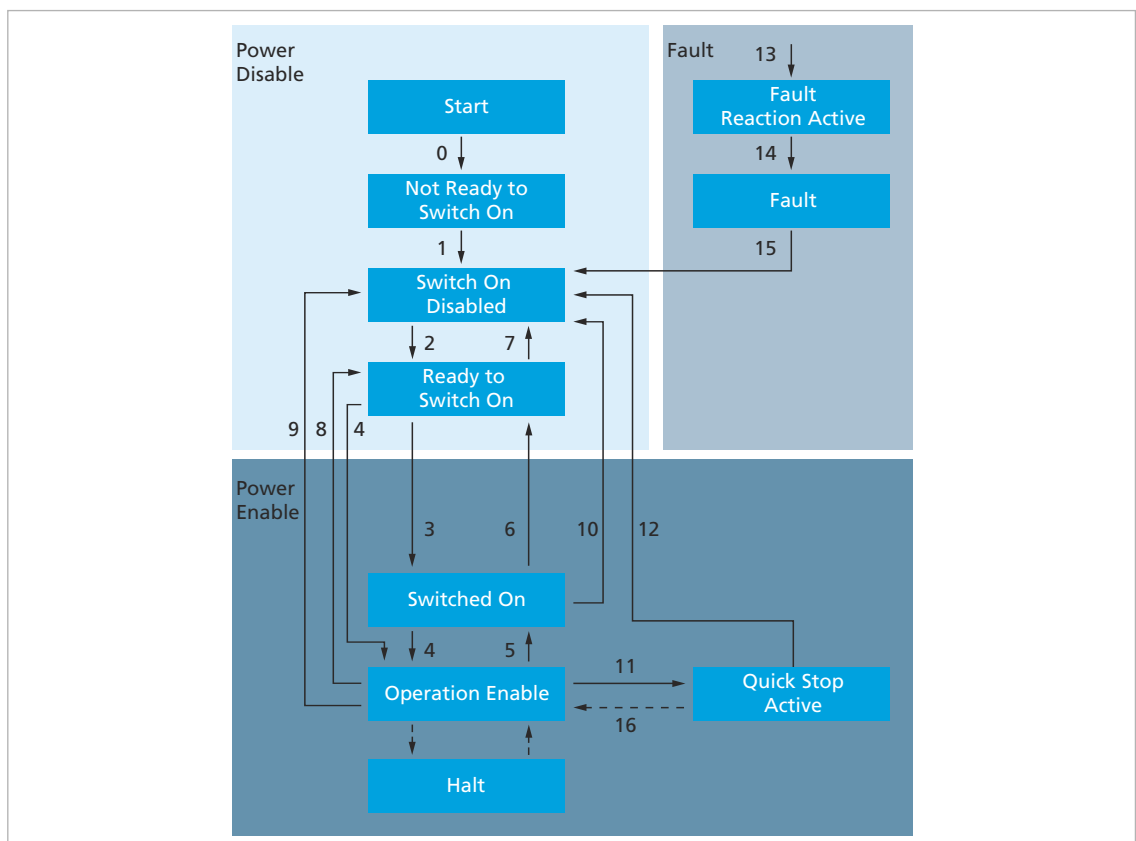

Fig. 5: State machine of the drive

Tab. 2: Command overview

Command	Transitions
Shut Down	2, 6, 8
Switch On	3
Disable Voltage	7, 9, 10, 12
Quick Stop	11
Disable Operation	5
Enable Operation	4, 16
Fault Reset	15

## Design of the device control

---

- The *Not Ready to Switch On* state is passed through automatically. The Motion Controller can be configured via the object 0x2503 so that the offsets for the current measurement are automatically readjusted.
- After it has been switched on, the drive is in the *Switch On Disabled* state. The status LED starts to flash green.
- The **Shut down** command brings the drive into the *Ready to Switch On* state. The option code in the object 0x605B can be used to specify whether the drive should first be brought to a controlled stop.
- The **Switch On** command switches the Motion Controller into the *Switched On* state. The *Switched On* state can be passed through automatically if in the *Ready to Switch On* state the **Enable Operation** command is given directly.
- The **Enable Operation** command brings the drive into the *Operation Enabled* state. The transition is performed only if the power supply is within the permissible range. If a digital output is configured for actuation of the holding brake, the holding brake is first released.
- The output stage is enabled in the *Operation Enabled* state. The status LED lights up continuously green. The behavior of the controller depends on the set operating mode.
- The **Disable Operation** command returns the drive to the *Switched On* state. All movement commands outstanding at this stage are cancelled. If a holding brake is configured, it is applied before the output stage is switched off. The option code in the object 0x605C can be used to specify whether the drive should first be brought to a controlled stop.
- The **Disable Voltage** command switches the output stage off directly. The motor is not braked. If a holding brake is configured, it is applied before the output stage is switched off. The drive is then in the *Switch On Disabled* state.
- The **Quick Stop** command changes the drive from the *Operation Enabled* state to the *Quick Stop Active* state. The option code in the object 0x605A can be used to specify how a motor that is still running can then be brought to a standstill. Any outstanding movement commands are discarded when the *Quick Stop Active* state is entered. The brake is not activated if the drive remains in the *Quick Stop Active* state.
- The halt bit in the controlword allows a drive to be stopped during the course of a movement. The current and following movement jobs are not discarded but merely suspended as long as the halt bit is set. The movement jobs are resumed as soon as the halt bit is unset.
- Sending the **Enable Operation** command again activates the drive again from the *Quick Stop Active* state. This resets the set-point, and the position previously attained is retained.
- In response to detection of an error the drive can switch from any state into the Fault state. The option code in the object 0x605E can be used to specify how a motor that is still running can then be brought to a standstill. After this the output stage will be switched off and a configured holding brake is applied.



## Design of the device control

### 3.2 Controlword

The commands for performing a change of state are defined by combinations of bits 0–3 in the controlword. The controlword is located in the object dictionary under index 0x6040.

#### Controlword

Index	Subindex	Name	Type	Attr.	Default value	Meaning
0x6040	0x00	Controlword	U16	rw	–	Drive control

Tab. 3: Overview of the bits of the controlword and combination possibilities of bits 0-3

Bit	Function	Commands for the device control state machine						
		Shut Down	Switch On	Disable Voltage	Quick Stop	Disable Operation	Enable Operation	Fault Reset
0	Switch On	0	1	X	X	1	1	X
1	Enable Voltage	1	1	0	1	1	1	X
2	Quick Stop	1	1	X	0	1	1	X
3	Enable Operation	X	0	X	X	0	1	X
4	Operation Mode Specific							
5	Operation Mode Specific							
6	Operation Mode Specific							
7	Fault Reset							0 → 1
8	Halt							
9	Change on set-point (only in Profile position mode)							
10	Not used							
11	Not used							
12	Not used							
13	Not used							
14	Not used							
15	Not used							

- 1 = Bit set
- 0 = Bit not set
- 0 → 1 = rising edge, change from 0 to 1
- X = Bit not used for this command (state irrelevant)

## Design of the device control

Tab. 4: Meaning of the bits in the controlword

Bit	Function	Description
0	Switch On	0: No voltage present 1: Power supply is activated
1	Enable Voltage	0: Drive switched off 1: Drive ready
2	Quick Stop	0: Quick stop enabled 1: Quick stop disabled
3	Enable Operation	0: Operation disabled 1: Operation enabled
7	Fault Reset	0 → 1: Reset error
8	Halt	0: Movement can be executed 1: Stop drive

### 3.2.1 Examples of command sequences

The command sequences for controlling the state machine are explained in the following sections.

#### 3.2.1.1 Enable Operation

Step sequence of the transitions to bring a drive into the *Operation Enabled* state.

- ✓ The drive is in the *Switch On Disabled* state.
- 1. Send the Shutdown command (controlword = 0x00 06).
  - ↪ The drive switches into the *Ready to Switch On* state.
- 2. Send the Switch On command (controlword = 0x00 07).
  - ↪ The drive switches into the *Switched On* state.
- 3. Send the Enable Operation command (controlword = 0x00 0F).
  - ↪ The drive is in the *Operation Enabled* state. In this state the set operating mode can be used, using the respective objects.

## Design of the device control

### 3.2.1.2 Resetting the fault state

Sequence of steps of the transition to bring a drive out of the fault state.

- ✓ The drive is in the *Fault* state.
- 1. Send the Fault Reset command (controlword = 0x00 80).
  - ↪ The drive switches into the *Switch On Disabled* state.
- 2. Send the Shutdown command (controlword = 0x00 06).
  - ↪ The drive switches into the *Ready to Switch On* state.
- 3. Send the Enable Operation command (controlword = 0x00 0F).
  - ↪ The drive is in the *Operation Enabled* state. In this state the set operating mode can be used, using the respective objects.

 The current state of the state machine of the drive (see Fig. 5) can be read from bits 0 to 6 of the statusword.

Only transitions defined in the current states can be performed. Therefore before a change of state, the evaluation of the statusword must be checked in order to determine the state of the drive.

### 3.2.2 Actuation of a holding brake

Using the object 0x2312.02, one of the digital outputs can be defined as a control port for a holding brake. During the transition into the *Operation Enabled* state, the holding brake is released and reactivated before the output stage is switched off again.

The delay time to be applied is set via the object 0x2312.03.

## Design of the device control

### 3.3 Statusword

The current state of the drive is represented in bits 0–6 of the statusword. The statusword is located in the object dictionary under index 0x6041.

#### Statusword

Index	Subindex	Name	Type	Attr.	Default value	Meaning
0x6041	0x00	Statusword	U 16	ro	–	Status display

Tab. 5: Overview of the bits of the statusword and combination possibilities of bits 0-6

Bit	Function	State of the device control state machine							
		Not Ready to Switch On	Switch On Disabled	Ready to Switch On	Switched on	Operation Enabled	Quick Stop Active	Fault Reaction Active	Fault
0	Ready to Switch On	0	0	1	1	1	1	1	0
1	Switched On	0	0	0	1	1	1	1	0
2	Operation Enabled	0	0	0	0	1	1	1	0
3	Fault	0	0	0	0	0	0	1	1
4	*Voltage enabled	X	X	X	X	X	X	X	X
5	Quick Stop	X	X	1	1	1	0	X	X
6	Switch On Disabled	0	1	0	0	0	0	0	0
7	Warning								
8	0								
9	Not used								
10	Operation Mode Specific (see chap. 5, p. 92)								
11	Internal Limit Active								
12	Operation Mode Specific (see chap. 5, p. 92)								
13	Operation Mode Specific (see chap. 5, p. 92)								
14	Configurable								
15	Configurable								

1 = Bit set

0 = Bit not set

X = Bit not used for this command (state irrelevant)

\* = Not implemented. FAULHABER Motion Controllers have no switch for the power supply

## Design of the device control

Tab. 6: Meaning of the bits in the statusword

Bit	Function	Description
0	Ready to Switch On	0: Not ready to switch on 1: Ready to switch on
1	Switched On	0: No voltage present 1: Drive is in the <i>Switched On</i> state
2	Operation Enabled	0: Operation disabled 1: Operation enabled
3	Fault	0: No error present 1: Error present
4	Voltage Enabled <sup>a)</sup>	0: Power supply disabled 1: Power supply enabled
5	Quick Stop	0: Quick stop disabled 1: Quick stop enabled
6	Switch On Disabled	0: Switch on enabled 1: Switch on disabled
7	Warning	0: No raised temperatures 1: One of the monitored temperatures has exceeded at least the warning threshold.
8	0	Not used
9	Remote	Not used
10	Operation Mode Specific	See the respective operating mode
11	Internal Limit Active	0: Internal range limit not reached 1: Internal range limit e.g. limit switch reached
12	Operation Mode Specific	See the respective operating mode
13	Operation Mode Specific	See the respective operating mode
14	Configurable	The object 0x233A.01 can be used to configure which combination of states from the object 0x2324.01 (device statusword) should be shown (see chap. 7, p. 156).
15	Configurable	The object 0x233A.02 can be used to configure which combination of states from the object 0x2324.01 (device statusword) should be shown (see chap. 7, p. 156).

a) FAULHABER Motion Controllers and Motion Control Systems are powered directly by a DC power supply. Bit 4 has thus no meaning.

## Design of the device control

### 3.4 Drive stop at change of state

#### 3.4.1 Stopping the drive and deleting movement commands

When the drive exits the *Operation Enabled* state, it can be required that it is brought to a stop before the output stage is switched off. Possible causes of a change of state are:

- The drive is stopped by the **Quick Stop** command, the control can however remain active.
- The drive is stopped by the **Shutdown, Disable Voltage** or **Disable Operation** command.
- The drive switches into the *Fault* state as a consequence of detecting an error.

When the commands **Quick Stop**, **Shut Down**, **Disable Voltage** and **Disable Operation** are issued, and also during error handling, any outstanding movement commands are cancelled. When the drive is subsequently reactivated, the drive resumes movement only once a new set-point has been input.

Tab. 7: Options for stopping the drive at changes of state

Braking procedure	Quick Stop (0x605A)	Shut Down (0x605B)	Disable Operation (0x605C)	Fault (0x605E)
0 Deactivate directly	x	x	x	x
1 Brake ramp + switch off	x	x	x	x
2 Quick stop ramp + switch off	x	–	–	x
3 Stop with maximum braking current	x	–	–	x
4 Stop with U = 0 + switch off	x	–	–	x
5 Brake ramp + maintain state	x	–	–	–
6 Quick stop ramp + maintain state	x	–	–	–
7 Stop with maximum braking current	x	–	–	–
8 Stop with U = 0 + maintain state	x	–	–	–

 If a holding brake is configured, it is activated before the controller is deactivated.

#### 3.4.2 Interrupting movement tasks

A running movement task can be interrupted via the halt bit in the controlword. If the drive was stopped by the halt bit, the drive immediately resumes the movement it was previously performing as soon as the halt bit is reset.

The reaction of the drive to a halt bit can be configured in object 0x605D:

- 1: Brake ramp + maintain state
- 2: Quick stop ramp + maintain state
- 3: Stop with maximum braking current
- 4: Stop with U = 0 + maintain state

## Design of the device control

### 3.5 Behavior at the limits of the movement range

#### 3.5.1 Limit switch

The digital inputs of the Motion Controller can be configured for evaluation of limit switches (see chap. 4.9.1, p. 76).

The drive will be stopped if it reaches a limit switch during operation. The configuration is performed via the object 0x2310.03.

Index	Subindex	Name	Type	Attr.	Default value	Meaning
0x2310	0x03	Limit Switch Option Code	S16	rw	1	0: Drive comes to a standstill powerlessly 1: Brake ramp 2: Quick Stop 3: Stop at max. current 4: Stop with voltage = 0

 The drive is stopped and the speed is then controlled to = 0.

#### 3.5.2 Software Position Limits

Via the object 0x607D the limits of the movement range can be configured irrespective of the limit switches.

Position set-points via the object 0x607A are always limited to this value range, even in cases of relative positioning in the *Profile Position Mode (PP)* operating mode, no set-points can be set outside the movement range thereby determined.

 Endless positioning, for instance for cyclical conveyor devices is available in the *Profile Position Mode (PP)* operating mode. For this purpose, the Position Range Limit (0x607B) object must be used to reduce the range of the actual values to be smaller than the range specified by the Software Position Limits.

In speed-controlled mode, Software Position Limits can be treated like limit switches. If the upper or lower position limit is violated, the drive is brought to a stop via the ramp defined in the object 0x2310.03.

The reaction to Software Position Limits can be set using the object 0x233F.

- Bit 1 = 0: Software Position Limits have no effect except in positioning mode
- Bit 1 = 1: Software Position Limits are treated like limit switches if not in positioning mode.

## Configuring and starting the drive

### 4 Configuring and starting the drive



#### NOTICE!

Disregarding the basic settings can cause damage to components.

- ▶ Comply with the description of the basic settings.



The steps described below are applicable when the Motion Manager is being used.

#### 4.1 Establish connection

1. Connect the drive to the Motion Controller.
2. Connect the power supply to the Motion Controller.
3. Set the communication interface as specified in the Motion Manager manual and the respective Communications manual.



Depending on the selected communications interface, it may be necessary to set the baud rate and the node number. If other configuration tools are used, the following settings must be performed:

- CANopen: The node number and baud rate are set via the LSS protocol. This can be done using the Motion Manager or any CANopen configuration program (see the CANopen Communications manual).
- RS232: The node number and baud rate are set using the objects 0x2400.02 (baud rate) and 0x2400.03 (node number). The object 0x2400.05 allows a network mode for the RS232 interface to be activated, so that several Motion Controllers can be operated using a single RS232 interface (see the RS232/USB communications manual).
- USB: The node number of the Motion Controller can be set using the object 0x2400.03 (see RS232/USB communications manual).

#### 4.2 Setting the motor type

- ✓ Connection with the Motion Controller established.
- ✓ The Motion Manager is in its latest version.
- ▶ Use the Motion Manager motor wizard to set the connected motor.
  - ↪ The motor is set with all parameters that are necessary for motor protection.

The encoder system connected to the motor is configured.

The controllers are preconfigured for the selected motor type without taking into account the load.



## Configuring and starting the drive

### 4.3 Configuration of the controller parameters and current limitation values

The motor controller ensures that the required set-points are maintained. This is done by comparing the set-points and actual values, and adjusting the operation accordingly. The factor group is used to convert internal position values or speeds into user-defined scaling.

Actual values may be generated by:

- Analog Hall sensors
- Digital Hall sensors
- Incremental encoders
- Absolute encoder
- Tacho generators

Set-point sources may be generated by:

- Set-point objects in the object dictionary
- Analog inputs
- PWM input
- Target position as quadrature or pulse/direction signal

#### 4.3.1 Controller cascade

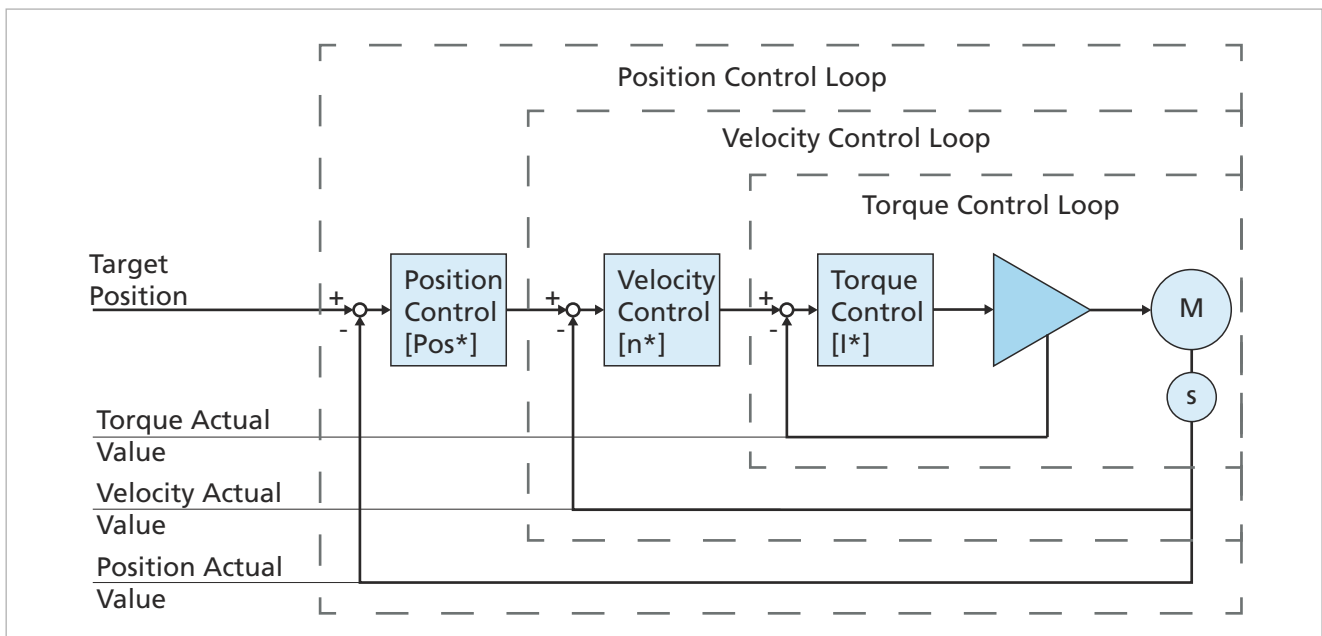



Fig. 6: Controller cascade

## Configuring and starting the drive

The following control loops are configured in a cascade structure in the Motion Controller (see Fig. 6):

- Control loop for torque control  
The innermost control loop controls the torque by means of the motor current (torque controller).
- Control loop for speed control  
The speed control is the middle control loop and, depending on the control deviation of the speed, calls for a target torque, which the subordinate torque controller sets.
- Control loop for position control  
The position controller is the outermost control loop and, depending on the control deviation of the position, calls for a target speed, which the subordinate speed controller sets.

The advantage of the cascade structure is the separate commissioning of each stage. Target value limitations can be set directly within each stage.

 For optimization of the controller, the control loops must be set up, starting with the innermost (torque controller) and proceeding to the outermost (position controller). Various different optimizations are available, depending on the target of the controller.

### Targets of the control process

- Constant torque or constant force
- High speed control (constant motor speed)
- Smooth running of the motor (low-noise)
- High dynamic response when the set-point changes
- High dynamic response to interference
- High positioning accuracy
- Achievement of the target position without overshoot

 Not all the aspects of target control parameters can be achieved with any given group of controller settings. Instructions for optimizing the control parameters can be found in the chapters below for the respective controllers.

### Behavior of the controlled drive in the various operating modes

In operating modes CSP, CSV and CST the set-points for position, speed and torque are output cyclically by a supervisory control and are applied directly to the local control. The higher-level control determines the necessary intermediate values (interpolation) and coordinates the movement with the other drives of the system.

In operating modes PP and PV, the profile generator in the Motion Controller uses the target values for the position and speed and the limit values for the acceleration and speed to autonomously calculate a movement profile, as well as the required time profiles for torque, speed and position. This directly ensures compliance with the following values in the drive:

- Limits of the acceleration or braking deceleration
- The maximum permissible speed

In operating modes APC, AVC and ATC the set-points for the control are set by means of discrete inputs such as an analog input.

## Configuring and starting the drive

### 4.3.2 Supported motor range

The controller systems implemented in the FAULHABER Motion Controllers are optimized for operation of FAULHABER DC, BL-servo and linear motors.

**i** All the supported motors can be called up directly in the Motion Manager motor selection wizard.

In the following cases, motors from other companies can also be operated using the Motion Controller:

- The motor must have a suitable speed sensor and/or position encoder system.
- The value range for the electric motor characteristics is comparable to the motors from the FAULHABER portfolio.

**i** When operating a motor from another company using the Motion Manager, the motor must be added to the motor selection wizard (see the Motion Manager manual).



#### NOTICE!

Operating a motor with incorrectly set control systems can damage the motor or the Motion Controller.

- ▶ Make sure that the motor control settings are correct.

### 4.3.3 Torque controller

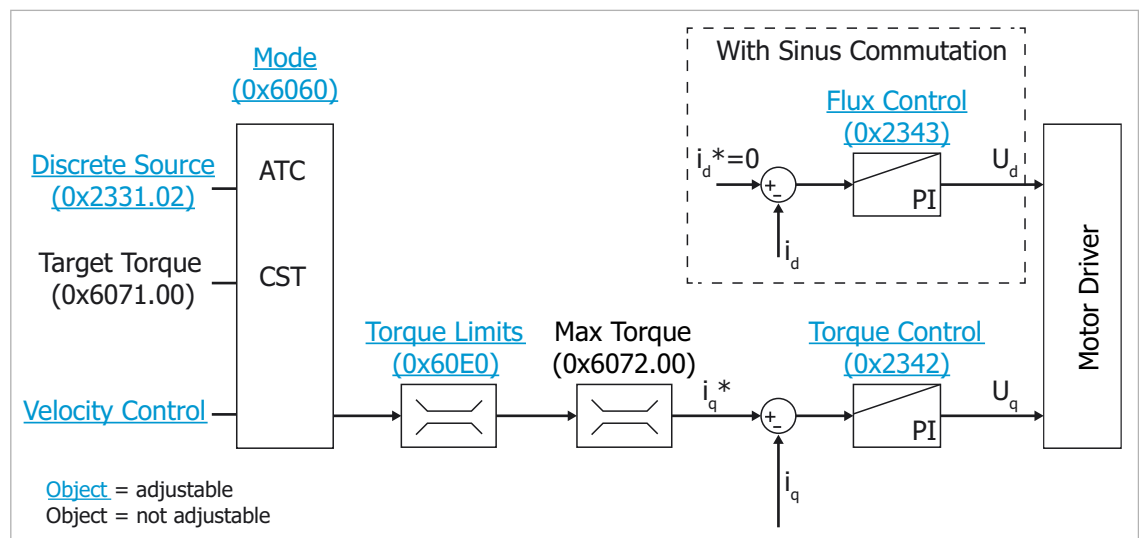

Fig. 7: Motion Manager view of the torque control

For DC motors, the torque controller controls the motor current. For BL motors with sine commutation the torque-generating part of the current  $I_q$  is in phase with the EMF of the motor, and the field-generating part of the current  $I_d$  is controlled separately, in phase with the magnetic field of the rotor. For BL motors with block commutation, the amplitude of the motor current is controlled.

For DC motors and for BL motors with block commutation, the output value of the current control is the value of the motor voltage. For BL motors with sine commutation, the output value of the current control is the value and phase of the motor voltage.

## Configuring and starting the drive

### 4.3.3.1 Configuration

#### Torque controller

The torque controller is implemented as a PI controller for the motor current or for the torque-generating motor current component  $I_q$ .

The relevant parameters are the controller reset time  $T_{N,I}$  in object 0x2342.02 and the controller gain  $K_{P,I}$  in object 0x2342.01.

Tab. 8: Torque control parameter set

Index	Subindex	Name	Type	Attr.	Default value	Meaning
0x2342	0x00	Number of Entries	U8	ro	2	Number of object entries
	0x01	Gain $K_{P,I}$	U32	rw	a)	Controller gain [mOhm]
	0x02	Integral Time $T_{N,I}$	U16	rw	a)	Controller reset time [ $\mu$ s], Range: 150–2600 $\mu$ s

a) Motor-specific, is set by the motor selection wizard.

The Motion Manager motor selection wizard sets the parameters of the torque controller to values optimized for the electrical characteristics of the connected motor.

#### Field controller

For BL motors with sine commutation the part of the current  $I_d$  that is in phase with the magnetic field of the rotor is controlled separately. The settings of the controller can be found in the object 0x2343 and are generally identical to those for the torque controller.

Tab. 9: Flux control parameter set

Index	Subindex	Name	Type	Attr.	Default value	Meaning
0x2343	0x00	Number of Entries	U8	ro	2	Number of object entries
	0x01	Gain $K_{P,I}$	U32	rw	a)	Controller gain [mOhm]
	0x02	Integral Time $T_{N,I}$	U16	rw	a)	Controller reset time [ $\mu$ s], Range: 150–2600 $\mu$ s

a) Motor-specific, is set by the motor selection wizard.

#### Set-points

- In CST operating mode the set-points for the torque controller are determined directly via the communications system (object 0x6071). In operating mode ATC the set-point specification is set via a discrete source, such as an analog input (see chap. 4.9, p. 75 and chap. 4.7, p. 57).
- In operating modes with an active speed controller, the target torque is determined by the speed controller.
- The control is performed using relative values. A set-point of 1000 corresponds to the rated torque of the connected motor.
- The set-point of the field-generating part of the current is generally 0, since for small motors with air gap windings no field-weakening is available.
- A set-point  $\neq 0$  is required for the field controller if the motor supply exceeds the set limit value. Short-term peak currents can be dissipated by this means without affecting the dynamics of the motor.

## Configuring and starting the drive

### Actual values

The torque controller controls the motor current by comparing the actual value to the set-point. The actual value is measured within the device as the motor current.

**i** The best control results are achieved when the motor rated current is greater than 30% of the device rated current (see Tab. 10).

Tab. 10: Example of operation of a 3564K024 B motor with 2.5 A rated current

Motion Controller	Device continuous current	Suitability
MC 5010	10 A	Possible
MC 5005	5 A	Recommended
MC 5004	4 A	Recommended

### Limits

The set-points of the torque controller can be limited using the objects 0x60E0 (Positive Torque Limit Value) and 0x60E1 (Negative Torque Limit Value). In addition the set-point is initially limited to the set peak current. At higher loads on the motor and consequently higher winding temperatures, the set-point is limited to the set continuous current.

The continuous current and peak current of the motor are set by the Motion Manager during commissioning on the basis of the motor data sheet values. Depending on the application these values can or must be adjusted (see chap. 6.1, p. 152).

Tab. 11: Positive torque limit value

Index	Subindex	Name	Type	Attr.	Default value	Meaning
0x60E0	0x00	Positive Torque Limit Value	U16	rw	6000	Upper limit value in relative scaling <sup>a)</sup>

a) 1000 = motor rated torque

Tab. 12: Negative torque limit value

Index	Subindex	Name	Type	Attr.	Default value	Meaning
0x60E1	0x00	Negative Torque Limit Value	U16	rw	6000	Lower limit value in relative scaling <sup>a)</sup>

a) 1000 = motor rated torque

## Configuring and starting the drive

### Optimization of the control

The Motion Manager commissioning wizard has already pre-set the current controller for simple applications. The tools available in the Motion Manager permit manual optimization.

- i** For manual optimization of the current controller, apply set-point jumps to the current controller with the motor braked to a standstill, and adjust the two controller gains  $K_{P,I}$  for torque and field controller via objects 0x2342.01 and 0x2343.01 in a similar manner (see Fig. 8).

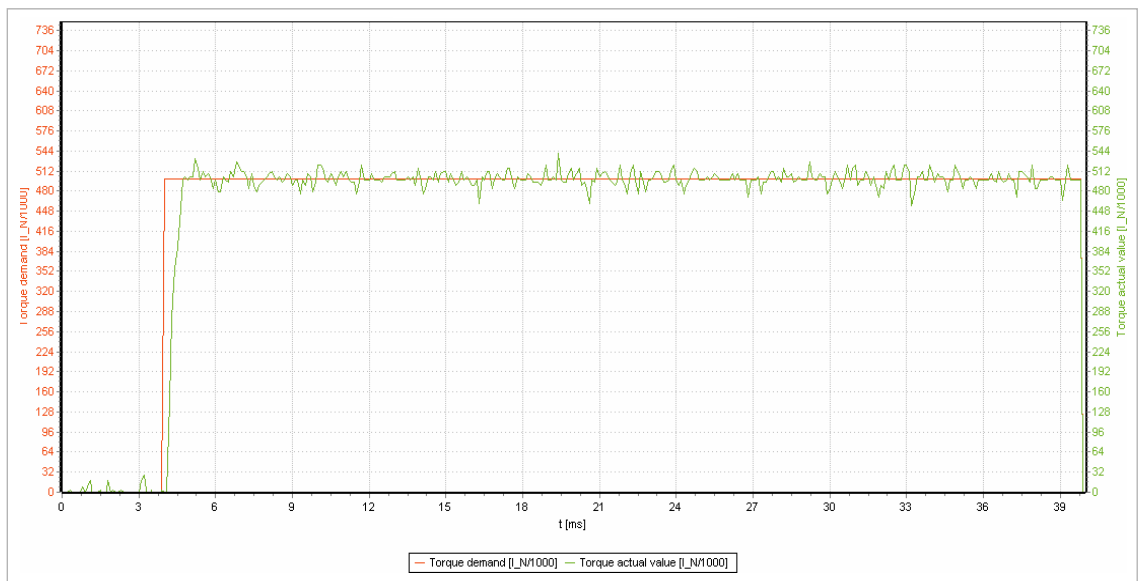

Fig. 8: Set-point jump at the torque control

## Configuring and starting the drive

### 4.3.4 Speed controller

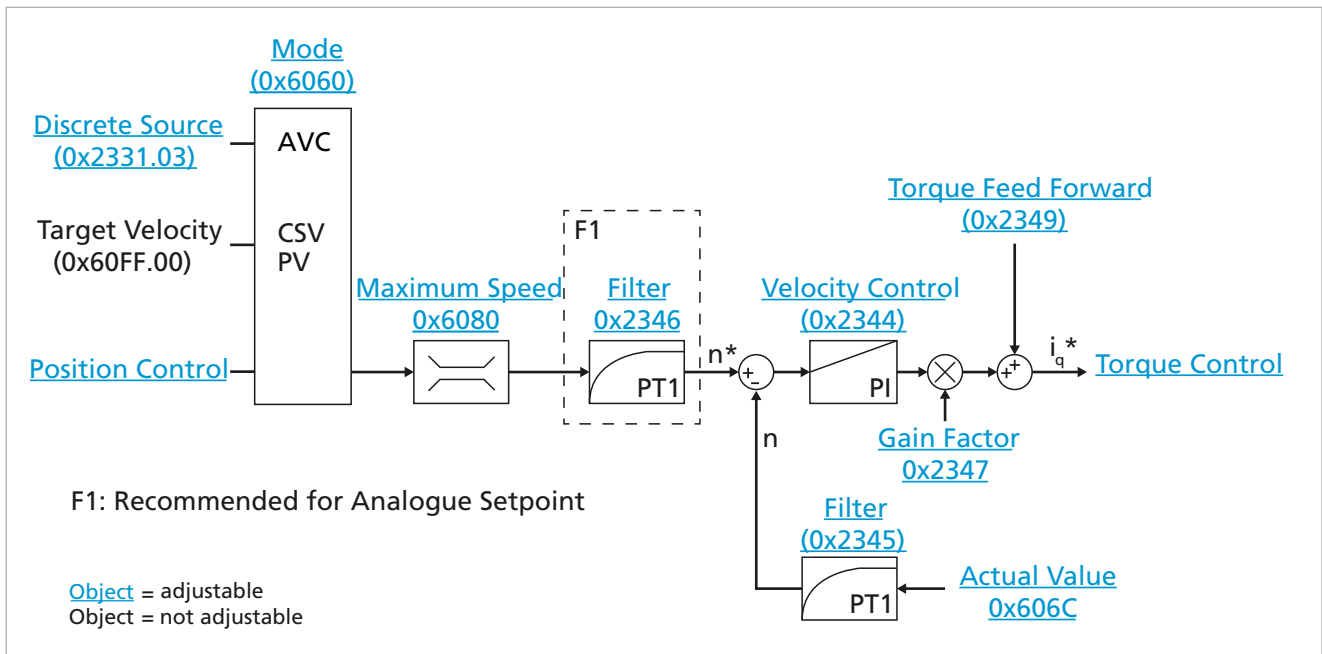

Fig. 9: Motion Manager view of the speed control

The speed controller uses the torque controller which has already been set and optimized as necessary. The variation of the control deviation over time is used to determine the torque required for the balancing of target values and actual values. The subsidiary torque controller provides the required torque if no limitations are active.

The parameters of the speed controller depend on the load which the motor has to drive:

- Mass inertia or the mass of the load that is moved
- Mass inertia of the motor
- Stiffness of the coupling between the motor and the driven load

## Configuring and starting the drive

### 4.3.4.1 Configuration

#### Speed controller

The speed controller is implemented within the Motion Controller as a PI controller. The parameters are the controller reset time  $T_{N,n}$  in the object 0x2344.02 and the controller gain  $K_{P,n}$  in the object 0x2344.01.

Tab. 13: Velocity control parameter set

Index	Subindex	Name	Type	Attr.	Default value	Meaning
0x2344	0x00	Number of Entries	U8	ro	6	Number of object entries
	0x01	Gain $K_p$	U32	rw	a)	Controller gain [As $1e^{-6}$ ]
	0x02	Integral Time TN	U16	rw	a)	Controller reset time [100 $\mu$ s]
	0x03	Velocity Deviation Threshold	U16	rw	65535	Maximum permissible control deviation
	0x04	Velocity Deviation Time	U16	rw	100	Maximal permissible duration of a control deviation outside the corridor
	0x05	Velocity Warning Threshold	U32	rw	30000	Warning threshold for the speed in user-defined units, see 0x2324.01 bit 21
	0x06	Integral part option	U8	rw	0	Configuration of the speed control loop: 0: Integral component active 1: Stopped integral component in the position window (in PP mode) 2: Integral component deactivated

a) Motor-specific, is set by the motor selection wizard.

**i** If a FAULHABER motor is selected in the Motion Manager motor selection wizard, the pre-set controller settings for no-load operation are loaded.

The controller configuration wizard also permits the controller to be adapted to a moving load.

#### Set-points

- In operating modes CSV and PV the set-points for the speed controller are input directly via the communications system (object 0x60FF). In operating mode AVC the set-point specification is set via a discrete source, such as an analog input (see chap. 4.9, p. 75 and chap. 4.7, p. 57).
- In operating modes with an active position controller, the target velocity is determined by the position controller.

#### Actual values

The velocity actual value can be determined by different sensors (see chap. 4.7, p. 57). If Hall sensors or an encoder are used, the velocity actual value is determined internally. If the actual speed is determined via a freely configurable input (e.g., an analog input) the conversion of the input value into a velocity must be set up manually.

**i** If a drive system has not only a motor-mounted sensor but also a load-mounted sensor (e.g., an incremental encoder) on the gearhead output, the velocity actual value must be determined using the motor-mounted sensor. Control of the position can be based on the additional load-mounted sensor.



## Configuring and starting the drive

### Limits

The target velocities in the controller are limited by the maximum motor speed set in the object 0x6080. In addition, the set-points in operating modes with active profile generator are limited to a maximum profile speed (see chap. 4.4, p. 43).

Tab. 14: Maximum motor speed

Index	Subindex	Name	Type	Attr.	Default value	Meaning
0x6080	0x00	Maximum Motor Speed	U32	rw	32767	Maximum speed of the motor in user-defined units

### Optimization of the control

The Motion Manager control configuration wizard allows the parameters of the controller to be adapted to the control task. In order to achieve this, either the inertia factor  $K_j$  can be entered manually or the parameters for the range can be determined via an identification procedure.

$$K_j = \frac{J_M + J_L}{J_M}$$

The stated inertia factor  $K_j$  allows the Motion Manager to determine controller gain and the filter time for the velocity actual value. A rigid coupling to the load is assumed. If elasticity or play is present (e.g., if a drive belt or a gearhead is used) the controller gain (0x2341.01) must be reduced, if necessary.

**i** Dynamically configured controllers can be set up to an inertia factor of about 4. If the inertia factor  $K_j > 4$ , a highly dynamic controller is affected by the setting limits.

If the standard controller parameters are used for inertia factors  $K_j > 10$  the drive will be noticeably noisier, since even minor displacements of the actual velocity value will lead to a significant control intervention.



### CAUTION!

#### Hazards due to hot surfaces.

Because of the higher demands on the controller at inertia factors  $K_j > 10$  the heat generated by the drive will increase.

- ▶ Ensure that the drive is adequately cooled.
- ▶ Do not touch the drive without protective clothing.

**i** At inertia factors  $K_j > 10$  it is possible that the rated torque of the drive can no longer be achieved. Due to the rise in temperature, the thermal protection mechanisms come into effect (see chap. 6, p. 152).

For a very smooth running of the motor, especially with higher inertia factor  $K_j$ , the time constant of the actual value filter (0x2345.01) may have to be increased. The controller reset time (0x2344.02) must be increased proportionately and, if necessary, the controller gain (0x2344.01) reduced.

The Motion Manager commissioning wizard has already preset the speed controller. The controller tuning tool is available in the Motion Manager for optimization of the controller parameters for a dynamic operation.

**i** For manual optimization of the speed controller, apply set-point jumps to the controller and adjust the controller gain (see Fig. 10 or Fig. 11).

## Configuring and starting the drive

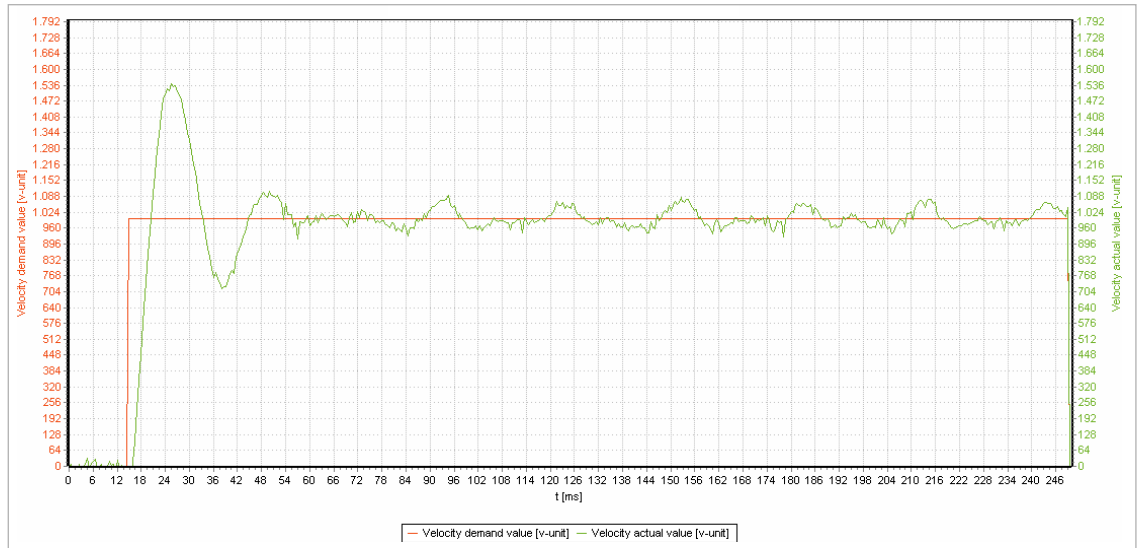

Fig. 10: Set-point jump during speed control

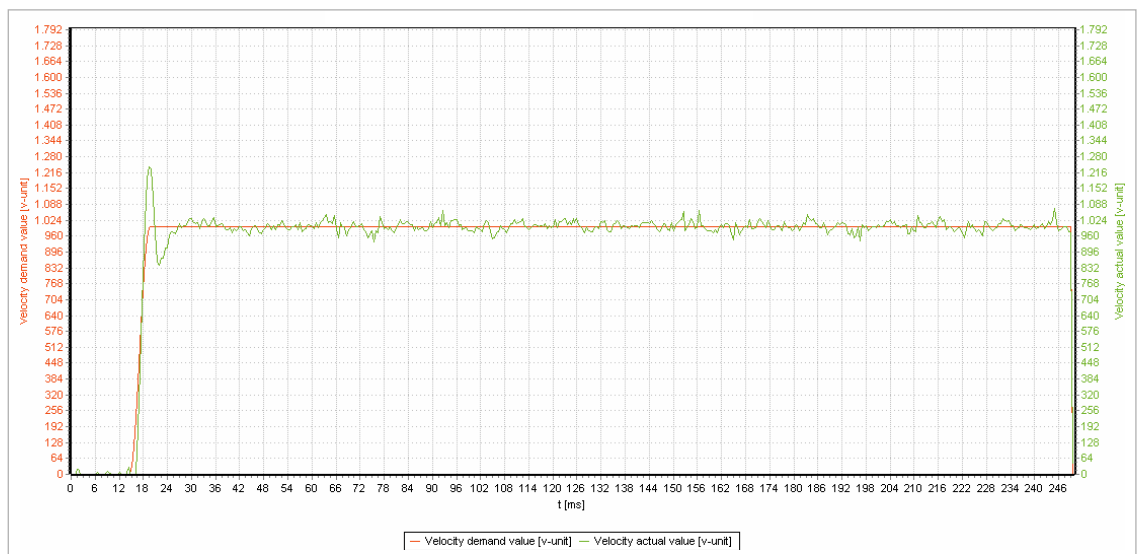

Fig. 11: Set-point jump during optimized speed control

## Configuring and starting the drive

### 4.3.4.2 Filter settings

#### Actual value filter (0x2345)

The speed controller uses a configurable actual value filter for the actual speed. The filter time can be adjusted to the application:

- If the quality and resolution of the sensor system is high, the filter time can be reduced.
- If only a rough resolution of the speed information is available (for instance when using digital Hall sensors or incremental sensors of low resolution), the filter time must be increased.
- The filter time should be increased if large masses or high moments of inertia have to be controlled, since otherwise small changes in the actual speed of the motor can lead to large control variations at the motor.

 The wizards of the Motion Manager set the filter time appropriately.

Tab. 15: Velocity filter parameter set

Index	Subindex	Name	Type	Attr.	Default value	Meaning
0x2345	0x00	Number of Entries	U8	ro	2	Number of object entries
	0x01	Actual Velocity Filter $T_F$	U16	rw	a)	Filter time $T_F$ [100 $\mu$ s]
	0x02	Display Velocity Filter	U16	rw	20	Filter time for displaying the actual speed [100 $\mu$ s]

a) Motor-specific, is set by the motor selection wizard.

#### Set-point filter (0x2346)

The set-point filter damps abrupt changes of the speed set-point. This reduces the overshoot of the speed controller. To do this, set the filter time of the set-point filter to a value identical to the reset time of the speed controller.

Use of the set-point filter is only recommended in the APC and AVC operating modes when using stepped set-point specifications.

Tab. 16: Set-Point Velocity filter parameter set

Index	Subindex	Name	Type	Attr.	Default value	Meaning
0x2346	0x00	Number of Entries	U8	ro	2	Number of object entries
	0x01	Setpoint Velocity Filter $T_F$	U16	rw	a)	Filter time $T_F$ [100 $\mu$ s]
	0x02	Setpoint Filter Enable	U8	rw	0	0: inactive 1: Active

a) Motor-specific, is set by the motor selection wizard.

## Configuring and starting the drive

### 4.3.4.3 Monitoring

Four monitors for the speed are active in the speed controller. These monitor whether the drive is stationary ( $n=0$ ) and whether in profile velocity mode the drive has reached the target speed.

Tab. 17: Monitoring for the speed

Name	Description	Parameter
Velocity threshold	Monitors whether the drive is at a standstill	0x606F, 0x6070
Velocity window	Monitors whether the drive has reached the target speed	0x606D, 0x606E
Velocity deviation window	Monitors whether an adjustable speed deviation was exceeded	0x2344.03, 0x2344.04
Velocity warning threshold	Monitors whether an adjustable limit speed was exceeded	0x2344.05

The parameters set for monitoring are the speed corridor and the minimum residence time in the corridor.

#### Velocity Window (0x606D)

Index	Subindex	Name	Type	Attr.	Default value	Meaning
0x606D	0x00	Velocity Window	U16	rw	32	Corridor around the set speed in user-defined units

#### Velocity Window Time(0x606E)

Index	Subindex	Name	Type	Attr.	Default value	Meaning
0x606E	0x00	Velocity Window Time	U16	rw	48	Minimum residence time within the corridor in ms

#### Velocity Threshold (0x606F)

Index	Subindex	Name	Type	Attr.	Default value	Meaning
0x606F	0x00	Velocity Threshold	U16	rw	32	Corridor at $n = 0$ in user-defined units

#### Velocity Threshold Time (0x6070)

Index	Subindex	Name	Type	Attr.	Default value	Meaning
0x6070	0x00	Velocity Threshold Time	U16	rw	48	Monitoring time [ms]. If the speed lies outside the corridor for longer than is listed here, the speed is reported as not equal to 0.

## Configuring and starting the drive

In addition to these standard monitors the control deviation of the speed loop is assessed using the settings in objects 0x2344.03 and 0x2344.04.

Index	Subindex	Name	Type	Attr.	Default value	Meaning
0x2344	0x00	Number of Entries	U8	ro	6	Number of object entries
	0x01	Gain $K_p$	U32	rw	a)	Controller gain [ $As \cdot 1e^{-6}$ ]
	0x02	Integral Time TN	U16	rw	a)	Controller reset time [100 $\mu s$ ]
	0x03	Velocity Deviation Threshold	U16	rw	65535	Maximum permissible control deviation
	0x04	Velocity Deviation Time	U16	rw	100	Maximal permissible duration of a control deviation outside the corridor
	0x05	Velocity Warning Threshold	U32	rw	30000	Warning threshold for the speed in user-defined units, see 0x2324.01 bit 21
	0x06	Integral part option	U8	rw	0	Configuration of the speed control loop: 0: Integral component active 1: Stopped integral component in the position window (in PP mode) 2: Integral component deactivated

a) *Motor-specific, is set by the motor selection wizard.*

## Configuring and starting the drive

### 4.3.5 Position controller

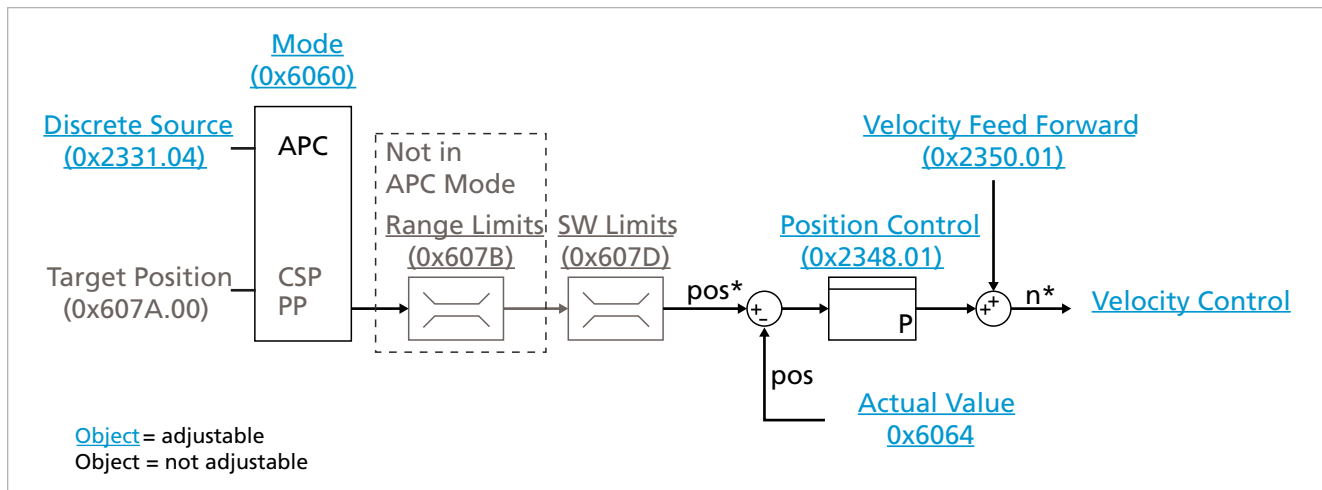

Fig. 12: Motion Manager view of the position control

The position controller represents the outermost control loop in the Motion Controller. The remaining distance of the movement, from which the speed is derived, is calculated from the comparison of the position set-points and actual values.

#### 4.3.5.1 Configuration

The position controller is implemented as a P-controller. Object 0x2348 has only the parameter controller gain  $K_v$ .

##### Position Control Parameter Set (0x2348)

Index	Subindex	Name	Type	Attr.	Default value	Meaning
0x2348	0x00	Number of Entries	U8	ro	1	Number of object entries
	0x01	Gain $K_v$	U8	rw	a)	Controller gain [1/s], range: 1–255

a) Motor-specific, is set by the motor selection wizard.

**i** If a FAULHABER motor is selected in the Motion Manager motor selection wizard, the pre-set controller settings for no-load operation are loaded.

The controller configuration wizard also permits the controller to be adapted to a moving load.

#### 4.3.5.2 Set-points

In the Profile Position (PP) operating mode and Cyclic Synchronous Position (CSP) operating mode the set-points can be specified using the object 0x607A.00 of the communications system.

In the Analog Position Control (APC) operating mode the target position is determined directly via a discrete source (see chap. 4.9, p. 75 and chap. 4.7, p. 57).

## Configuring and starting the drive

### 4.3.5.3 Actual values

The position actual value can be determined using different sensor systems (see chap. 4.7, p. 57). The following sensor systems are often employed:

- Analog Hall signals for BL motors and linear BL servomotors
- Incremental encoders or protocol-based absolute encoders (AES or SSI) for BL motors
- Incremental encoders for DC motors
- Analog voltages, e.g., via a position potentiometer

**i** Internally the position is calculated in increments directly in the resolution of the position encoder that is used. For analog Hall signals the position resolution is 4096 increments per revolution of the shaft.

The Factor Group (see chap. 4.8, p. 65) allows the internal representation to be converted into application-specific physical scaling, such as into ° or mm.

#### Limits

The position set-point in object 0x607A is limited in advance by the Position Range Limits and the Software Position Limits.

Position Range Limits limit the value range for the position actual value and position set-point. Values outside the defined range are wrapped to the opposite end of the value range.

#### Example

The Position Range Limits are set as follows:

- Negative limit (0x607B.01) = -2048
- Positive limit (0x607B.02) = 2047

During positive movement in velocity mode the actual position first reaches the value 2047 and in the next step wraps to the position -2048.

Thus no absolute set-points that are outside the defined range can be specified. Relative set-points can also be specified in the PP operating mode. Thus any desired positioning in a direction can be achieved.

For instance a belt may be driven by a shaft to achieve a direction of conveying. For this the shaft is rotated by one revolution each. In the Profile Position (PP) operating mode the set-point specification for this is specified relative to one revolution each.

Software Position Limits set limits to the range of positions. No set-points are accepted outside of this range. Software Position Limits can also not be violated with relative positioning.

## Configuring and starting the drive

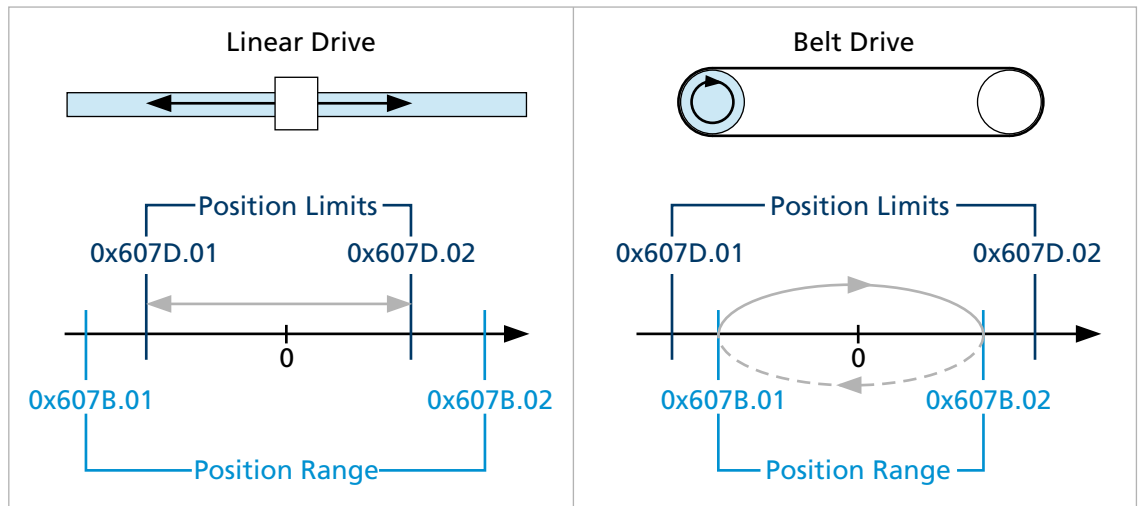

Fig. 13: Software Position Limits and Position Range Limits for linear drive system and belt drive system

### Optimization of the control

The dynamics of position control depend on the dynamics of the subordinate velocity control loop. High gains in the position controller are generally available only if the subordinate controllers are tuned to fast reaction.

The Motion Manager commissioning wizard has already preset the position controller.

The controller tuning tool is available in the Motion Manager for further optimization of the controller parameters.

For optimization of the position controller, apply set-point jumps to the position controller and adjust the controller gain (see Fig. 14 or Fig. 15).

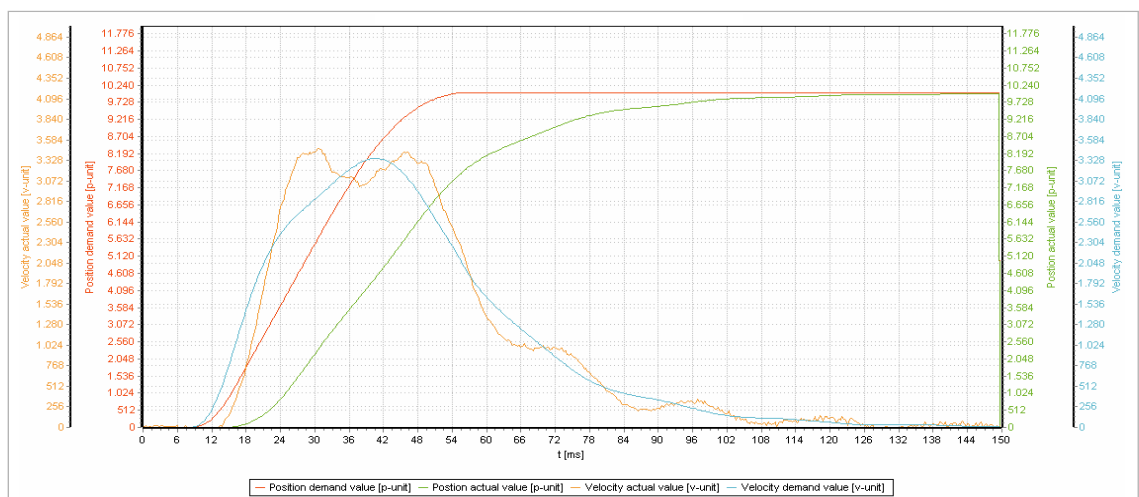

Fig. 14: Set-point jump for position control



## Configuring and starting the drive

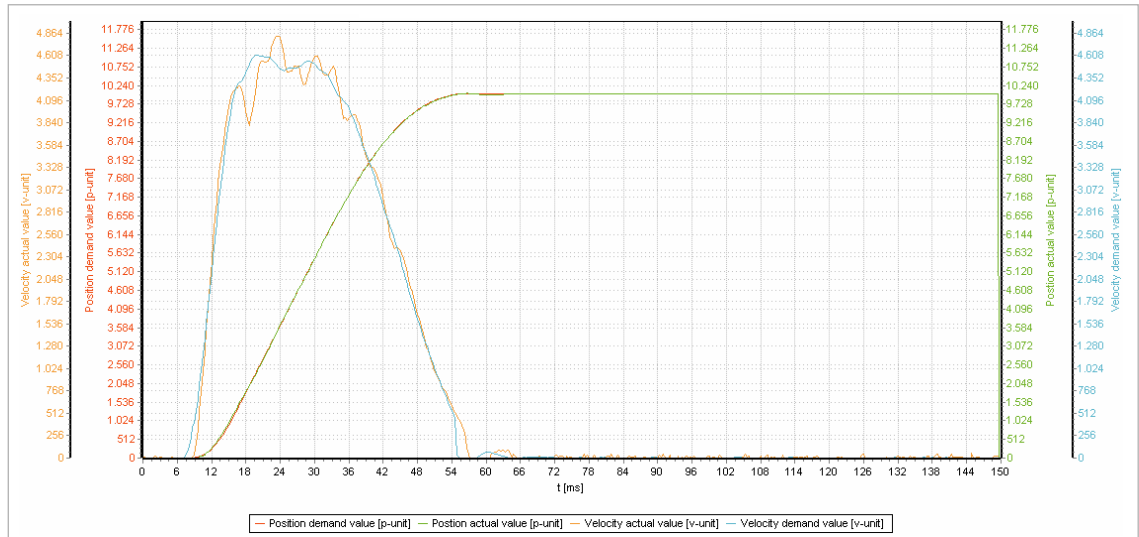

Fig. 15: Set-point jump for optimized position control

### Gain Scheduling

The behavior of the speed controller within the target corridor for the position can be modified appropriately via the Gain Scheduling (0x2347) parameter of the speed controller.

$K_{rel}$  defines a factor by which the gain of the speed controller within the position corridor is increased or decreased. The factor is effective in proportion to the position deviation.

The controller gain of the speed controller can be adjusted by this means by a maximum of  $\pm 100\%$ .

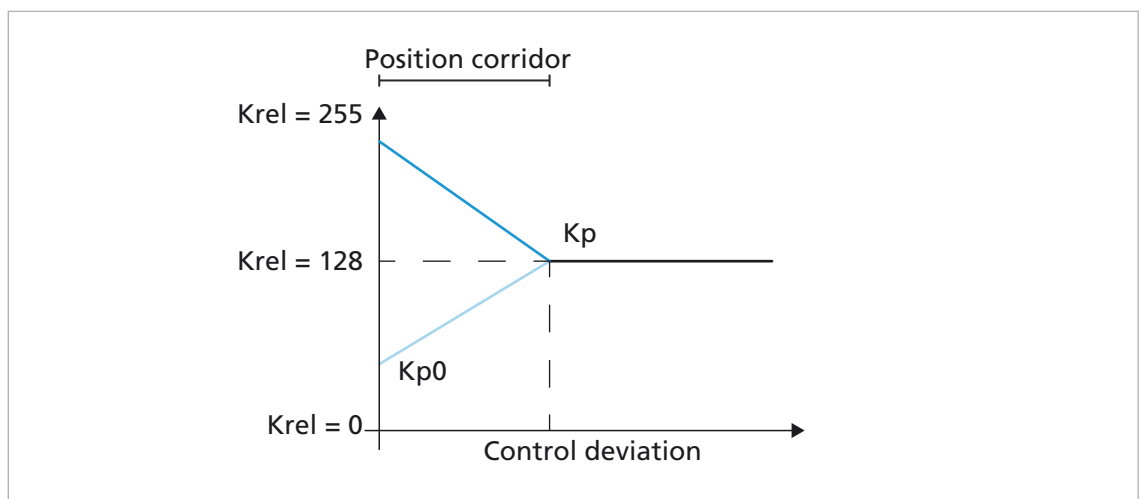

Fig. 16: Adaptive gain of the speed controller

- Values of  $K_{rel} < 128$  lead to a reduced gain for the speed control within the position corridor.
- For  $K_{rel} = 0$ , the gain in the corridor is reduced to 0.
- For  $K_{rel} = 128$ , the gain in the corridor remains unchanged.
- For  $K_{rel} > 128$ , the gain of the speed control in the corridor is increased, up to factor 2 at  $K_{rel} = 255$ .

## Configuring and starting the drive

### Gain scheduling (0x2347)

Index	Subindex	Name	Type	Attr.	Default value	Meaning
0x2347	0x00	Number of Entries	U8	ro	2	Number of object entries
	0x01	Gain Factor $K_p$	U8	rw	128	Gain factor (used by the speed control in PP mode on the $K_p$ ) 0: Reduction of the gain to 0 in the target 128: No variable gain 255: Doubling the gain in the target
	0x02	Gain Factor $K_v$	U8	rw	128	Gain factor (applied to $K_v$ in PP mode) 0: Reduction of the gain to 0 in the target 128: No variable gain 255: Doubling the gain in the target

#### Example

The speed controller is to be configured to a smoother setting within the position corridor, so as to maintain the target position as smoothly as possible. For this purpose, the target corridor is specified via the object Position Window (0x6067) in increments or user-specific units. The factor for the maximum degree to which the gain of the speed controller can be reduced is specified by the object 0x2347.01.

#### Speed set-point filter

If stepped set-point specifications are applied to the controller in APC mode, the positioning can be optimized through the use of the speed set-point filter (0x2346). The filter time of the speed set-point filter primarily determines the amount of position overshoot beyond the specified target position.

#### Other settings

Two control monitoring functions supervise the position controller. In Profile Position mode the question of whether the drive has reached the target position is monitored. In addition the controller deviation of the position controller is monitored as a following error.

Tab. 18: Monitoring for the controller

Name	Description	Parameter
Position Window	Monitors whether the drive has reached the target position	0x6067, 0x6068
Following Error Window	Monitors whether the set following error was exited	0x6065, 0x6066

The position corridor and the minimum residence time in the corridor are set as parameters for monitoring the actual position. In Profile Position mode the position is signaled as reached when the actual position has remained within the target corridor for at least the position window time.

### Position Window (0x6067)

Index	Subindex	Name	Type	Attr.	Default value	Meaning
0x6067	0x00	Position Window	U32	rw	32	Corridor around the target position in user-defined units

### Position Window Time (0x6068)

Index	Subindex	Name	Type	Attr.	Default value	Meaning
0x6068	0x00	Position Window Time	U16	rw	48	Minimum residence time within the corridor in PP operating mode, until the target position is reported as achieved.

## Configuring and starting the drive

### Following Error window (0x6065)

Index	Subindex	Name	Type	Attr.	Default value	Meaning
0x6065	0x00	FollowingError Window	U32	rw	32	Corridor for the control deviation of the position controller in user-defined units

### FollowingError time out (0x6066)

Index	Subindex	Name	Type	Attr.	Default value	Meaning
0x6066	0x00	FollowingError Time Out	U16	rw	48	Minimum time for which a following error must lie outside the defined corridor before the error is reported

## 4.4 Configuration of the profile generator

**i** The function of the profile generator is only available in the PP and PV operating modes. In operating modes CSP, CSV and CST the set-points are directly applied to the control.

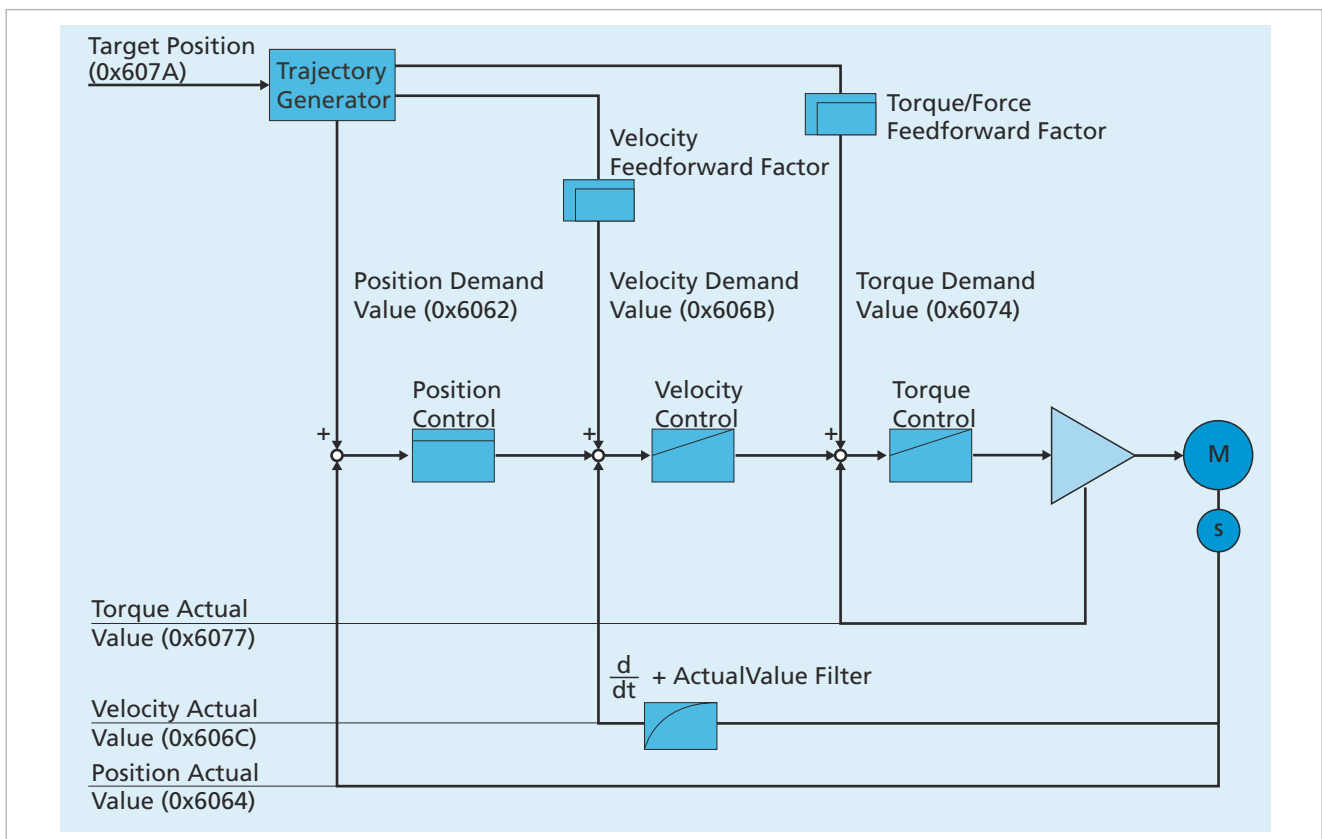

Fig. 17: Control loop with upstream profile generator

In the Profile Position mode (PP) and Profile Velocity mode (PV) operating modes, the profile generator calculates from the following values a speed profile for the position  $\text{Pos}(t)$ , speed  $v(t)$  and acceleration  $a(t)$ .

## Configuring and starting the drive

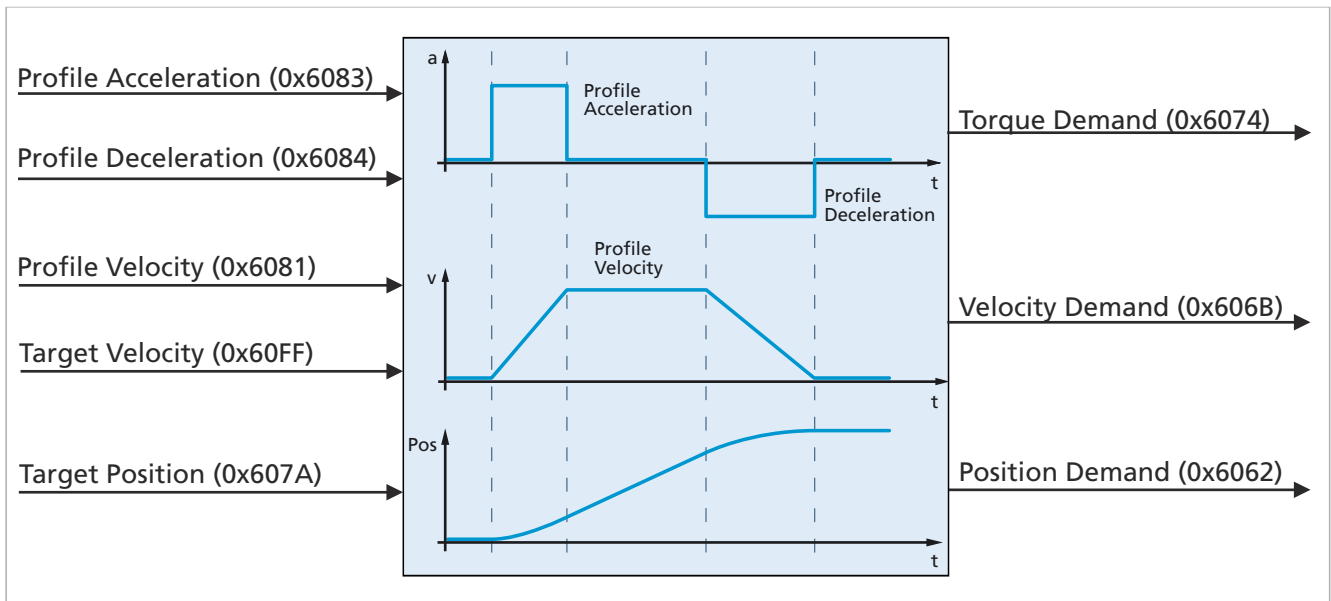

Fig. 18: Calculation of the speed profile

The profile type can be selected using the object 0x6086.

The following are supported:

- Linear profiles: Accelerations are directly activated. The movements correspond to a trapezoidal profile for the speed. This type of profile is limited in relation to the activated acceleration and unlimited in relation to the resulting jerk.
- Sin<sup>2</sup> speed: The accelerations are activated so that sin<sup>2</sup> speed profiles result. This type of profile is limited both in relation to the activated acceleration and also in relation to the resulting jerk.

**i** Linear profiles are suitable for stiff mechanisms. Linear profiles are the quickest way to achieve the target position or the target speed. Sin<sup>2</sup> profiles are suitable for elastically coupled mechanisms. In theory, the target position is achieved later. Since Sin<sup>2</sup> profiles generate less oscillation, the setting time can nevertheless be lower than when using linear profiles.

The set-points for the control are always specified via the profile generator in the PP and PV operating modes. The additional pre-control values can be applied to the control. The pre-control values for speed and torque or force can be fully or only partly activated by a parameter. In addition the pre-control values can be delayed by means of a filter.

Tab. 19: Set-point specification for PP or PV

Operating mode	Target position	Target speed	Target torque
PP	From the profile generator	Can be activated as a pre-control value	Can be activated as a pre-control value
PV	-	From the profile generator	Can be activated as a pre-control value

## Configuring and starting the drive

### Velocity Feedforward Parameters (0x234A)

Index	Subindex	Name	Type	Attr.	Default value	Meaning
0x234A	0x00	Number of Entries	U8	ro	2	Number of object entries
	0x01	Velocity Feedforward Factor	U8	rw	0	Factor for the torque or force control 0: 0% feedforward control 128: 100% feedforward control
	0x02	Velocity FeedForward Delay	U16	rw	0	Set-point delay: 0: Undelayed activation 1: Activation delayed by one sampling

### Torque/Force Feedforward Parameters (0x2349)

Index	Subindex	Name	Type	Attr.	Default value	Meaning
0x2349	0x00	Number of Entries	U8	ro	2	Number of object entries
	0x01	Current FeedForward Factor	U8	rw	0	Factor for the torque or force control 0: 0% activation of the feedforward control 128: 100% feedforward control
	0x02	Current FeedForward Delay	U16	rw	0	Set-point delay: 0: Undelayed activation 1: Activation delayed by one sampling

## Configuring and starting the drive

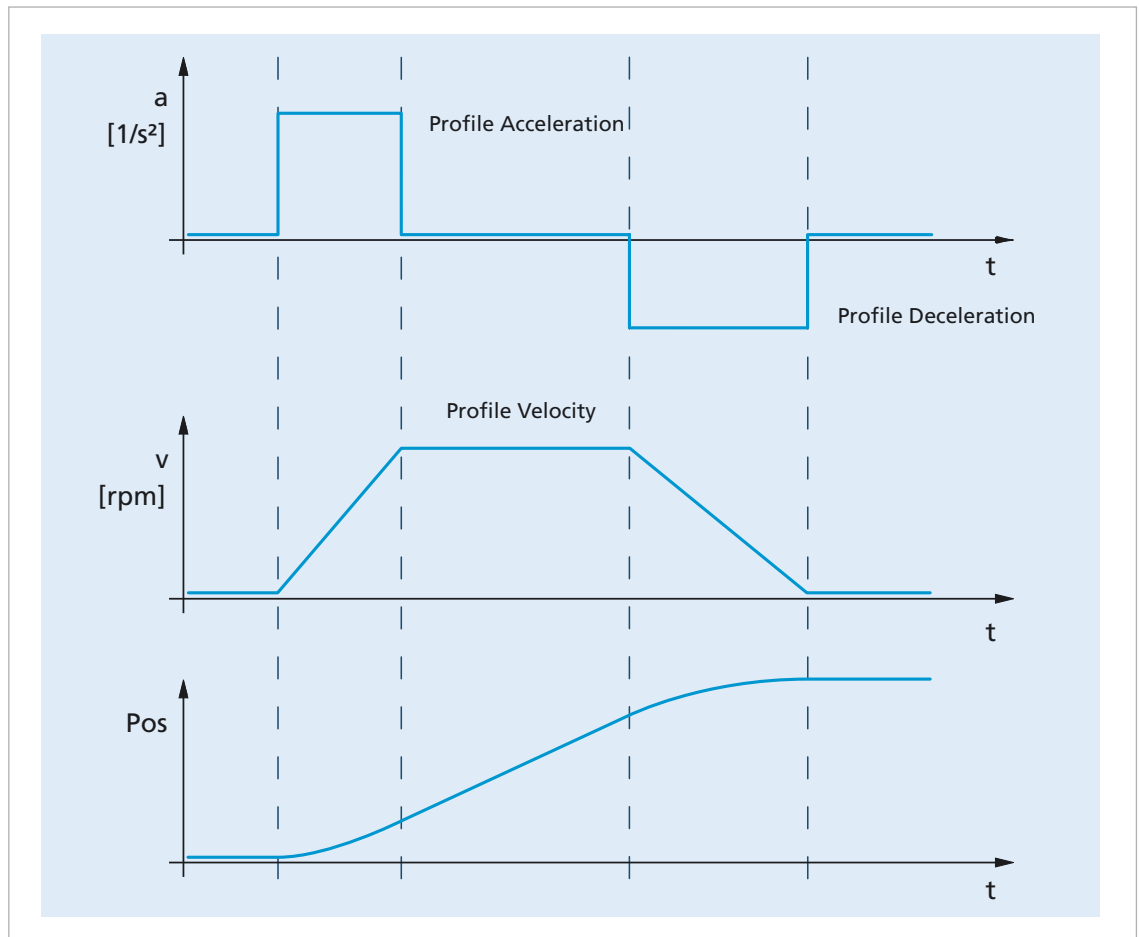

Fig. 19: Target position and speed values when using linear profiles

**i** In order to use the profile planning, the required profile parameters for the drive must be physically capable of being implemented.

Typical acceleration values for DC and BLDC servomotors are up to  $7500 \text{ 1/s}^2$ . Linear motors even reach accelerations of up to  $30000 \text{ 1/s}^2$  and more.

**i** Information on the use of the profile generator with a sequence of set-points is provided in the description of the Profile Position operating mode (PP) (see chap. 5.2.4, p. 100).

**i** The Motion Manager adjusts to profile parameters that are matched to the motor and load via the commissioning wizards.

## Configuring and starting the drive

### 4.5 Voltage output

Object 0x2340.01 allows the type of voltage output to be specified. The setting variants for the voltage output are as follows:

- 0: Not active
- 1: DC motor
- 2: BL motor with block commutation
- 3: BL or linear motor with sine commutation

The further sub-indices of the object 0x2340 allow the voltages at the motor to be read back. The scaling is 10 mV per digit.



The selection of the motor variant is available only in the *Switch On Disabled* state.

BL motors with block commutation are supported only for BL motors with digital Hall signals.

Tab. 20: Combinations of motor types and encoders for various controllers

Motor	DC	Block commutation	Sine commutation
DC	Encoder <sup>a)</sup>	–	–
BL	–	Digital Hall signals <sup>b)</sup>	Digital Hall signals + encoder or Analog Hall signals or AES or SSI absolute encoder

a) DC motors are not electronically commutated.

b) Block commutation requires at least digital Hall sensors for commutation. Speed and position should be ascertained via an additional incremental encoder.

## Configuring and starting the drive

### General Parameters (0x2340)

Index	Subindex	Name	Type	Attr.	Default value	Meaning
0x2340	0x00	Number of Entries	U8	ro	8	Number of object entries
	0x01	Commutation Type	U8	rw	3	Commutation type 0: Switched off 1: DC motor 2: BL motor with block commutation 3: BL motor with sine commutation
	0x02	Motor Output Voltage DC	S16	rw	-	Motor output voltage DC <sup>a)</sup>
	0x03	Motor Output Voltage BL Block	S16	rw	-	Motor output voltage, BL block <sup>a)</sup>
	0x04	Motor Output Voltage $X_d$	S16	rw	-	Motor output voltage $X_d$ <sup>a)</sup>
	0x05	Motor Output Voltage $X_q$	S16	rw	-	Motor output voltage $X_q$ <sup>a)</sup>
	0x06	Sinus Output Voltage $U_a$	U16	ro	-	Phase voltage $U_a$ <sup>a)</sup>
	0x07	Sinus Output Voltage $U_b$	U16	ro	-	Phase voltage $U_b$ <sup>a)</sup>
	0x08	Sinus Output Voltage $U_c$	U16	ro	-	Phase voltage $U_c$ <sup>a)</sup>

a) All voltages are in multiples of 10 mV



If a motor is selected in the Motion Manager motor selection wizard, the commutation type is already set to match the motor type.



## Configuring and starting the drive

### 4.6 Setting the sensor inputs

The following functions of the sensor connections are supported:

- Sensor connection:
  - Connection of three analog Hall sensors as motor position sensors for position and speed control and also for commutation
  - Connection of three digital Hall sensors as motor position sensors for speed control and for commutation
  - Connection of two analog Hall sensors (sin/cos) as motor position sensors for position and speed control and also for commutation
- Encoder connection:
  - Connection of an incremental encoder with two or three channels
  - Connection of a 12-bit AES encoder (single-turn)
  - Connection of a BiSS-C encoder with max. 30-bit resolution (single-turn/multi-turn)
  - Connection of an SSI encoder with max. 30-bit resolution (single-turn/multi-turn)

As actual value of the position and speed of the controlled motor or as set-point for position and speed.
- Analog inputs (AnIn1/AnIn2):
  - Connection of analog sources with a voltage range of  $\pm 10$  V as set-points for position, speed or torque
  - Connection of analog sources with a voltage range of  $\pm 10$  V as actual values for position or speed
- PWM input (DigIn1 or DigIn2):
  - Connection of a PWM signal as a set-point for position, speed or torque
  - Connection of a PWM signal as an actual value for position or speed
- Additional encoders (DigIn1-DigIn3)
  - Connection of an incremental encoder with two or three channels.
  - Connection of a pulse/direction signal at DigIn1 and DigIn2 as a set-point or actual value for the position of the drive.

**i** The sensors are already incorporated in Motion Controllers of the MCS product range. Motion Controllers of the MCS product range therefore haven no sensor connections.

Tab. 21: Special functions of the digital inputs

	2-channel encoder	3-channel encoder	Set-point Step/Dir	Set-point Quadrature	Touch probe	PWM
DigIn1	A	A	Step	A	–	Ch1
DigIn2	B	B	DIR	B	TP1	Ch2
DigIn3	–	Index	–	–	TP2	–
DigIn4...8	–	–	–	–	–	–

## Configuring and starting the drive

### 4.6.1 Configuring the motor encoder

Either an incremental encoder or a protocol-based AES or SSI encoder can be connected at the encoder connection. The encoders can be connected with or without differential signals. For details on the supported encoder types, see Product Application Note 158. The motor encoder is configured using object 0x2315.

Tab. 22: Motor encoder settings

Index	Subindex	Name	Type	Attr.	Default value	Meaning
0x2315	0x00	Number of Entries	U8	ro	9	Number of object entries
	0x01	Operation Mode	U16	rw	0	Selection of the encoder type
	0x02	IE Resolution	U32	rw	0x0800	Resolution as incremental encoder
	0x03	Motor Encoder Position (unscaled)	S32	ro		Actual value of the position without conversion
	0x04	Gain	S32	ro	0x40004000	Scaling as fraction numerator/denominator
	0x05	Motor Encoder Position (scaled)	S32	rw		Position after conversion
	0x06	Absolute Encoder Bits	U32	rw	0x000C	Resolution of the absolute encoder, specified as preceding, multiturn and singleturn bits
	0x07	Encoder Status	U8	ro	0	Status bits and CRC of a BiSS-C-based encoder

Tab. 23: Configuration of the encoder type in object 0x2315.01

Bit	Meaning
0	Incremental encoder connected (single-ended or differential)
1	Index signal present
2	Index signal evaluation at the rising edge
3–7	Reserved
8	Absolute encoder with BiSS-C interface connected (single-ended or differential)
9	SSI encoder connected (single-ended or differential)
10	Position is in Gray code
11	Reserved
12	Multiturn encoder
13–15	Reserved

#### Example: Configuring a 3-channel incremental encoder with positive index pulse

- ▶ In the object 0x2315.01, set the value **0x00 07**.
  - ✎ The 3-channel incremental encoder with positive index pulse is now set.

#### Example: Configuring a 12-Bit AES encoder

- ▶ In the object 0x2315.01, set the value **0x01 00**.
  - ✎ The 12-bit AES encoder is now set.

## Configuring and starting the drive

### Example: Configuring an incremental encoder with 512 lines per revolution

**i** For incremental encoders the encoder resolution in increments per revolution must be stated explicitly. By means of the quadrature signal, the resolution is 4 times the line count of the encoder.

- ▶ Calculate the resolution of the incremental encoder as a quadrature signal:
  - Resolution of the encoder =  $4 \times 512 = 2048$
- ▶ In the object 0x2315.01, set the encoder type to the value **0x00 07**.
- ▶ In the object 0x2315.02, set the encoder resolution to the value **2048**.
  - ↪ The incremental encoder is now set with 512 lines per revolution.

### Example: Multi-turn BiSS-C absolute encoder with 12-bit revolution counter and 13-bit resolution per revolution

- The motor is connected to the Motion Controller and selected via the motor selection wizard.
- AES was first selected as encoder.
- ▶ In Encoder type in 0x2315.01, select:
  - Bit 8 (BiSS-C)
  - Bit 12 (multiturn)
- ▶ In object 0x2315.06, set the encoder resolution **0x0C0D**.
- ▶ Save configuration.
- ▶ Reset the controller to apply the new settings.

**i** After making changes to the resolution of the position encoder, the standard setting of the factor group should be checked.

In general, the feed in object 0x6092.01 should correspond to the resolution of the encoder in one revolution.

## Configuring and starting the drive

### 4.6.2 Configuring an additional encoder

Either an incremental encoder with or without an index signal or a pulse/direction signal can be connected at the digital outputs. The trigger thresholds set for the digital input in the object 0x2310.08 are effective. The additional encoder is now configured by the entries in the object 0x2316.

Tab. 24: Reference encoder settings

Index	Subindex	Name	Type	Attr.	Default value	Meaning
0x2316	0x00	Number of Entries	U8	ro	5	Number of object entries
	0x01	Operation Mode	U16	rw	0	Selection of the encoder type
	0x02	IE Resolution	U32	rw	2048	Resolution as incremental encoder
	0x03	Reference Encoder Position (unscaled)	S32	ro	0	Actual value of the position without conversion
	0x04	Gain	S32	rw	0x40004000	Scaling as fraction numerator/denominator
	0x05	Reference Encoder Position (scaled)	S32	rw	0	Position after conversion.

 The object 0x2316.04 allows the number of steps on the reference encoder to be converted into scaling suitable for the internal position resolution.

Tab. 25: Available selection of the encoder types in the object 0x2316.01

Bit	Meaning
0	Incremental encoders
1	Index signal present
2	Index signal evaluation at the rising edge
3–7	Reserved
8	Position specification by the pulse/direction signal
9–15	Reserved

#### Example: Configuring a 3-channel incremental encoder with positive index pulse

► In the object 0x2316.01, set the value **0x00 07**.

 The 3-channel incremental encoder with positive index pulse is now set.

 If a reference encoder is connected to the digital inputs, the following assignment is applicable:

- DigIn 1: Encoder track A
- DigIn 2: Encoder track B
- DigIn 3: Encoder index

## Configuring and starting the drive

### Example: Position specification via pulse/direction signal

- ▶ In the object 0x2316.01, set the value **0x0100**.
  - ↪ Position specification is set by the pulse/direction signal.

**i** The following assignment is applicable to the position specification by the pulse/direction signal:

- DigIn 1: Pulse
- DigIn 2: Direction
  - 0: Negative direction of movement
  - 1: Positive direction of movement

### Example: Specifying a position set-point via an external reference encoder

A BL motor with analog Hall signals should perform one revolution for each revolution of the reference signal. The reference signal has a resolution of 16384 increments per revolution. Through the analog Hall signals, the internal position resolution is 4096 increments per motor revolution.

- ▶ Calculating the position set-point:
  - $\text{Internal set-point} = 4096 \times (\text{reference value} / 16384)$
- ▶ Set the scaling factor for the internal set-point:
  - In the object 0x2316.04, set the value **0x10 00 40 00**.
- ↪ The scaling of the target position of an external reference encoder is set to 1/4

**i** If the additional encoder is also to be used as the actual value for the speed, object 0x2316.02 must be used to specify the resolution of the encoder in increments per revolution.

Example: IE3-256:

- 256 lines per revolution
- 1024 increments per revolution for the resolution

## Configuring and starting the drive

### 4.6.3 Adjusting the Hall sensors

Motors with analog Hall sensors should be adjusted before setting the controller. This results in smoother motor operation and higher position accuracy. The adjustment only needs to be performed once.

**i** When the Motion Manager is used, the Hall sensors can be adjusted using the motor selection of the Motion Manager. Alternatively, the adjustment can also be performed by a higher-level control (see Example: Dynamic Hall sensor adjustment).

The selection of the sensor type and the compensation procedure are performed using the object 0x2318.

Index	Subindex	Name	Type	Attr.	Default value	Meaning
0x2318	0x00	Number of Entries	U8	ro	4	Number of object entries
	0x01	Hall Sensor Type	U8	rw	0	Bit-coded selection of the sensor type (see chap. 4.6.3, p. 54)
	0x02	Enable Adaption	U8	rw	0	0: Adjustment switched off 1: Adjustment active
	0x03	Adaption Threshold Speed	U32	rw	1000	Minimum speed in $[\text{min}^{-1}]$ , from which the Hall signals are adjusted.
	0x04	Digital Hall Settings of Non-Faulhaber Motors	8	rw	0	Bit 0: <ul style="list-style-type: none"> <li>0x00: Hall sequence A–C–B (FAULHABER)</li> <li>0x01: Hall sequence A–B–C</li> </ul> Bit 7: <ul style="list-style-type: none"> <li>0x00: Hall signals are evaluated directly</li> <li>0x80: Hall signals are inverted</li> </ul> See FAULHABER Product AppNote 155.

The Hall sensors can be adjusted either statically by a reference run of at least an electrical pole width or dynamically during operation.

**i** For motors with 2 pole pairs, perform a one-off adjustment of the sensor signals in both magnetic poles.

**i** For dynamic adjustment or the special adjustment of BX4 and BP4 motors, run the motor initially at a low constant speed, and then start the adjustment.

In addition to the one-time adjustment, the Hall signals can also be constantly updated to, e.g., compensate for fluctuations caused by temperature changes. In addition, object 0x2318.03 allows the setting of a minimum threshold for the speed. The Hall sensors are adjusted when the value of the speed is above the specified value.

- Set the sensor type and adjustment procedure in the object 0x2318.01:
  - Bit 0: Adjustment procedure
    - 0: Dynamic adjustment: The amplitudes of the Hall signals are progressively adjusted as the motor is running. This should not be used for linear motors.
    - 1: Static adjustment: The amplitudes of the Hall sensors are scaled only after

## Configuring and starting the drive

explicitly starting an adjustment run at a suitable level.

- Bit 1: Sensor type
  - 0: Three sensor signals offset by 120° are evaluated
  - 1: Two sensor signals offset by 90° are evaluated.
- 2-7: Reserved

2. Perform the adjustment (see following examples).

### 4.6.3.1 Example: Dynamic Hall sensor adjustment

The dynamic adjustment adjusts the Hall signals during operation.

✓ Sensor type and adjustment procedure are now set.

1. Run the motor at a constant low speed.
2. At the start of the adjustment, set a value > 0 in the object 0x2318.02.
3. Allow the motor to run for a few seconds.
4. At the end of the adjustment, set the value 0 in the object 0x2318.02.
5. Run the motor at a speed significantly higher than the limit speed set in 0x2318.03.
6. Allow the motor to run for a few seconds.

🔗 The adjustment is now complete. The motor can be stopped and the parameters saved.

### 4.6.3.2 Example: Static Hall sensor adjustment

Static adjustment is particularly suitable for motors that do not run continuously over long distances, such as linear BLDC servomotors.

✓ Sensor type and adjustment procedure are now set.

1. At the start of the adjustment, set a value > 0 in the object 0x2318.02.
2. Run the drive for the maximum available length.
3. At the end of the adjustment, set the value 0 in the object 0x2318.02.

 The adjustment will be successful if at least one complete magnetic period of the motor (e. g. the magnetic pole width of the linear BLDC servomotor) has been passed.

 For the shortest movement distance during the static adjustment of the Hall sensors, activate the adjustment before starting the motor.

## Configuring and starting the drive

### 4.6.4 Configuring the PWM input

DigIn1 or DigIn2 can be used to read in a PWM signal as a set-point or actual value for the control system. The settings of the digital inputs are performed in object 0x2317.

Tab. 26: PWM input

Index	Subindex	Name	Type	Attr.	Default value	Meaning
0x2317	0x00	Number of Entries	U8	ro	7	Number of object entries
	0x01	Digital Input Pin	U8	rw	0	PWM input: 1: DigIn1 = PWM input 2: DigIn2 = PWM input
	0x02	PWM Input Frequency	U32	ro		Frequency of the PWM signal
	0x03	Duty Cycle Raw Value	S16	ro		Duty cycle of the PWM signal (unscaled)
	0x04	Duty Cycle Gain (Numerator / Divisor)	U32	rw	0x7FFF8000	PWM in gain (numerator/denominator)
	0x05	Duty Cycle Offset	S16	rw	0	PWM in offset
	0x06	Duty Cycle Scaled Value	S32	ro		Scaled pulse width
	0x07	Resolution As Encoder	S16	rw	1000	Resolution of the encoder

**i** The raw value of the Duty Cycle can assume values from 0 = 0% to 32767 = 100%. The measured duty cycle can be converted into an internal variable using the parameters for gain and offset.

**i** For examples on the use of analog inputs as set-point value for the control, see chap. 4.7, p. 57.



## Configuring and starting the drive

### 4.7 Signal paths

#### 4.7.1 Selection of the actual values

The values for the motor position and the speed can be taken from different sources. In addition, for BLDC and LM motors the commutation angle can be taken from different sources.

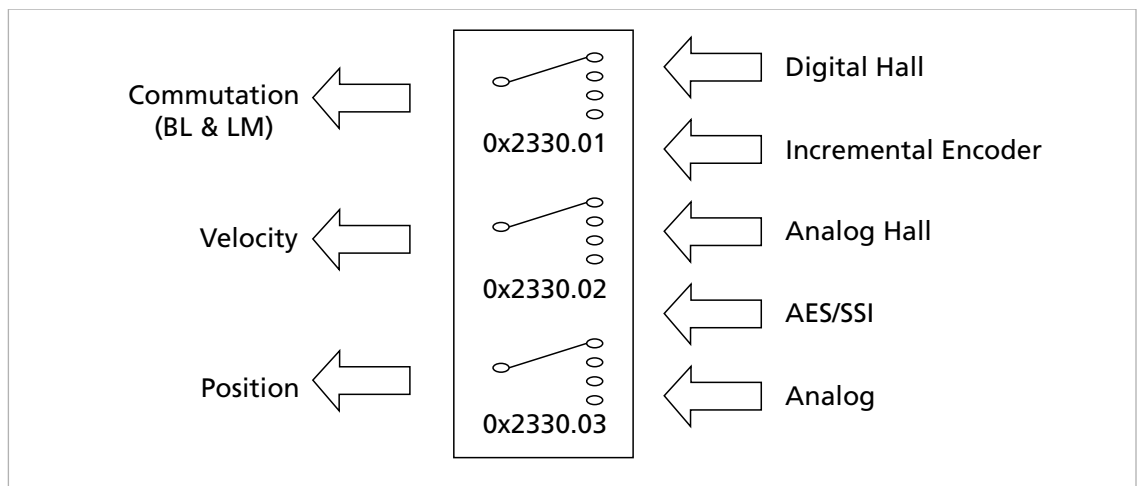

Fig. 20: Possible sources for selecting the actual values

If BL motors are used in combination with analog Hall sensors or AES encoders, the motor position, speed and commutation angle are reported by the same sensor.



Digital Hall sensors can be used for the commutation.

- When using digital Hall sensors, an additional incremental encoder is recommended for speed feedback.
- An incremental encoder is absolutely necessary for position control.

The commutation angle, speed and position can be measured by an encoder directly mounted on the motor. The position can be fed back by an encoder mounted on the load side, too.

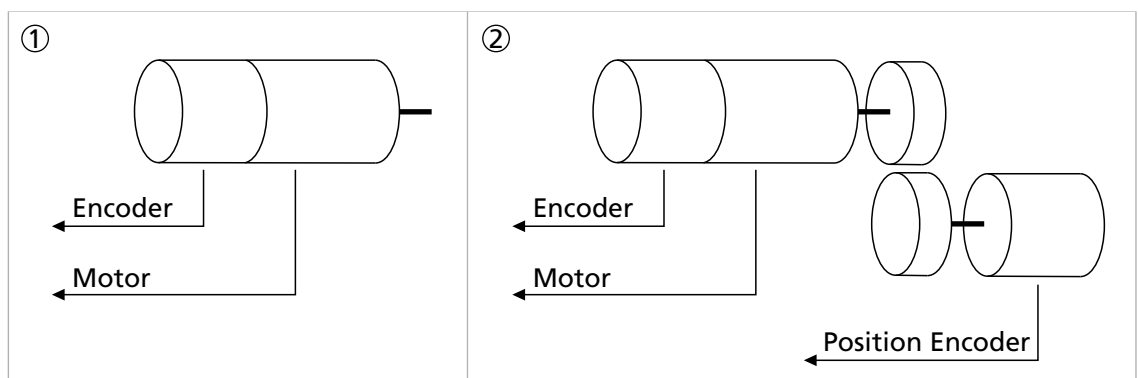

Fig. 21: Encoder use for position and speed recording

- 1 Single control loop for position and speed
- 2 Double control loop with separate encoders for speed and position

## Configuring and starting the drive

For DC motors, incremental encoders are generally used for position and speed feedback. The motor speed and position can be measured by an encoder directly mounted on the motor. As for BL motors, the position can optionally also be fed back by an encoder mounted on the load side.

**i** If the position encoder is mounted after a gearhead or gearing, the transmission ratio must be specified in object 0x2319. Otherwise, the relationship between motor speed and motor position can no longer be correctly calculated.

### Reduction Ratio, external position encoder

Index	Subindex	Name	Type	Attr.	Default value	Meaning
0x2319	0x00	Number of Entries	U8	ro	2	Number of object entries
	0x01	Numerator	U32	rw	1	Numerator of the reduction, e.g., 3696
	0x02	Divisor	U32	rw	1	Denominator of the reduction, e.g., 289

The selection of the sensor systems to be used is set by means of entries in the object 0x2330.

**i** If the motor and sensor system are configured using the Motion Manager motor selection wizard, all the settings will be correctly pre-set.

Tab. 27: Switch settings of the actual value switch in object 0x2330

Value	Commutation angle (0x2330.01) <sup>a)</sup>	Speed (0x2330.02)	Position (0x2330.03)
00			Not selected
01			Analog Hall sensors <sup>a)</sup>
02			Digital Hall sensors <sup>b)</sup>
03	Digital Hall sensors + motor encoders		Incremental encoder (encoder connection)
04			AES/SSI encoder (encoder connection)
05	Not supported		Incremental encoder (encoder connection)
06	Not supported		Additional encoder on I/O connection
07	Not supported		AnIn1 <sup>c)</sup>
08	Not supported		AnIn2 <sup>c)</sup>
09–12	Not supported		Reserved
13	Not supported		PwmIn <sup>c)</sup>

a) Only for BL motors and linear motors.

b) If digital Hall sensors are used without incremental encoders, the only commutation type available is block commutation.

c) Analog inputs and the PWM input must be converted into a suitable actual value by means of user-defined scaling.

## Configuring and starting the drive

Tab. 28: Configuration of the sensor systems

Position encoder	Object	Description
Digital Hall	0x2318	chap. 4.6.3, p. 54
Analog Hall	0x2318	chap. 4.6.3, p. 54
Motor encoder	0x2315	chap. 4.6.1, p. 50
Additional encoder	0x2316	chap. 4.6.2, p. 52
PWM	0x2317	chap. 4.6.4, p. 56
Analog input	0x2313	chap. 4.10, p. 83

### 4.7.1.1 Examples of the selection of actual values

**Set the AES encoder as the source for the commutation angle and actual value of the speed:**

- ▶ In the object 0x2330.01, set the value **04**.
- ▶ In the object 0x2330.02, set the value **04**.
- ↪ The AES encoder is set as the source for the commutation angle and actual value of the speed.

**Configuring a tacho sensor as the source for the actual speed:**

A tacho sensor is to be configured as the source for the actual speed. At  $5000 \text{ min}^{-1}$  the tacho sensor delivers a voltage of 10 V. With the standard setting, the 10 V voltage at AnIn is converted into a numeric value of 10,000.

-  The analog value must be converted into a numerical value suitable for the speed control. The internal scaling for analog speed set-points is  $n \text{ [min}^{-1}\text{]}$ .
- ✓ The tacho sensor is connected to AnIn1 or AnIn2.
- ▶ Calculate the scaling factor for the analog input:
  - The raw value of the analog input / internal numeric value for the voltage at 10 V =  $5000 / 10000 = 1/2$
- ▶ Set the scaling factor for the analog input in object 0x2313:
  - Depending on the analog input used, set the value **0x00 01 00 02** for the scaling factor 1/2 in the object 0x2313.01 or 0x2313.11
  - Ensure that depending on the analog input used, the value **0x00** is set for the offset in the object 0x2313.02 or 0x2313.12.
  - In the object 0x2330.02, configure the value **7 or 8** for the analog input used as the source for the actual speed.
- ↪ The tacho sensor is now set as the source for the actual speed.

## Configuring and starting the drive

### 4.7.2 Selection of discrete set-points

In the ATC, AVC, APC operating modes and in Voltage mode, a discrete source such as an analog input can be selected as the set-point.

The source to be used must be selected in advance via the entries in object 0x2331.

Tab. 29: Selection of discrete sources in object 0x2330 (discrete references)

Value	Voltage (0x2331.01)	Torque (0x2331.02)	Speed (0x2331.03)	Position (0x2331.04)
00	No source selected			
01	AnIn1 <sup>a)</sup>			
02	AnIn2 <sup>a)</sup>			
03-06	Reserved			
07	PwmIn <sup>a)</sup>			
08	Not supported	Not supported	Motor encoder	
09	Not supported	Not supported	Additional encoder <sup>b)</sup>	
10	Reserved			

a) Analog inputs and the PWM input must be converted via the user-defined scaling into a suitable set-point.

b) The position of the additional encoder can be converted via the user-defined scaling within the object 0x2316.04 into a value suitable for the actual position value.

#### 4.7.2.1 Examples for selection of discrete set-points

##### Setting an additional encoder with incremental encoder as the set-point source (gearing mode)

Analog Hall sensors with a resolution of 4096 increments per motor revolution are used as actual value encoders. The target position should be specified via a quadrature signal of a master encoder. The connected motor should perform one revolution at 1000 increments of the external encoder. This corresponds to 4096 increments of the analog Hall sensor.

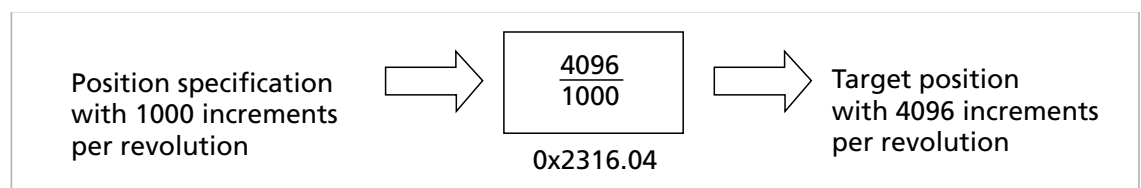

- ✓ The additional encoder is configured as an incremental encoder via the object 0x2316 (see chap. 4.6, p. 49).
- ✓ Additional encoder is connected to an EncA = DigIn1 and EncB = DigIn 2 and the switching threshold is set appropriately.
- ▶ Configure the scaling of the set-point to suit (numerator = 4096, denominator = 1000):
  - In the object 0x2316.04, set the value **0x10 00 03 E8**.
- ▶ Configure the APC operating mode:
  - In the object 0x6060.00, set the value **-2**.

## Configuring and starting the drive

- ▶ Select the additional encoder as the set-point source:

- In the object 0x2331.04, set the value **09**.

- ↩ The additional encoder with incremental encoder is now configured as the set-point source.

-  The count direction for the additional encoder can be adapted with a negative sign in the numerator of the scaling (0x2316.04).

### Configuring the additional encoder connected to a pulse generator as the set-point source (stepper mode)

Analog Hall sensors with a resolution of 4096 increments per motor revolution are used as actual value encoders. The connected motor should perform one revolution at 1000 increments of the external encoder. This corresponds to 4096 increments of the analog Hall sensor.

- ✓ The additional encoder is configured as a pulse counter via the object 0x2316 (see chap. 4.6, p. 49).
- ✓ The pulse generator is connected to DigIn1.
- ✓ The rotation direction input is connected to DigIn2.
- ✓ Switching thresholds are set appropriately.
- ▶ Configure the scaling of the set-point to suit (numerator = 4096, denominator = 1000):
  - In the object 0x2316.04, set the value **0x10 00 03 E8**.
- ▶ Configure the APC operating mode:
  - In the object 0x6060.00, set the value **-2**.
- ▶ Select the additional encoder as the set-point source:
  - In the object 0x2331.04, set the value **09**.
- ↩ The additional encoder with connected pulse generator is now configured as the set-point source.

## Configuring and starting the drive

### Analog set-point

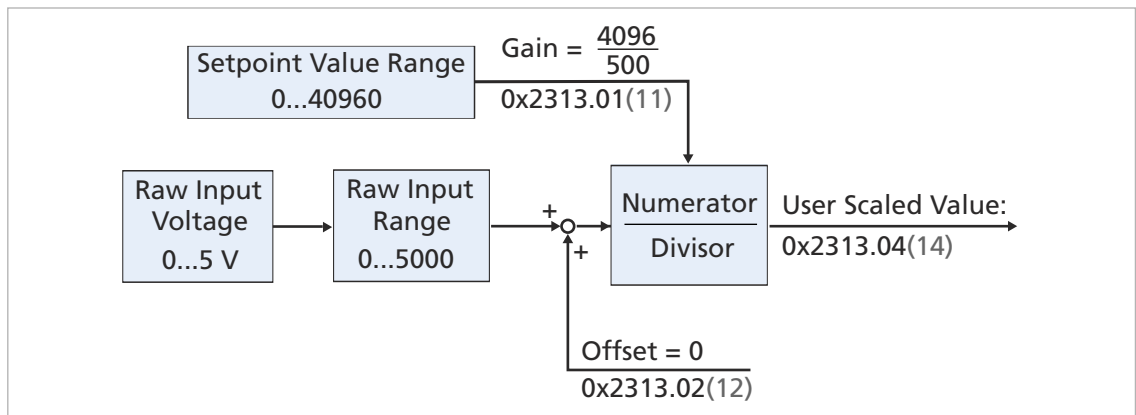

Fig. 22: Setting an analog input for discrete set-points

A voltage set by a potentiometer is to be used as the target position. The minimum voltage is 0 V, the maximum voltage is 5 V. With no application of user-defined scaling this corresponds to a numeric range of 0 ... 5,000. The motor position is resolved via the motor encoder with 4096 increments per revolution. This should be able to cover a setting range of 10 revolutions. The set-point range must therefore be from 0 ... 40960.

- ▶ Set the user-defined scaling.
  - Depending on the analog input, set an offset of 0 in the object 0x2313.02 or 0x2313.12.
  - In the object 0x2313.01 or 0x2313.11, set the gain:
 
$$\text{Gain} = \frac{\text{Max. target position}}{\text{Max. raw numeric value}} = \frac{40960}{5000}$$
 must be reduced to: 4096/500
- ▶ In the object 0x6060.00, set the value -2.
  - ↻ The APC operating mode is selected.
- ▶ Configure a discrete set-point source:
  - For AnIn1, set the value 01 in object 0x2331.04.
  - For AnIn2, set the value 02 in object 0x2331.04.
- ↻ The analog input is now set as the input for the discrete set-points.

**i** A rotation direction input can be assigned to each analog input via 0x2313.x8. With a low level on the rotation direction input, the raw value of the input is inverted.

## Configuring and starting the drive

### Analog set-point specification for the speed

A speed set-point of  $\pm 3000 \text{ min}^{-1}$  is to be calculated from a voltage 0...5 V.

- ▶ Enter offset **-2500** in object 0x2313.02.

The raw value range is 0...5000. With a raw value of 2500 (2.5 V), the output is to be  $0 \text{ min}^{-1}$ . Thus, the raw value range must be shifted by 2500 in the negative direction.

- ▶ In object 0x2313.01, enter the value **6000/5000** for the gain as a combination of numerator and denominator.

The value for the gain results from the quotient of output value range and input value range:

- Output value range:  $-3000 \text{ min}^{-1} \dots +3000 \text{ min}^{-1} \rightarrow$  Numerator = 6000
- Input value range: 0...5000  $\rightarrow$  Denominator = 5000

- ▶ Set 0x6060.00 = **-3** to select analog speed control as operating mode.

- ▶ Set 0x2331.03 = **1** to select AnIn 1 as the set-point source for the speed.

### Analog set-point specification for the position

A position set-point from  $-2048 \dots +2047$  (1 revolution for analog Hall) is to be calculated from a voltage 0...5 V.

- ▶ Enter offset **-2500** in object 0x2313.02.

The raw value range is 0...5000. With a raw value of 2500 (2.5 V), the output is to be  $0 \text{ min}^{-1}$ . Thus, the raw value range must be shifted by 2500 in the negative direction.

- ▶ In object 0x2313.01, enter the value **4096/5000** for the gain as a combination of numerator and denominator.

The value for the gain results from the quotient of output value range and input value range:

- Output value range:  $-2048 \dots +2047 \text{ Inc} \rightarrow$  Numerator = 4096
- Input value range: 0...5000  $\rightarrow$  Denominator = 5000

- ▶ Set 0x6060.00 = **-2** to select analog position control as operating mode.

- ▶ Set 0x2331.04 = **1** to select AnIn 1 as the set-point source for the position.

## Configuring and starting the drive

### Set-point specification for the speed via a PWM value

A speed set-point of  $\pm 5000 \text{ min}^{-1}$  is to be calculated from a PWM on DigIn1 with 10...90%.

- ▶ Enter offset **-16384** in object 0x2317.05.

The raw value range is 0...32767 (0...100%). With a raw value of 16384 (50%), the output is to be  $0 \text{ min}^{-1}$ . Thus, the raw value range must be shifted by 16384 in the negative direction.

- ▶ In object 0x2317.04, enter the value **10000/26214** for the gain as a combination of numerator and denominator.

The value for the gain results from the quotient of output value range and input value range:

- Output value range:  $-5000 \text{ min}^{-1} \dots +5000 \text{ min}^{-1} \rightarrow \text{Numerator} = 10000$
- Input value range: 80 % of 32767  $\rightarrow \text{Denominator} = 26214$
- ▶ Set 0x6060.00 = **-3** to select analog speed control as operating mode.
- ▶ Set 0x2331.03 = **7** to select PWM as the set-point source for the speed.
- ▶ Set 0x2317.01 = **1** to select DigIn 1 as the source for PWM.



## Configuring and starting the drive

### 4.8 Factor Group

The objects of the Factor Group are used to convert internal position values or speed values into user-defined units.

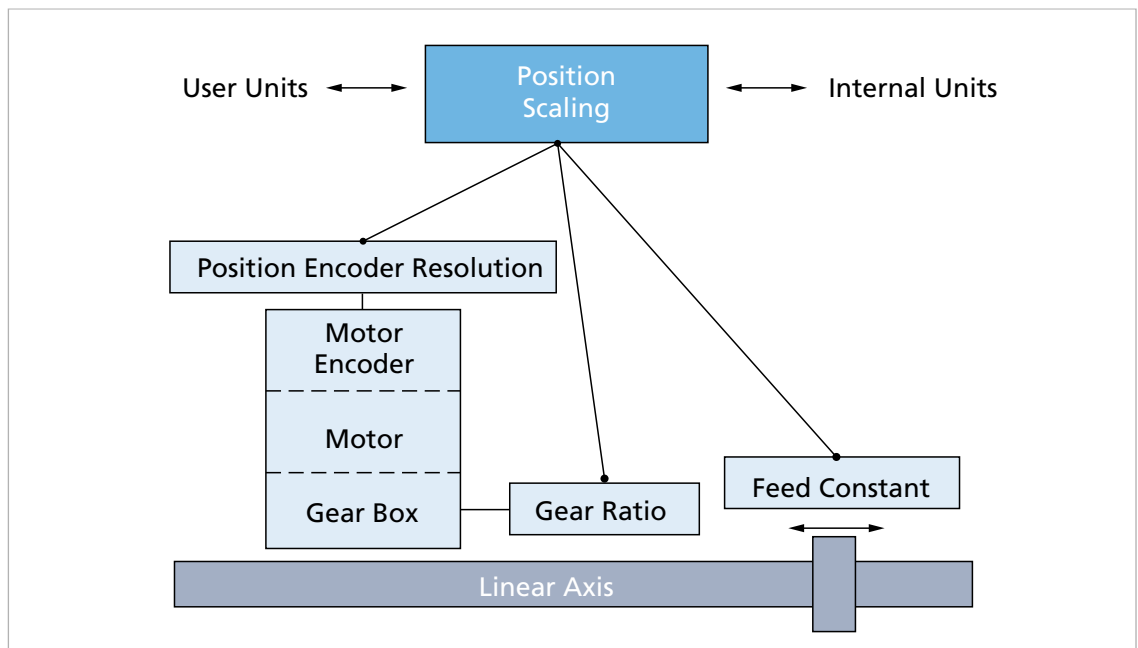
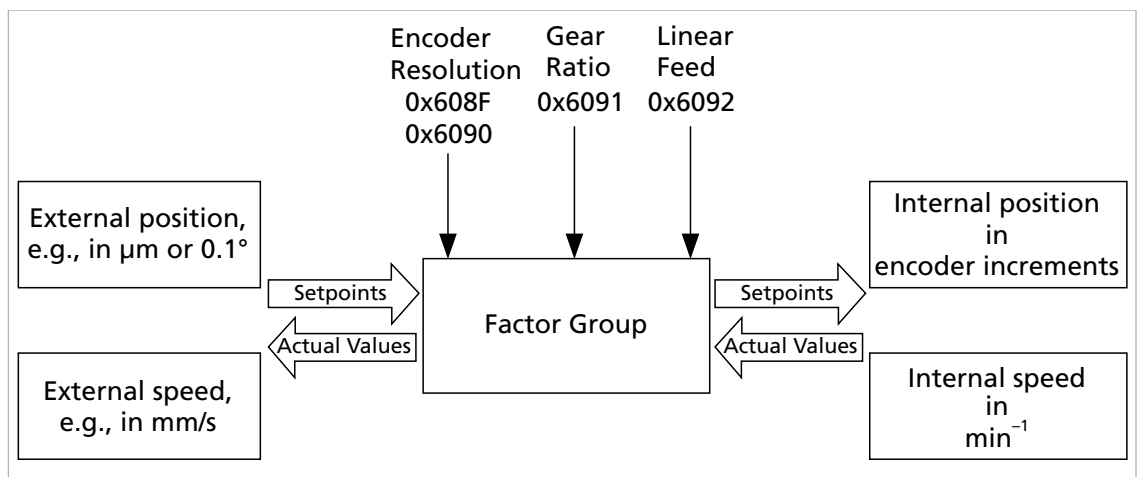

Fig. 23: Calculation of the factor group

The factor group thereby automatically takes into account the set resolution of the position encoder.



## Configuring and starting the drive

Tab. 30: Typical settings for the external position

Scaling	Description	Configuration
Delivery state	If no further settings are made, the internal resolution is also directly used externally	Feed (0x6092): Resolution of the internal encoder. Gear ratio (0x6091): 1:1
µm	For linear movements	Feed (0x6092): Pitch of the linear feed, e.g., 1500 for 1.5 mm pitch per lead screw revolution.
0.1°	For rotary movements	Feed (0x6092): 3600 corresponding to 3600 x 0.1° per revolution

**i** In addition to the set-points and actual values of the position, the following values are also specified in the external scalings:

- Position monitors (Position Window) and following errors
- Position limits and position ranges
- Homing offset
- Touch probe position (from firmware version K1)

Tab. 31: Typical settings for the external speed

Scaling	Description	Configuration
Delivery state	If no further settings are made, the speed is evaluated in min <sup>-1</sup>	Velocity Factor (0x6096): Reciprocal of the encoder resolution Velocity factor = (encoder resolution) <sup>-1</sup>
mm/s	For linear movements	Velocity factor (0x6096): see Tab. 32 Velocity factor = (60 x 1000) <sup>-1</sup>

**i** In addition to the set-points and actual values of the speed, the speed monitors (Velocity Window, Velocity Threshold, Velocity Deviation Window) are specified in the external scalings.

The relationship between the user-defined units and internal position values is described by the following formula (values shown in blue are configurable):

$$\text{Position Value} = \text{Position Internal Value} * \frac{\text{Feed Constant}}{\text{Position Encoder Resolution} * \text{Gear Ratio}}$$

The relationship between the user-defined units and the internal speed values is given by the following formula:

$$\text{Velocity Value} = \text{Velocity Internal Value} * \frac{\text{Feed Constant}}{\text{Gear Ratio}} * \text{Velocity Factor}$$

The meanings of the parameters are as follows:

- Velocity Internal Value: The speed of the motor in min<sup>-1</sup>.
- Position Encoder Resolution: The resolution of the encoder used for position control, in increments per motor revolution.
- Gear Ratio: The transmission ratio of a gearhead attached to the motor.
- Feed Constant: The feed of the axis in user-defined units per revolution of the gearhead output shaft.

## Configuring and starting the drive

- Velocity Factor: A scaling factor for the speed which permits scaling of the speed independently of the position representation.

 If no gearhead is fitted, a ratio of 1:1 must be set (default value).

 If a position resolution set by the Factor Group is different from the internal resolution, the position limits must be configured as required, since these may no longer be achievable.

### Example: Position resolution different from the internal resolution

The internal position can reach a maximum of 532 values ( $\pm 2147483647$ ).

With a gear ratio of 14:1, the motor must perform 14 revolutions for one revolution of the output.

- ✓ The encoder resolution is set (e. g. 2048 increments per revolution).
- ✓ The gear ratio 14:1 is set in the Factor Group.
- ▶ Specify new set-point of 1000 increments.
  - ↪ Internally the motor will rotate by 14,000 increments, since the position set-point is always interpreted as an instruction in scaling at the output.  
The internal position would have been able to travel 14 x 532. The possible value range is thereby exceeded.
- ▶ Adjust software position limits.

### 4.8.1 Position Encoder Resolution

$$\text{Position Encoder Resolution} = \frac{\text{Encoder Increments}}{\text{Motor Revolutions}}$$

 All units are dimensionless.

#### Position Encoder Resolution

Index	Subindex	Name	Type	Attr.	Default value	Meaning
0x608F	0x00	Number of Entries	U8	ro	2	Number of object entries
	0x01	Encoder Increments	U32	ro	4096	Encoder increments
	0x02	Motor Revolutions	U32	ro	1	Motor revolutions

 The resolution of the encoder is set in the objects for configuration of the connected position encoder (see chap. 4.6, p. 49). The encoder used for the position control system is set via the object 0x2330.03 (see chap. 4.7, p. 57).

## Configuring and starting the drive

### 4.8.2 Velocity Encoder Resolution

The Velocity Encoder Resolution (0x6090) object specifies the ratio of encoder increments to the number of motor revolutions.

$$\text{Velocity Encoder Resolution} = \frac{\text{Encoder} * \frac{\text{Increments}}{\text{Sec}}}{\text{Motor} * \frac{\text{Revolutions}}{\text{Sec}}}$$

 All units are dimensionless.

#### Velocity Encoder Resolution

Index	Subindex	Name	Type	Attr.	Default value	Meaning
0x6090	0x00	Number of Entries	U8	ro	2	Number of object entries
	0x01	Encoder Increments	U32	ro	4096	Position resolution of the set sensor
	0x02	Motor Revolutions	U32	ro	1	Number of motor revolutions for the impulse number specified in subindex 1

 The resolution of the encoder is set in the objects for configuration of the connected position encoder (see chap. 4.6, p. 49). The encoder used for the speed control is set via the object 0x2330.02 (see chap. 4.7, p. 57).

### 4.8.3 Velocity factor

The velocity factor is used to adapt the internal scaling to the user-defined units. The velocity factor is calculated as follows:

$$\text{Velocity Factor} = \frac{\text{Feed Velocity Units}}{\text{Feed Pos. Units}} * \frac{\text{Minutes}}{\text{User Time Units}}$$

The velocity factor consists of two parts:

$\frac{\text{Feed Speed Units}}{\text{Feed Pos. Units}}$  Converts the different reference ranges for the position and the speed (see chap. 4.8.7, p. 71).

$\frac{\text{Minutes}}{\text{User Time Units}}$  Converts the speed shown internally in  $\text{min}^{-1}$  into the desired time-based resolution.

## Configuring and starting the drive

**i** If the motor is being configured using the motor wizard of the Motion Manager, the velocity factor and feed constants are pre-set:

$$\text{Feed Constant} = \frac{\text{Position Encoder Resolution}}{1}$$

$$\text{Velocity Factor} = \frac{1}{\text{Position Encoder Resolution}}$$

Thus the position is available initially in increments of the motor encoder, and the speed in  $\text{min}^{-1}$ .

### Velocity factor

Index	Subindex	Name	Type	Attr.	Default value	Meaning
0x6096	0x00	Number of Entries	U8	ro	2	Number of object entries
	0x01	Numerator	U32	rw	1	Numerator
	0x02	Divisor	U32	rw	4096	Denominator

Tab. 32: Typical assignment of the velocity factor

Drive type	Feed	Feed speed units/ Feed position units	Minutes/User time units	Velocity factor
Rotatory	Encoder resolution (e.g. 4096)	1/4096	1	1/4096
Linear motor (e.g. LM 1247)	Magnetic pole width in $\mu\text{m}$ (e.g. 18000)	1/1000	1/60	1/(1000*60)
Lead screw (e.g. BS 22 1.5)	Pitch in $\mu\text{m}$ (e.g. 1500)	1/1000	1/60	1/(1000*60)

### 4.8.4 Gear Ratio

The Gear Ratio (0x6091) object specifies the ratio of motor revolutions to the number of output revolutions:

$$\text{gear ratio} = \frac{\text{motor shaft revolutions}}{\text{driving shaft revolutions}}$$

**i** All units are dimensionless.

### Gear Ratio

Index	Subindex	Name	Type	Attr.	Default value	Meaning
0x6091	0x00	Number of Entries	U8	ro	2	Number of object entries
	0x01	Motor Shaft Revolutions	U32	ro	1	Revolutions of the gearhead input shaft
	0x02	Driving Shaft Revolutions	U32	rw	1	Revolutions of the gearhead output shaft

## Configuring and starting the drive

### 4.8.5 Feed Constant

The Feed Constant (0x6092) object specifies the ratio of feed to the number of output shaft revolutions:

$$\text{feed constant} = \frac{\text{feed}}{\text{driving shaft revolutions}}$$

**i** The feed is stated in user-defined units. The revolutions of the output shaft are dimensionless.

#### Feed Constant

Index	Subindex	Name	Type	Attr.	Default value	Meaning
0x6092	0x00	Number of Entries	U8	ro	2	Number of object entries
	0x01	Feed	U32	rw	4096	Feed
	0x02	Shaft Revolutions	U32	rw	1	Revolutions

### 4.8.6 Polarity

The Polarity (0x607E) object multiplies the set-point by 1 or -1 and is bit-coded. 0x80 inverts the position values, 0x40 inverts the speed values.

**i** In the PP, PV, CSP and CSV operating modes, the Polarity object acts on the set-points and actual values for speed and position.

#### Polarity (0x607E)

Index	Subindex	Name	Type	Attr.	Default value	Meaning
0x607E	0x00	Polarity	U8	rw	0	Bit-coded

#### Example

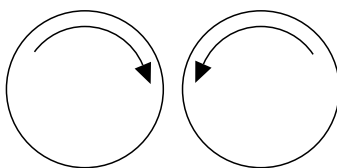

If, in an application, two axes are to be operated exactly opposite one another, both axes can be written by the master with the same set-point. The direction of rotation is inverted for one of the axes via the Polarity object.

**i** The Polarity object does not act on the movement direction during a reference run.

## Configuring and starting the drive

### 4.8.7 Examples of the factor group

#### 4.8.7.1 General - conversion of a position

Internally the position of the drive is held in increments of the position encoder that is used. The number of revolutions of the motor shaft is counted in encoder increments per revolution of the motor.

The factor group can be used to convert the internally used units to an application-specific representation, e.g., to the distance unit  $\mu\text{m}$ .

In rotary systems, the position can be uniformly specified for a whole group of drives via the factor group regardless of the resolution of the position encoder, e. g. in  $0.1^\circ$  rotation of the output shaft, even with an additional attached gearhead.

Using the following calculation rule an internal position is converted into an application-oriented position:

$$Position_{User} = Polarity * \frac{Feed}{Shaft Rev.} * \frac{Gear Shaft Rev.}{Motor Rev.} * \frac{Motor Rev.}{Encoder Increments} * Pos_{int}$$

Parameters are:

- The feed per revolution of the gearhead output:

$$Feed = \frac{Feed}{Shaft Rev.}$$

- The gear ratio:

$$Gear Ratio = \frac{Gear Shaft Rev.}{Motor Rev.}$$

- The resolution of the position encoder:

$$Position Encoder Resolution = \frac{Encoder Increments}{Motor Revolutions}$$

Thus the internal position in increments is initially converted into motor revolutions. The gear ratio is then used to determine the number of revolutions at the gearhead output. The feed constant is then used to determine the distance moved.

#### 4.8.7.2 General - conversion of a velocity

FAULHABER Motion Controllers calculate the speed of the motor internally in  $\text{min}^{-1}$ .

In addition the speed can be converted into a representation independently of the drive. The conversion uses information that has already been used for the conversion of the position (see chap. 4.8.7.1, p. 71):

$$Velocity_{User} = Polarity * \frac{Feed}{Shaft Rev.} * \frac{Gear Shaft Rev.}{Motor Rev.} * Velocity Factor * Velocity_{int}$$

The velocity factor is also used here (see chap. 4.8.3, p. 68).

## Configuring and starting the drive

### 4.8.7.3 Setting a DC motor with incremental encoder without a gearhead within a lead screw system

The following system is considered:

- In a lead screw system, the position should be specified in  $\mu\text{m}$ . The speed is specified in  $\text{mm/s}$ .
- A DC motor with incremental encoder is used.
- The incremental encoder has a resolution of 512 pulses.
- No gearhead is connected.
- The lead screw has pitch of 1.5 mm per revolution.
- ✓ The motor type is specified in the object 0x2329 or in the Motion Manager.
- ✓ The incremental encoder is configured in the object 0x2315 with a resolution of 2048 increments per revolution (see chap. 4.6, p. 49)
- ✓ The incremental encoder is configured as a position and speed sensor in the object 0x2330.

 If the motor and sensor system are configured using the Motion Manager motor selection wizard, all the settings will be correctly pre-set.

 The resolution of the sensor can be read from the objects in the factor group.

- Position encoder:
  - 0x608F.01=2048
  - 0x608F.02 = 1
- Velocity encoder:
  - 0x6090.01 = 2048
  - 0x6090.02 = 1

 By means of the quadrature signal, the resolution is 4 times the line count of the encoder.

- ▶ Set the feed in object 0x6092:
  - Set the value **0x05DC (1500)** for the pitch of the lead screw in object 0x6092.01.
  - Set the value **0x0001 (1)** for the lead screw revolutions in object 0x6092.02.
- ▶ In object 0x6096, set the velocity factor:
  - Feed position units = 1000 ( $\mu\text{m}$ )
  - Feed velocity units = 1 (mm)
  - User time units = 60 (s/min)

 The factor group is set to suit the application.





## Configuring and starting the drive

### 4.8.7.4 Setting a DC motor with incremental encoder and gearhead within a lead screw system

The following system is considered:

- In a lead screw system, the position should be specified in  $\mu\text{m}$ . The speed is specified in  $\text{mm/s}$ .
- A DC motor with incremental encoder is used.
- The incremental encoder has a resolution of 512 lines.
- A gearhead with a ratio of 14:1 is available.
- The lead screw has pitch of 1.5 mm per revolution.
- ✓ The motor type is specified in the object 0x2329 or in the Motion Manager.
- ✓ The incremental encoder is configured in the object 0x2315 with a resolution of 2048 increments per revolution (see chap. 4.6, p. 49)
- ✓ The incremental encoder is configured as a position and speed sensor in the object 0x2330.

 If the motor and sensor system are configured using the Motion Manager motor selection wizard, all the settings will be correctly pre-set.

 The resolution of the sensor can be read from the objects in the factor group.

- Position encoder:
  - 0x608F.01=2048
  - 0x608F.02 = 1
- Velocity encoder:
  - 0x6090.01 = 2048
  - 0x6090.02 = 1

 By means of the quadrature signal, the resolution is 4 times the line count of the encoder.

- ▶ Set the gear ratio in object 0x6091:
  - Set the value **0x000E (14)** for the number of motor revolutions per output shaft revolution in the object 0x6091.01.
  - Set the value **0x0001 (1)** for the number of output shaft revolutions in the object 0x6091.02.
- ▶ Set the feed in object 0x6092:
  - Set the value **0x05DC (1500)** for the pitch of the lead screw in object 0x6092.01.
  - Set the value **0x0001 (1)** for the lead screw revolutions in object 0x6092.02.

## Configuring and starting the drive

- ▶ In object 0x6096, set the velocity factor:
  - Feed position units = 1000 (μm)
  - Feed velocity units = 1 (mm)
  - User time units = 60 (s/min)

↶ The factor group is set to suit the application.

### 4.8.7.5 Setting the linear motor with analog Hall sensors

The following system is considered:

- In a linear drive system, the position should be specified in μm. The speed is specified in mm/s.
- A linear motor LM1247 with a magnetic pole width of 18 mm is used.
- Hall sensors are used for the actual value of the following values:
  - Commutation angle
  - Speed
  - Position

✓ The motor type is specified in the object 0x2329 or in the Motion Manager.

✓ The analog Hall sensors are configured as actual value encoders.

 If the motor and sensor system are configured using the Motion Manager motor selection wizard, all the settings will be correctly pre-set.

 The resolution of the sensor can be read from the objects in the factor group.

- Position encoder:
  - 0x608F.01= 4096
  - 0x608F.02 = 1
- Velocity encoder:
  - 0x6090.01 = 4096
  - 0x6090.02 = 1
- ▶ Set the feed in object 0x6092:
  - Set the value **0x4650 (18000)** for the feed in object 0x6092.01.
  - Set the value **0x0001 (1)** for the reference variable in object 0x6092.02.
- ▶ In object 0x6096, set the velocity factor:
  - Feed position units = 1000 (μm)
  - Feed velocity units = 1 (mm)
  - User time units = 60 (s/min)

↶ The factor group is set to suit the application.

## Configuring and starting the drive

### 4.9 Configuration of the digital inputs and outputs

The digital inputs and outputs of the FAULHABER Motion Controller can be used flexibly.

**The following functions of the digital inputs are supported:**

- Connection of limit switches
- Direct referencing of the drives with a reference switch
- Connection of a set-point or actual value via a PWM signal at DigIn1 or DigIn2
- Connection of an additional 2-channel or 3-channel quadrature encoder to DigIn1-DigIn3
- Set-point specification for the position controller using a pulse/direction signal at DigIn1 and DigIn2
- Recording the current position in response to an edge at the input (touch probe)
- Free inputs for procedures that are programmable at the controller
- Default value of the polarity for an analog input (e.g. as rotation direction input)

**The following functions of the digital outputs are supported:**

- Output of an error signal
- Direct activation of a holding brake
- Output of a freely configurable diagnostic signal such as for the following applications:
  - Controller limitations
  - Temperature warnings
  - Display at standstill ( $n = 0$ )
  - Achievement of the target position
- Free outputs for procedures that are programmable at the controller

## Configuring and starting the drive

### 4.9.1 Setting the digital inputs

#### 4.9.1.1 Setting limit switches and reference switches

- ▶ Configure the digital input for the lower limit switch via a bit mask in the object 0x2310.01.

Tab. 1: Bit mask of the object 0x2310.01 (lower limit switch)

0x2310.01	In8	In7	In6	In5	In4	In3	In2	In1

- ▶ Configure the digital input for the upper limit switch via a bit mask in the object 0x2310.02.

Tab. 1: Bit mask of the object 0x2310.02 (upper limit switch)

0x2310.02	In8	In7	In6	In5	In4	In3	In2	In1

- ▶ Set the behavior on reaching the limit switch in the object 0x2310.03.

Index	Subindex	Name	Type	Attr.	Default value	Meaning
0x2310	0x03	Limit Switch Option Code	S16	rw	1	0: Drive comes to a standstill powerlessly 1: Brake ramp 2: Quick Stop 3: Stop at max. current 4: Stop with voltage = 0

- ▶ Set the digital input for the reference switch by entering the input number into the object 0x2310.04.

 Limit switches and reference switches are now set.

 If multiple inputs are set at the same time for the lower or upper limit switch, the function becomes active when one of the switches trips.

 The number of available digital inputs depends on the Motion Controller used.

 Only one reference switch may be selected.

## Configuring and starting the drive

### 4.9.1.2 General settings of the digital inputs

#### Setting the active level

- ▶ Use the flags in the object 0x2310.10 to set whether a high level or a low level at an input should be evaluated as an active level.
  - Input mask bit = 0: Input is not inverted (high = active)
  - Input mask bit = 1: Input is inverted (low = active)

Tab. 1: Bit mask of the object 0x2310.10

0x2310.10	In8	In7	In6	In5	In4	In3	In2	In1
-----------	-----	-----	-----	-----	-----	-----	-----	-----

↩ The active level is set.

#### Setting the trigger thresholds

- ▶ In object 0x2310.11, determine whether the trigger thresholds of the digital inputs should be 5 V TTL-compatible or 24 V PLC-compatible.
  - 0x2310.11 = 0: TTL level for all digital inputs
  - 0x2310.11 = 1: PLC level for all digital inputs

**i** The setting of the trigger thresholds is also effective if the digital inputs are used as a connection for a reference encoder.

↩ The trigger threshold is set.

#### Setting the filters at digital inputs

- ▶ Set filters for the digital input to be filtered using object 0x2310.12.
  - Input mask bit = 0: Filter deactivated (default)
  - Input mask bit = 1: Filter activated

Tab. 1: Bit mask of the object 0x2310.12

0x2310.12	In8	In7	In6	In5	In4	In3	In2	In1
-----------	-----	-----	-----	-----	-----	-----	-----	-----

**i** When a filter is activated, as change of level must be present for at least 4 ms before it is recognized as valid.

## Configuring and starting the drive

### 4.9.1.3 Configuring digital inputs DigIn1-DigIn3 as connections for an additional encoder

**i** If the additional encoder used is configured in the object 0x2316.01 as a pulse/direction input or as a 2-channel or 3-channel incremental encoder, the inputs are configured automatically.

**i** Functions set at digital inputs are also evaluated if an additional encoder is activated via 0x2316 or 0x2317.

So as to avoid malfunctions, the digital inputs used for the encoder may not be used as limit switches or reference switches.

**i** If an additional encoder is used, the voltage level setting for the digital inputs in the object 0x2310.11 is active and the logical level settings in the object 2310.10 are ineffective.

- ▶ Set the used additional encoder in the object 0x2316.01 (see chap. 4.6.2, p. 52).

### 4.9.2 Directly read the level of the digital inputs and outputs, or directly write the digital outputs

- ▶ In object 0x2311.01, read the logical state of the digital inputs having regard to the polarity from object 0x2310.10.

Tab. 33: Bit mask of the object 0x2311.01

0x2311.01	In8	In7	In6	In5	In4	In3	In2	In1
-----------	-----	-----	-----	-----	-----	-----	-----	-----

- ▶ In object 0x2311.02 directly read the physical state of the digital inputs. A high level at the input leads to a set bit in the mask.

Tab. 34: Bit mask of the object 0x2311.02

0x2311.02	In8	In7	In6	In5	In4	In3	In2	In1
-----------	-----	-----	-----	-----	-----	-----	-----	-----

- ▶ Directly read the logical state of the digital outputs in object 0x2311.03. A set output leads to a set bit in the mask.
- ▶ Directly set, toggle or delete a digital output in object 0x2311.04.

## Configuring and starting the drive

**Example:** Toggling digital output 3

- ▶ In the object 0x2311.04, set the value **0x00EF** (bit pattern 11 10 11 11).
  - ↪ Digital output 3 is now toggled.
  - The other digital outputs remain unchanged.

Tab. 35: Meaning of the bit pattern

0x2311.04	DigOut4		DigOut3		DigOut2		DigOut1	
	B1	B0	B1	B0	B1	B0	B1	B0

- B1|B0 = 00: Delete digital output
- B1|B0 = 01: Set digital output
- B1|B0 = 10: Toggle digital output
- B1|B0 = 11: Do not change digital output

### 4.9.3 Setting the digital outputs

#### 4.9.3.1 Setting the fault output

- ▶ Set the digital output to be used for the fault output in object 0x2312.01.
- ▶ Use the mask in object 0x2321.03 to configure which internal faults should trigger the fault signal (see chap. 7, p. 156).
- ↪ The fault output is set.

#### 4.9.3.2 Configuring the digital output as a brake activation

- i** If a holding brake is used, a waiting time may have to be applied before the output stage and control can be activated or deactivated. Thus, it may for instance be ensured that the brake has been reliably applied before the motor control is switched off.
- ▶ Set the digital output to be used for the brake activation in object 0x2312.02.
- ▶ Set the waiting time in object 0x2312.03.
- ↪ The digital output is now set as a brake activation.

#### 4.9.3.3 Set a digital output as a diagnostic output

To set a digital output as a diagnostic output, a bit mask must be defined in relation to the device statusword 0x2324.01 for each digital output used (see chap. 7, p. 156).

- i** If the bit-wise AND link of the bit mask with the statusword delivers a result > 0, the configured digital output is activated.

**Example:** The standstill of the drive is to be signaled via digital output 2

1. In the object 0x2312.08, set the value **0x02**.
  - ↪ Digital output 2 will be used.
2. In the object 0x2312.09, set the bit mask **0x00 00 00 01**.
  - ↪ Only at a standstill (n = 0) is an output switched.
  - ↪ At a standstill, firstly bit 0 is set (n=0) in object 0x2324.01. Output 2 is then set using the mask in object 0x2312.09.

## Configuring and starting the drive

### 4.9.3.4 Configuring the polarity of the digital outputs

- ▶ In the object 0x2312.10, set the polarity of a digital output.
  - Input mask bit = 0: A set digital output switches the output to ground. A low level is measured at the DigOut pin.
  - Input mask bit = 1: A set digital output switches the output into a high-resistance state. A high level is measured at the DigOut pin when the pin is switched by an external pull-up resistor connected to the supply.

Tab. 36: Bit mask of the object 0x2312.10

0x2312.10	Out8	Out7	Out6	Out5	Out4	Out3	Out2	Out1

### 4.9.4 Setting the digital input as a touch probe

The current position of a drive or a reference encoder can be recorded in response to an edge at a digital output configured as a touch probe. In addition the number of edges can be counted.

Tab. 37: Overview of the objects used

Index	Description	Attr.	Type
0x60B8	Configuration of the touch probe function	rw	U16
0x60B9	Status of the touch probe function	ro	U16
0x60BA	Position of the positive edge at input 1	ro	S32
0x60BB	Position of the negative edge at input 1	ro	S32
0x60BC	Position of the positive edge at input 2	ro	S32
0x60BD	Position of the negative edge at input 2	ro	S32
0x60D5	Counter of the positive edges at input 1	ro	U16
0x60D6	Counter of the negative edges at input 1	ro	U16
0x60D7	Counter of the positive edges at input 2	ro	U16
0x60D8	Counter of the negative edges at input 2	ro	U16



## Configuring and starting the drive

### Configuration of the touch probe inputs

In total up to two inputs can be configured as a touch probe function. The configuration is performed using the object 0x60B8.

	Standard	Option	Distribution of the bits in object 0x60B8
Touch Probe 1	DigIn2	Encoder index	U8 (bits 7...0)
Touch Probe 2	DigIn3	Encoder index	U8 (bits 15...8)

Tab. 38: Meaning of the bits in the object 0x60B8 (touch probe function)

Touch Probe 1	Touch Probe 2	Meaning
Bit 0	Bit 8	Enable 0: Touch probe function switched off 1: Touch probe function activated
Bit 1	Bit 9	Trigger mode 0: Only the first edge is recorded 1: Edges are continuously recorded and counted
Bits 3 2	Bits 11 10	Trigger source 00: The digital input is evaluated as a trigger 01: The index of the position encoder selected using 0x2330.03 is evaluated as a trigger 10: Not used 11: Not used
Bit 4	Bit 12	Positive edge active 0: No evaluation of the positive edge 1: Recording of the positive edge activated
Bit 5	Bit 13	Negative edge active 0: No evaluation of the negative edge 1: Recording of the negative edge activated
Bits 7 6	Bits 15 14	Position source 00 01: The current motor position is saved as the position. The position is updated every 100 µs. 10: The current position of the reference encoder is saved as the position. The position is thus updated directly at the input edge 11: Not used

## Configuring and starting the drive

### Status of the Touch Probe inputs

As for the configuration of the touch probe inputs, the status of the two possible channels is also combined in one object.

*Tab. 39: Meaning of the bits in the object 0x60B9*

Touch Probe 1	Touch Probe 2	Meaning
0	8	Enable 0: Switched off 1: Activated
1	9	Positive edge recorded 0: No positive edge has yet been recorded 1: At least one positive edge has been recorded
2	10	Negative edge recorded 0: No negative edge has yet been recorded 1: At least one negative edge has been recorded
5 4 3	13 12 11	Reserved 000
7 6	15 14	Not used 00

### Restrictions

- Touch input 1 evaluates DigIn2 as a trigger input. Combination with an external reference encoder (DigIn1 and DigIn2) is thus not possible.
- Touch input 2 can also be combined with a reference encoder.
- The same trigger cannot be used for both touch inputs. Permissible combinations are:

*Tab. 40: Possible combinations of trigger sources when using two touch probe inputs*

Touch Probe 1	Touch Probe 2
Digital input (DigIn 2)	Digital input (DigIn 3)
Index	Digital input (DigIn 3)
Digital input (DigIn 2)	Index

## Configuring and starting the drive

### 4.10 Configuration of analog inputs

The analog inputs of the Motion Controller can process electrical signals in the level range  $\pm 10$  V. Internally the signals are shown as numeric values  $\pm 10,000$  equivalent to  $\pm 100$  %. The scaling factor can be using object 0x2313. The values are updated every 1 ms.

**i** If the analog inputs are used as set-point or actual value encoders, the values from the analog input must be converted into a suitable physical variable.

**i** The raw value of the analog input can be subjected to a low pass 1st order filter before further processing.

**i** The filtered raw values can be read in the following objects:

- AnIn1: 0x2314.07
- AnIn2: 0x2314.08

The scaled end value can be read using the object 0x2313.04 or 0x2313.14.

If a polarity input is used, the following rule applies:

- Logic level = High, the limited raw value is multiplied by +1
- Logic level = Low, the limited raw value is multiplied by -1

Tab. 41: User scalings

Index	Subindex	Name	Type	Attr.	Default value	Meaning
0x2313	0x00	Number of Entries	U8	ro	21	Number of object entries
	0x01	AnIn 1 Gain (Numerator/ Divisor)	S32	rw	0x7FFF8000	AnIn 1 gain (numerator/denominator) <ul style="list-style-type: none"> <li>■ Bit 0...15: Numerator</li> <li>■ Bit 16...31: Denominator</li> </ul>
	0x02	AnIn 1 Offset	S16	rw	0	AnIn 1 offset
	0x03	AnIn 1 Filter Time	U16	rw	0	AnIn 1 filter time in 100 $\mu$ s
	0x04	AnIn 1 User Scaled Value	S32	ro	-	Scaled AnIn 1 value
	0x05	AnIn 1 Resolution as Encoder	U16	rw	1000	AnIn 1 resolution of the encoder
	0x06	AnIn 1 Min Input Limit	S16	rw	-32768	AnIn 1 lower limit for the input value
	0x07	AnIn 1 Max Input Limit	S16	rw	32767	AnIn 1 upper limit for the input value
	0x08	AnIn 1 Select Dir Pin	U8	rw	0	AnIn 1 polarity input: 0: No polarity input used 1...8: Digital input used as polarity input
	0x09	AnIn 1 Virtual Input Value	S16	rw	0	AnIn 1 simulated input value
	0x0A	AnIn 1 Enable Virtual Input	U8	rw	0	AnIn 1 simulated input value activated
	0x11	AnIn 2 Gain (Numerator/ Divisor)	S32	rw	0x7FFF8000	AnIn 2 gain (numerator/denominator) <ul style="list-style-type: none"> <li>■ Bit 0...15: Numerator</li> <li>■ Bit 16...31: Denominator</li> </ul>

## Configuring and starting the drive

Index	Subindex	Name	Type	Attr.	Default value	Meaning
	0x12	AnIn 2 Offset	S16	rw	0	AnIn 2 offset
	0x13	AnIn 2 Filter Time	U16	rw	0	AnIn 2 filter time in 100 $\mu$ s
	0x14	AnIn 2 User Scaled Value	S32	ro	-	Scaled AnIn 2 value
	0x15	AnIn 2 Resolution as Encoder	U16	rw	1000	AnIn 2 resolution of the encoder
	0x16	AnIn 2 Min Input Limit	S16	rw	-32768	AnIn 2 lower limit for the input value
	0x17	AnIn 2 Max Input Limit	S16	rw	32767	AnIn 2 upper limit for the input value
	0x18	AnIn 2 Select Dir Pin	U8	rw	0	AnIn 2 polarity input: 0: No polarity input used 1...8: Digital input used as polarity input
	0x19	AnIn 2 Virtual Input Value	S16	rw	0	AnIn 2 simulated input value
	0x1A	AnIn 2 Enable Virtual Input	U8	rw	0	AnIn 2 simulated input value activated

### Example: Configuring the scaling of the ADC end value

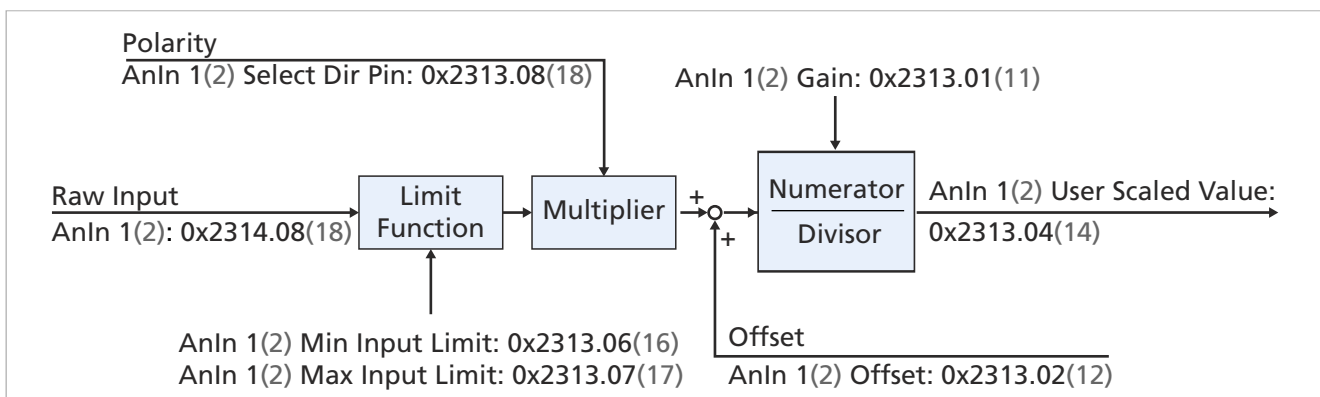

**i** Depending on the selected scaling, even output values  $>S32$  ( $\pm 2147483647$ ) can be achieved. The output value is then wrapped to the opposite end of the value range.

To prevent this, the input limits must be changed appropriately.

The objects 0x2313.01 and 0x2313.11 (AnIn gain) allow the raw values of the analog inputs to be converted into internal units.

The objects 0x2313.02 and 0x2313.12 (AnIn offset) can be used additionally to specify offset displacements.

- Intermediate values and end values are signed 32-bit variables.
- Raw values, offsets and the numerator are signed 16-bit variables.
- The denominator is an unsigned 16-bit variable.

## Configuring and starting the drive

### Example: Filtering the ADC raw value of the AnIn1 with a filter time of 2.5 ms

- ▶ In the object 0x2313.03, set the value **25** (unit 100  $\mu$ s).
  - ↗ The ADC raw value of the AnIn1 will now be filtered with a filter time of 2.5 ms.

**i** For examples on the use of analog inputs as set-point value for the control, see chap. 4.7, p. 57.

### 4.10.1 Simulating analog input values

The behavior of the analog inputs can be simulated by writing a simulated value for the input voltage in object 0x2313.x9 and activating the simulated input value via 0x2313.xA.

#### Configuration

- Setting an emulated voltage value:

Channel	Object	Value range
AnIn1	0x2313.09	S16
AnIn2	0x2313.19	S16

- Activating an emulated voltage:

Channel	Object	Value range
AnIn1	0x2313.0A	= 0: Simulation not active > 0: Simulation active
AnIn2	0x2313.1A	

#### Example: Testing analog speed control via AnIn1

- ✓ AVC mode is set
- ✓ AnIn1 is appropriately scaled and set as set-point
- ✓ Output stage and control are activated
- ▶ If necessary, use the following objects to limit the input value to the expected voltage range:
  - 0x2313.06 (lower limit)
  - 0x2313.07 (upper limit)
- ▶ Set the emulated voltage value in the expected voltage range.
  - ↗ The drive runs at the speed that corresponds to the emulated voltage value.

## Configuring and starting the drive

### 4.10.2 Using analog inputs as digital inputs

The analog inputs of the Motion Controller can be used as digital inputs.

#### Configuration

- Activating emulated inputs:

The emulated digital inputs are activated via object 0x2300.04 (number of emulated digital inputs).

0x2300.04	DigIn4	DigIn5
0	–	–
1	Emulated via AnIn1	–
2	Emulated via AnIn1	Emulated via AnIn2

- Switching thresholds:

The switching thresholds are configured separately for each emulated channel via object 0x2310.05.

Bit 7	Bit 6	Bit 5	Bit 4	Bit 3	Bit 2	Bit 1	Bit 0
–	–	–	–	–	–	AnIn2	AnIn1

Value of the bit	Electronics	Switching thresholds
0	TTL	Low: 0.5 V High: 2.0 V
1	PLC	Low: 4.0 V High: 7.5 V

#### Application

Emulated digital inputs are updated every 1 ms. They can be used as inputs for limit switches or as free digital inputs.

## Configuring and starting the drive

### 4.11 Operation with safety function

The information in this chapter can only be used on Motion Controllers with safety function. Motion Controllers with safety function can be identified by the designation STO in the product name (e.g., MC 5004 P STO CO).



#### WARNING!

#### Risk of injury if drive system is of inadequate design

The proper use of the safety function of the Motion Controller alone is not sufficient for enabling safe interaction with the drive system.

- ▶ Before setting up the drive system, make certain that it poses no danger.

The safety function of the drive system is ensured through redundant activation. The STO IN 1 and STO IN 2 inputs are used for this purpose.

Outputs *Status* and *No-Error* are represented by both the digital STO outputs as well as by the LEDs mounted on the Motion Controller and indicate the state of the safety function. The positions of the LEDs and their combinations are described in the installation instructions.



The connection of the STO inputs and outputs is described in the installation instructions for the MC 5004 P STO.

The state of the safety function is returned via object 0x2390.01. Activation of the state machine is triggered by a reset via object 0x2390.02.

Error states and error reactions can be connected to an EMCY error message as described in Tab. 67. For error handling, see chap. 7.2.2, p. 161.

#### Safety objects (0x2390)

Index	Subindex	Name	Type	Attr.	Default value	Meaning
0x2390	0x00	Number of Entries	U8	const	2	Number of object entries
	0x01	STO State	U8	ro	–	Status of the STO safety function (Safe Torque Off) 0: STO ON 1: Error 16: STO OFF 17: Powerdown
	0x02	STO Reset	U8	wo	–	STO reset pulse for changing to the operating state after an error 1: Activate reset

#### Activating the output stage

- ✓ The device is electrically connected according to the information in the installation instructions.
  - ✓ The device is in the *Error* state (object 0x2390.01 = 01), i.e., both inputs (STO IN 1 and STO IN 2) are deactivated.
1. In object 0x2390.02 (STO Reset), set value 0x01 (bit pattern 00 00 00 01).
    - ↗ The reset pulse is triggered by writing the object.
    - The device changes to the *STO ON* state (object 0x2390.01 = 00).

## Configuring and starting the drive

2. Activate both inputs: STO IN 1 and STO IN 2 (see installation instructions).
  - ↻ The device changes to the *STO OFF* state (object 0x2390.01 = 10).  
This state is depicted by the active output *No-Error*. The *Status* output is deactivated.
  - ↻ The drive can now be used via the state machine and object 0x6040.00.

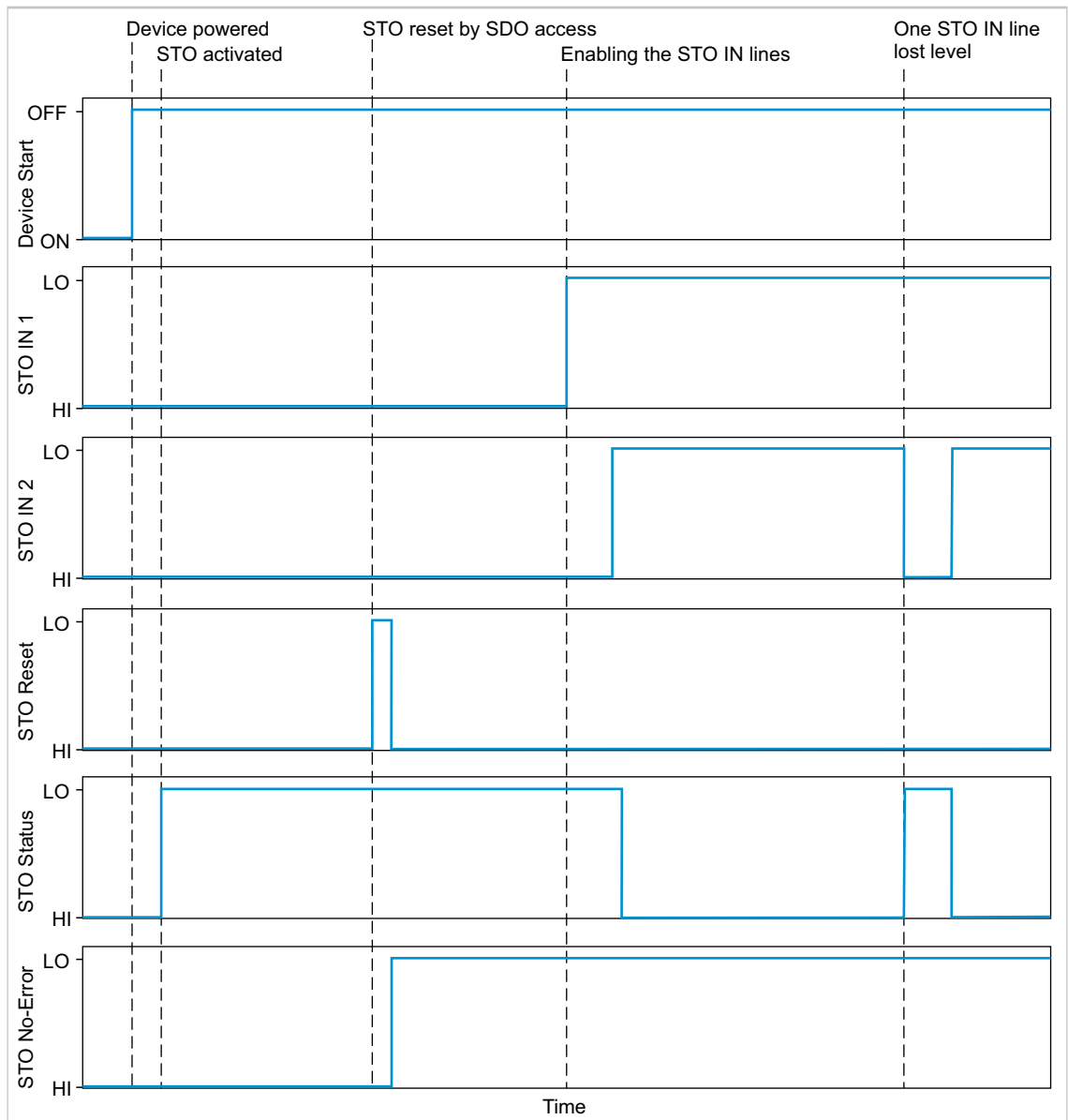



Fig. 24: Activating the safety function

For further information on the safety function, see the installation instructions.



## Configuring and starting the drive

### 4.12 Data record management

 The configuration settings performed in the Motion Manager can be permanently saved in the controller, so that they are available when the drive is switched on again.

#### 4.12.1 Saving and restoring parameters via the Motion Manager

##### Saving parameters:

The configuration of a drive can be saved as a file for backup or for configuration of other drives.

 The Motion Manager allows the drive configuration to be uploaded via the object browser and saved as an XDC file (XML device configuration file).

##### Loading parameters to a drive:

The Motion Manager allows previously saved XDC files to be opened in the object browser, edited as necessary and downloaded to the drive.

 The save command allows the loaded parameter records to be permanently saved in the drive.

 When downloading XDC files, the following applies for the transfer to the drive:

- The CANopen message IDs contained in the XDC file (COB-IDs) are transferred. A copy of the drive can thereby be created.
- The node number contained in the XDC file is not transferred to the drive.
- If the download is to be used to create another drive in a system, but with a new node number (drive 2 configured the same as drive 1), the CANopen message IDs (COB-IDs) must subsequently be manually adapted in the object browser.
- For external controllers (MC 5010, MC 5005, MC 5004), the compensation values for the Hall signals contained in the XCD file are also transferred. This allows a controller to be exchanged without needing to re-teach the motor.

#### 4.12.2 Saving the parameter set in the drive

All or parts of the parameter set can be saved in the parameter memory of the Motion Controller by a write access to the object 0x1010.xx. They are thus available directly after the start.

- ▶ Write the "save" signature (0x65 0x76 0x61 0x73) to one of the following sub-indices of the object 0x1010 (see Communications manual):
  - .01: Saves all parameters
  - .02: Saves only the communication parameters
  - .03: Saves only the application parameters

## Configuring and starting the drive

### 4.12.3 Restore factory settings

The factory settings can be restored by a write access to object 0x1011. After a restore has been performed, at the next start of the controller the parameters have default values.

- ▶ Write the "load" signature (0x64 0x61 0x6F 0x6C) to one of the following sub-indices of the object 0x1011 (see Communications manual):
  - .01: Resets all parameters
  - .02: Resets only the communication parameters
  - .03: Resets only the application parameters
  - .04: Loads the most recently saved application parameters into the current application

### 4.12.4 Switching between different application parameter sets

Part of the controller parameters can be saved as parameter sets App1 and App2. The Reload command from object 0x1011 allows these two parameter sets to be exchanged dynamically.

#### Example

Switching the controller parameters of a gripper application between the operation with gripped item (App1) and without gripped item (App2).

#### Objects that can be stored in two parameter sets

Tab. 42: Load settings

Index	Subindex	Name	Type	Default value
0x2329	0x0A	Load Inertia / Load Mass	U32	–

Tab. 43: Speed controller

Index	Subindex	Name	Type	Default value
0x2344	0x01	Gain $K_p$	U32	a)
	0x02	Integral Time $T_N$	U16	a)
0x2345	0x01	Actual Velocity Filter $T_F$	U16	a)
0x2346	0x01	Setpoint Velocity Filter $T_F$	U16	a)
	0x02	Setpoint Filter Enable	U8	0
0x2347	0x01	Gain Factor $K_p$	U8	128
	0x02	Gain Factor $K_v$	U8	128

a) Motor-specific, is set by the motor selection wizard.

Tab. 44: Position controller

Index	Subindex	Name	Type	Default value
0x2348	0x01	Gain $K_v$	U8	a)

a) Motor-specific, is set by the motor selection wizard.

## Configuring and starting the drive

*Tab. 45: Settings for feedforward control*

Index	Subindex	Name	Type	Default value
0x2349	0x01	Current FeedForward Factor	U8	0
	0x02	Current FeedForward Delay	U16	0
0x234A	0x01	Velocity Feedforward Factor	U8	0
	0x02	Velocity FeedForward Delay	U16	0

*Tab. 46: General configuration*

Index	Subindex	Name	Type	Default value
0x234B	0x01	Display Motor Current Filter TF	U16	200
0x2350	0x00	Positive Torque Limit Homing	U16	1000
0x2351	0x00	Negative Torque Limit Homing	U16	1000
0x60E0	0x00	Positive Torque Limit Value	U16	6000
0x60E1	0x00	Negative Torque Limit Value	U16	6000

*Tab. 47: Configuration of the operating mode and of the speed profile*

Index	Subindex	Name	Type	Default value
0x6060	0x00	Modes of Operation	S8	0
0x6081	0x00	Profile Velocity	U32	32767
0x6083	0x00	Profile Acceleration	U32	30000
0x6084	0x00	Profile Deceleration	U32	30000
0x6086	0x00	Motion Profile Type	S16	0

## Selecting the operating mode

### 5 Selecting the operating mode

Motion Controllers of the V3.0 series can control the position, the speed, or the torque or force of a drive. The set-points can be specified in the following ways:

- Via a communications system by a master
- Local:
  - Using analog inputs
  - Via the PWM input
  - In Step mode via pulses
  - In Gearing mode via a quadrature signal

*Tab. 48: Overview of the operating modes and set-point specifications*

Control	The speed profile is calculated in the Motion Controller	The speed profile is calculated in the master	Analog set-point specification
Position	PP	CSP	APC
Speed	PV	CSV	AVC
Force/torque	–	CST	ATC
Reference run	Homing	–	–
Voltage output	–	Voltage Mode	Voltage Mode

The Modes of Operation parameter allows selection of the active drive profile. The current operating mode can be viewed in the Modes of Operation display.

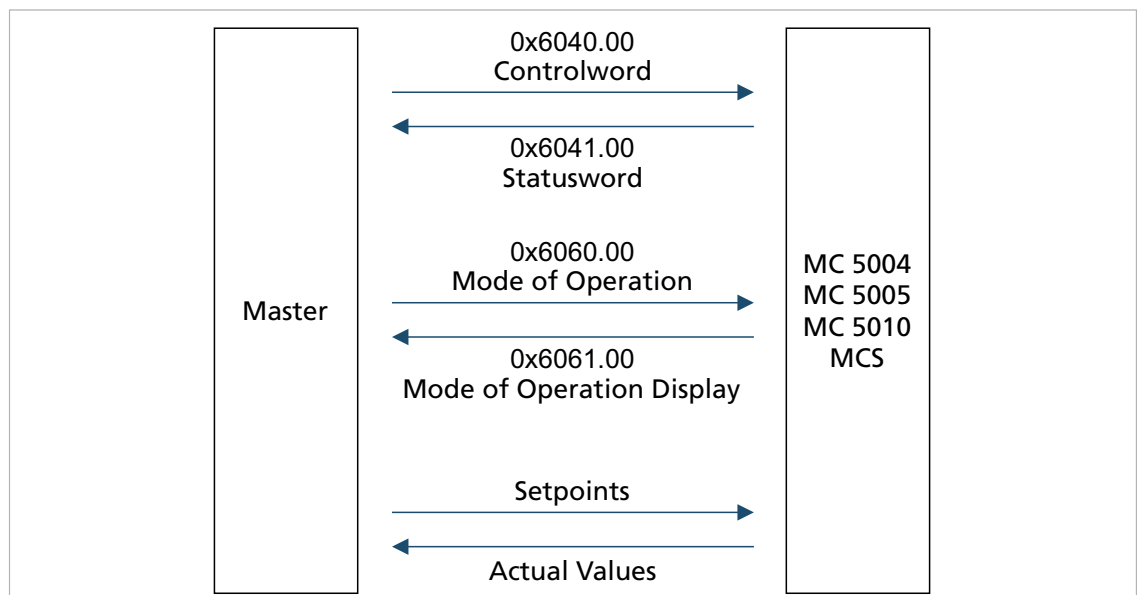

In addition, the movement is controlled via other bits in the controlword in the Profile Position and Homing operating modes.

## Selecting the operating mode

### Modes of Operation

Index	Subindex	Name	Type	Attr.	Default value	Meaning
0x6060	0x00	Modes of Operation	S8	rw	0	Select the operating mode -4: ATC -3: AVC -2: APC -1: Voltage mode 0: Controller not activated 1: PP 3: PV 6: Homing 8: CSP 9: CSV 10: CST

### Modes of Operation display

Index	Subindex	Name	Type	Attr.	Default value	Meaning
0x6061	0x00	Modes of Operation Display	S8	ro	–	Display of the selected operating mode

Overview of operating modes characteristics:





- Operating modes for position control:
  - Profile Position mode (PP): Position control where the target position is achieved via a speed profile.
  - Cyclic Synchronous Position mode (CSP): Position control with cyclically preset-point
  - Analog Position Control mode (APC): Position control with analog set-point specification
- Operating modes for speed control:
  - Profile Velocity mode (PV): Speed control where the target speed is achieved via a speed profile.
  - Cyclic Synchronous Velocity mode (CSV): Speed control with cyclically preset-point
  - Analog Velocity Control mode (AVC): Speed control with analog set-point specification
- Operating modes for torque control
  - Cyclic Synchronous Torque mode (CST): Torque control with cyclically specified set-point
  - Analog Torque Control mode (ATC): Torque control with analog set-point specification
- Operating modes for referencing:
  - Homing mode: Operating mode for referencing the drive position
- Operating mode with direct voltage output
  - Voltage mode: Direct output of the voltage at the motor, specified either via the communications system or via an analog input.

## Selecting the operating mode

### 5.1 Starting and switching operating modes

**i** Additional configuration steps are required for FAULHABER products with safety option.

#### Initial start of the operating modes

The state machine is already in the Operation Enabled state		The state machine is not in the Operation Enabled state.	
			
		The operating mode can be selected. The control does not yet start.	
			
Control is started as soon as the operating mode is selected.		Once the state machine is set to the Operation Enabled state, control starts immediately.	
			
APC, AVC, ATC and Voltage mode	The set-point is immediately taken from the set source.		
CSP, CSV, and CST	Either 0 (CST and CSV) or the current position (CSP) is specified as the initial set-point. No set-point is loaded until the operating mode has been switched.		
PP and PV	Either 0 (PV) or the current position (PP) is specified as the initial set-point. No set-point is loaded until the operating mode has been switched.		

#### Initial set-points when changing the operating mode

Control	The speed profile is calculated by the Motion Controller	The speed profile is calculated by the master	Analog set-point specification
Position	Current position	Current position	<ul style="list-style-type: none"> <li>▪ Gearing and Step mode: current position</li> <li>▪ Analog input: analog set-point</li> </ul>
Speed	$n^* = 0$	$n^* = 0$	Analog set-point
Force/torque	$T^* = 0$	$T^* = 0$	Analog set-point
Reference run	$n^* = 0$	–	–
Voltage output	–	0 V	Analog set-point

## Selecting the operating mode

### Behavior when changing the operating mode

The behavior when starting an operating mode can be configured using the *Set Point Reset on Change of Operation Mode* bit in the Operation Mode Options (0x233F).

Index	Subindex	Name	Type	Attr.	Default value	Meaning
0x233F	0x00	OpMode Options	U16	rw	0x0001	Bit-coded

Bit 0 - *Set Point Reset on Change of Operation Mode*:

- 0: Set-points are not reset by changing the operating mode. In particular in operating modes with cyclical set-point (CSx) the last set-point received will be used directly for control. In the operating modes PP and PV the change into the operating mode does not occur until after the change to the first new set-point has been written.
- 1: Set-points are reset by changing the operating mode.
  - For CST: Torque set-point = 0
  - For CSV, PV: Speed set-point = 0
  - For CSP, PP: Position set-point = Actual position

Bit 1 - Use position limits as limits in speed mode:

- 0: The position limits from 0x607D merely limit the position set-point in the object 0x607A.
- 1: In Velocity and Torque modes, the position limits from 0x607D are handled as limit switches. If a limit is reached, the drive stops.

Bit 2 - *Auto Enable Power Stage*:

- 0: After the start of the controller, the CiA 402 state machine is in the *Switch On Disabled* state.
- 1: After starting the controller, the drive attempts to switch the controller directly into the *Operation Enabled* state. That status enables the operating modes APC, AVC and ATC to be activated, even without any direct intervention by a sequence program or higher-level control system.

Bit 3 - *Immediate References are Relative to Actual Position*:

- 0: Relative position set-points (movement commands) are added to the last received set-point, even if they carry the "immediate" flag.
- 1: Relative movement commands are added to the current position, if they are labelled with the "immediate" flag.

Bit 4 - *Ignore Position Limits during homing*:

- 0: The current software position limits are also taken into account as limits during a reference run if bit 1 is set.
- 1: During a reference run, the current software position limits are ignored.

Bit 5 - *Use homing torque limits during homing*:

- 0: During a reference run, the torques currently set in the torque limits or the limit values configured for the motor are used as limits.
- 1: During a reference run, the limit values set in objects 0x2350.00 and 0x2351.00 are used. The limit torque can thereby be set in a targeted manner, particularly for referencing via a block.

## Selecting the operating mode

### 5.2 Profile Position mode (PP)

#### 5.2.1 Basic function

In the Profile Position mode (PP), the Motion Controller controls the position of the drive. The set-point is specified via object 0x607A by the master or via a local sequence program. The settings for the speed profile are taken in to account. Scaling of the set-points and actual values via the factor group is always taken into account.

A new movement task is started via a rising edge in bit 4 of the controlword.

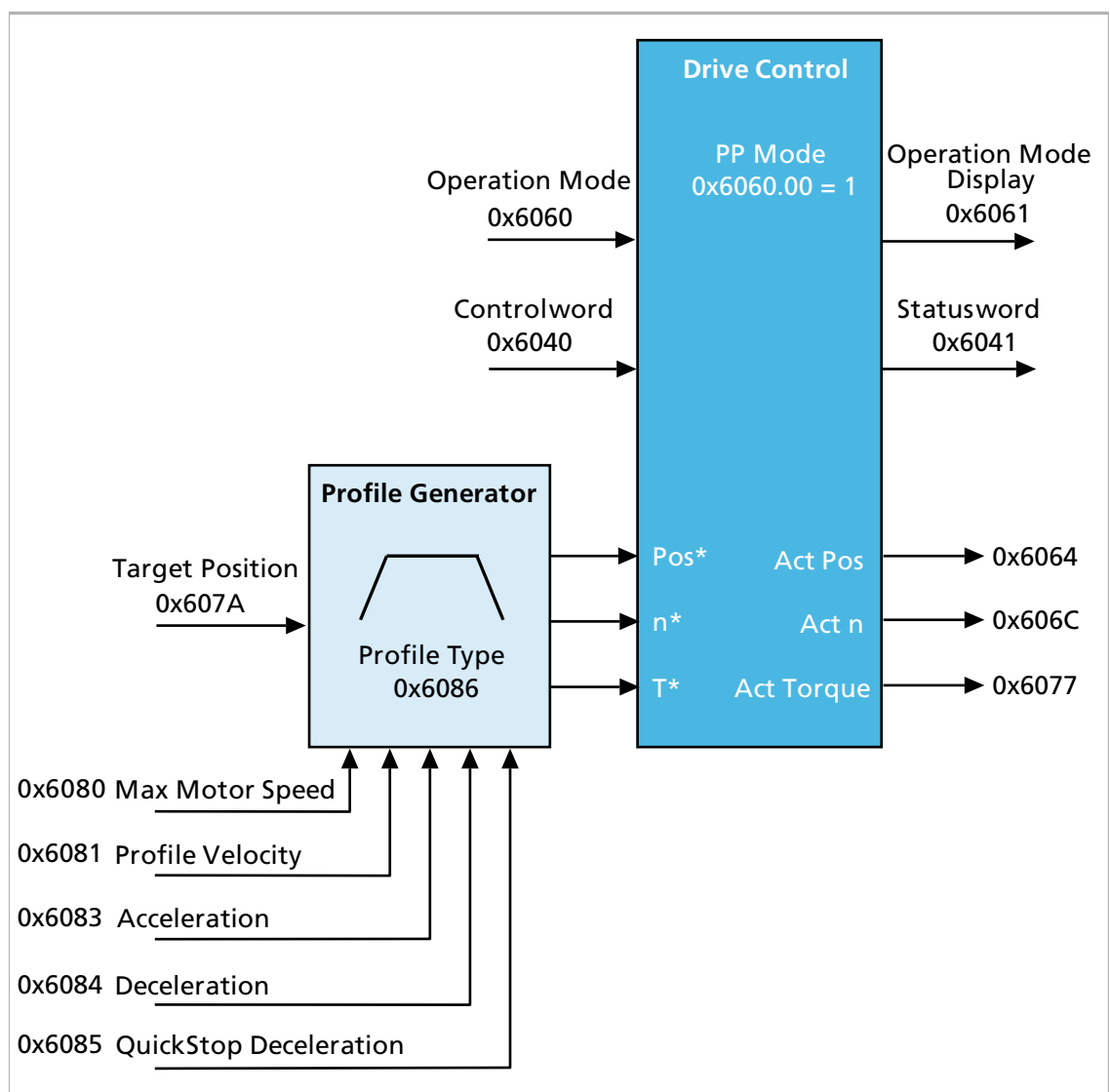

Fig. 25: Overview of Profile Position mode

The position set-point can be specified in two different ways:

- Absolute set-point: direct specification of the target value for the position
- Relative set-point: specification of a distance that the drive is to move



## Selecting the operating mode

### Starting a movement task

1. A movement task is started via a rising edge in bit 4 of the controlword.
2. The internal profile generator generates a complete speed profile from the then actual profile parameters and the target position.
3. The set-point for the control is specified incrementally according to this profile via the demand values.
4. The pre-control values for the speed and torque, which are likewise present in the profile, can optionally be activated on the control. It is thereby possible to, e.g., considerably reduce the following error.
5. If the target position was reached, the target is reported as reached in the statusword after the Position Window Time (0x6068) elapses.

### Options for the set-point specification

Option	Description
Change Set Immediate	It is then possible to select whether a newly passed set-point is to be moved to immediately (even during active positioning) or whether the previous movement task is to first be finished. Up to three set-points can be specified as <i>Set of Setpoints</i> while the first movement task is still being processed.
Change on set-point	In the standard case, a target position is moved to. The drive stops. Only then is a new target position moved to. With the <i>Change On Setpoint</i> option, the drive is not braked upon reaching the target. As soon as the first target is reached at the running speed, the next movement task is moved to while in motion, but with changed profile parameters if necessary.
Halt	A running movement task can be interrupted. As soon as the halt signal is retracted, the originally specified position is moved to.

### Effective sub-functions

- Set-point specification via the profile generator
- Control of the position via the controller according to chap. 4.3, p. 25
- Measurement of the actual values
- Monitoring of the movement for slippage and following error
- Optional: Torque and speed limitation
- Estimate of the motor temperature and output stage temperature as a protective function
- Monitoring of the movement range via the Software Position Limits and limit switches

## Selecting the operating mode

### 5.2.2 Statusword/Controlword Profile Position mode

Operating mode-specific bits are used in the controlword and statusword for the Profile Position operating mode.

**i** If no positioning is being performed, setting bit 4 from 0 to 1 will start the positioning of the axes. If positioning is taking place at the moment, the drive behaves in accordance with Tab. 50.

Tab. 49: Operating mode-specific bits of the controlword (Profile Position mode)

Bit	Function	Description
4	New set-point	0: Do not start positioning. 1: See Tab. 50.
5	Change set immediately	0: Movement towards the new position does not start until the preceding positioning task has been completed. 1: Movement towards the new position starts immediately. New set-points overwrite the old set-point.
6	Abs/Rel	0: Position set-point is an absolute value. 1: Position set-point is a relative value.
9	Change on set-point	0: A new movement task is not loaded until the drive has reached its previous target position. 1: The drive brakes or accelerates to the velocity profile of the next set-point. Movement towards the new set-point starts without any preceding stop.

Tab. 50: Meaning of bits 4, 5, 9 in the controlword

Bit 9	Bit 5	Bit 4	Meaning
0	0	0 → 1	Movement towards the new position does not start until the preceding positioning task has been completed (Target Reached).
x	1	0 → 1	Move towards the new position immediately.
1	0	0 → 1	The current movement is maintained. If the previous target position had already been reached, the drive switches immediately to the next set-point as defined by the speed profile.

1 = Bit set  
 0 = Bit not set  
 0 → 1 = Rising edge of the bit  
 X = Bit not used (state irrelevant)

Tab. 51: Operating mode-specific bits of the statusword (profile position mode)

Bit	Function	Description
10	Target Reached	0: Stop (bit 8 in the controlword) = 0: Target position not reached. 0: Stop (bit 8 in the controlword) = 1: Drive brakes to a stop. 1: Stop (bit 8 in the controlword) = 0: Target position reached. 1: Stop (bit 8 in the controlword) = 1: Drive is at a standstill.
12	Set-point acknowledged	0: Previous set-point being changed or already reached. 1: New set-point has been loaded.
13	FollowingError	0: The actual position follows the instructions without a following error. 1: Permissible range for the following error exceeded.

Information on using a set of set-points can be found in chap. 5.2.4, p. 100.

## Selecting the operating mode

### 5.2.3 Control structure for position controller

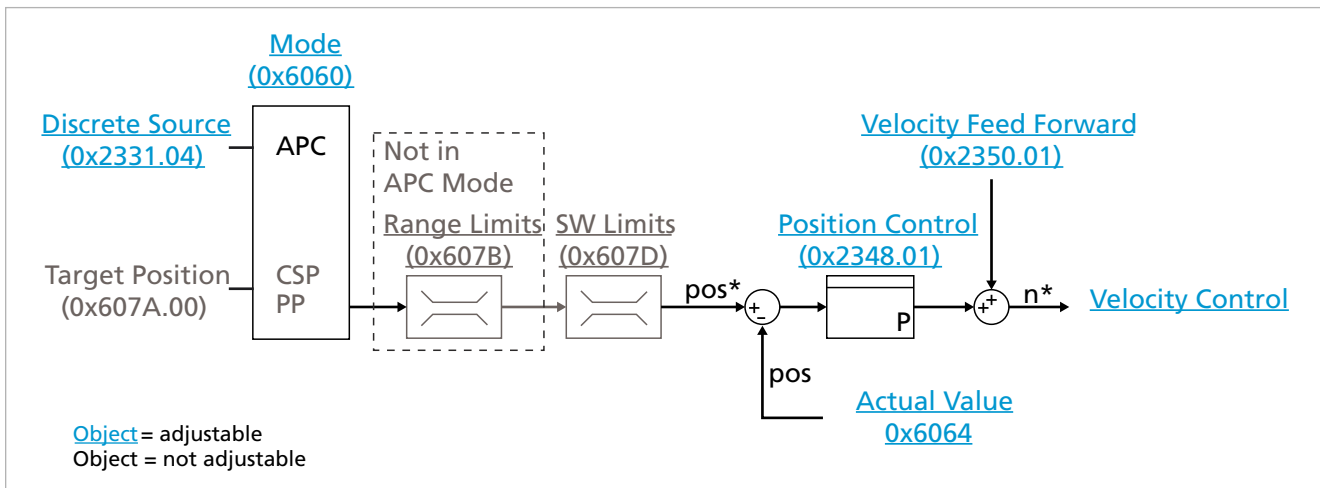

Fig. 26: Motion Manager view of Profile Position mode

#### Procedure for Profile Position mode

- ✓ Controller parameters are set acc. to chap. 4.3, p. 25
- ✓ Parameters for movement monitoring (Position Window, Following Error Window) are adapted to the application
- ✓ Operating mode is selected via  $0x6060.00 = 1$
- ✓ Control is activated (the drive is in the *Operation Enabled* state)
  1. Set profile parameters according to chap. 4.4, p. 43.
  2. Write the target position in  $0x607A.00$ .
  3. Start positioning via the rising edge in bit 4 of the controlword. Also set the optional bits here.
- ↩ The drive confirms the target position in the statusword via the set-point acknowledged (bit 12) and starts the movement task. If the target was reached, this is reported via the target reached bit (bit 10) in the statusword.

#### Options

The control deviation between set position and actual position (following error) can be reduced by operating the drive with a speed profile that has been adapted to the mechanics and activated feedforward control.

## Selecting the operating mode

### 5.2.4 Combined speed profiles

In Profile Position operating mode, profile segments can be combined with each other. This allows multiple set-points with different profile parameters to be loaded successively to the Motion Controller. The following options can be selected, using the operating mode-specific bits in the Controlword 0x6040:

- Send set-points one after another as individual movement tasks.
- Immediately activate a new set-point with new profile parameters.
- Activate a new set-point with new profile parameters when the preceding set-point has been reached, without stopping the movement.

*Tab. 52: Coding of the Controlword 0x6040 and behavior of the drive when a new position set-point is applied*

Bit	Function	Meaning
Bit 4	New set-point	The set-point including the profile parameters is loaded at the rising edge of bit 4.
Bit 5	Change set immediately	Load the set-point immediately or after the end of a current movement task: Bit 5 = 1: Movement towards the position starts immediately. Bit 5 = 0: Movement towards the new position does not start until the preceding positioning task has been completed.
Bit 6	Abs/Rel	Positions can be specified as absolute or relative set-points. If bit 6 is set at the rising edge of bit 4, the set-point is interpreted as relative.
Bit 9	Change on set-point	Change on the following movement task after a previous standstill or during operation. Bit 9 = 0: The new movement task is not applied until the drive has reached its previous target position. Bit 9 = 1: When reaching the previous target position, the drive does not brake. The new movement task is activated as the drive continues through the preceding target.

**i** The Controlword 0x6040 is set by the higher-level control. The Statusword (0x6041) is the response of the drive and is set by the drive. The relevant bits in the statusword are:

- Bit 10: Target Reached
- Bit 12: Set-point acknowledged

## Selecting the operating mode

### 5.2.4.1 Specifying a single position set-point

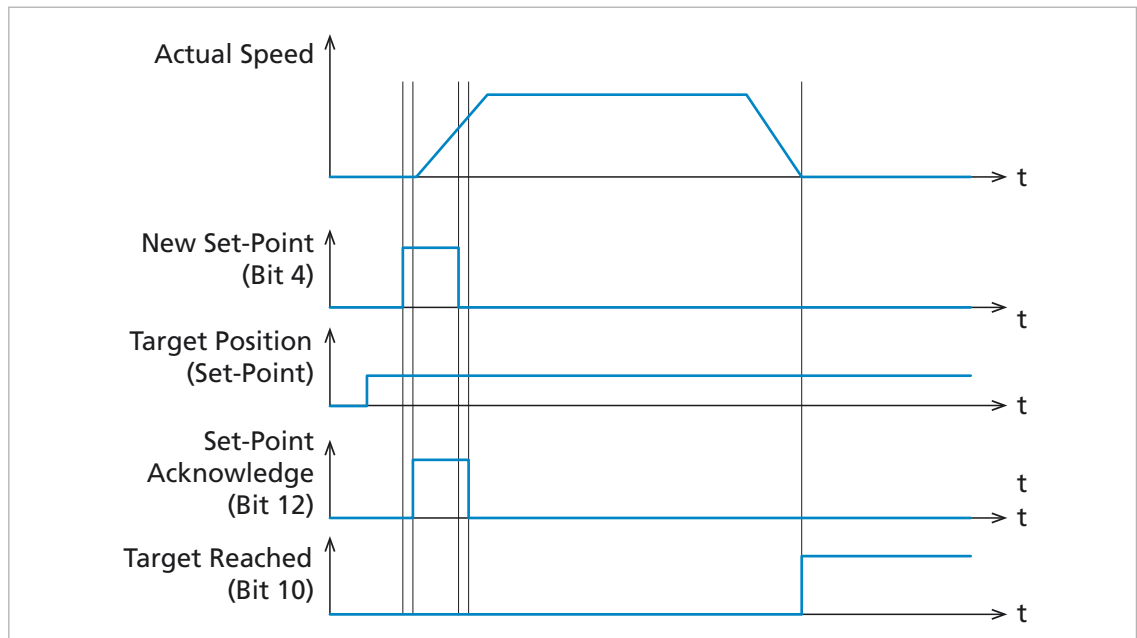

Fig. 27: Behavior of the drive when setting a set-point

- In PP operating mode a new target position is not loaded until the rising edge of bit 4 in the controlword (new set-point). To achieve this, the higher-level control sets bit 4, after the new set-point is written to the object 0x607A.
- i** If during operation via CANopen the controlword and the target position are loaded together in PDO, firstly the new set-point is written to the object 0x607A and then the controlword is evaluated.
- The drive checks whether the new set-point can be processed. The drive signals the loading of a set-point via bit 12 (Set-point acknowledge) = 1 in the statusword. Only then the higher-level control may reset the New set-point bit in the controlword. If the drive can make an advance note of further set-points, bit 12 of the statusword (Set-point acknowledge) is reset to 0.
- If after the set-point has been reached no further set-points have been communicated to the drive, bit 10 of the statusword (Target Reached) is set to 1.

## Selecting the operating mode

### 5.2.4.2 Specifying multiple set-points in succession (Set of set-points)

Whilst the first set-point is being processed (with the drive still running, i.e. Target Reached has not yet been signaled), further set-points can already be loaded. Bit 4 (New set-point) in the controlword and bit 12 (Set-point acknowledge) in the statusword are set to allow further set-points to be loaded to the drive.

If the value 0 is set in bit 5 of the controlword (Change set immediately), movement towards the new set-point does not start until the preceding set-point has been reached.

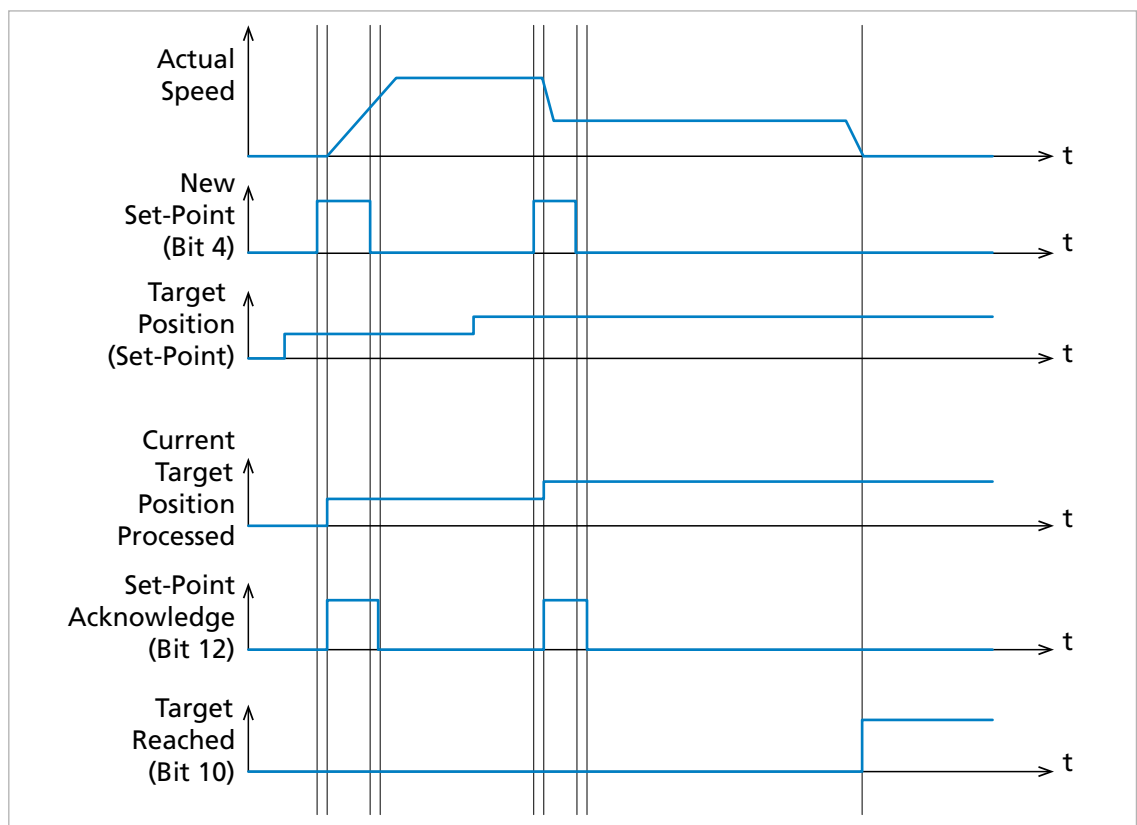

Fig. 28: Handshaking procedure for a succession of set-points, each set-point is loaded immediately

- In PP operating mode a new target position is not loaded until the rising edge of bit 4 in the controlword (new set-point). To achieve this, the higher-level control sets bit 4, after the new set-point is written to the object 0x607A.
- i** If during operation via CANopen the controlword and the target position are loaded together in PDO, firstly the new set-point is written to the object 0x607A and then the controlword is evaluated.
- The drive checks whether the new set-point can be processed. The drive signals the loading of a set-point via bit 12 (Set-point acknowledge) = 1 in the statusword. Only then the higher-level control may reset the New set-point bit in the controlword. If the drive can make an advance note of further set-points, bit 12 of the statusword (Set-point acknowledge) is reset to 0.

## Selecting the operating mode

---

- If a set-point is set and a further set-point is to be transferred to the drive, two types of response behavior are available depending on the setting of bit 5 of the controlword (Change set immediately):
    - Change set immediately = 1: Movement towards the new set-point starts immediately.
    - Change set immediately = 0: Movement towards the new set-point does not start until the preceding set-point has been reached. The drive stops briefly in between the two movements until it recognizes that the first target has been reached (see chap. 5.2.4.3, p. 104).
  - If after the set-point has been reached no further set-points have been communicated to the drive, bit 10 of the statusword (Target Reached) is set to the value 1.
- i** In the example shown (see Fig. 28), new instructions for the acceleration or the speed were communicated with the new set-point; this is evidenced by the change of the velocity profile (Actual Speed).

## Selecting the operating mode

### 5.2.4.3 Specifying multiple position set-points with direct transition (Change on set-point)

If the value 0 is set in bit 5 of the controlword (Change set immediately), movement towards the new set-point does not start until the preceding set-point has been reached.

If bit 9 (Change on set-point) = 0, the drive stops between the two set-points before the next movement task is being processed. If on the other hand the Change on set-point bit is set, the change to the new profile parameters proceeds without stopping as soon as the preceding set-point has been achieved. The specification of set-points with a change on set-point bit setting is thus particularly suitable for continuous positioning movements with continuously changing profile parameters such as for 2-axis operation when milling or for a 3D printer.

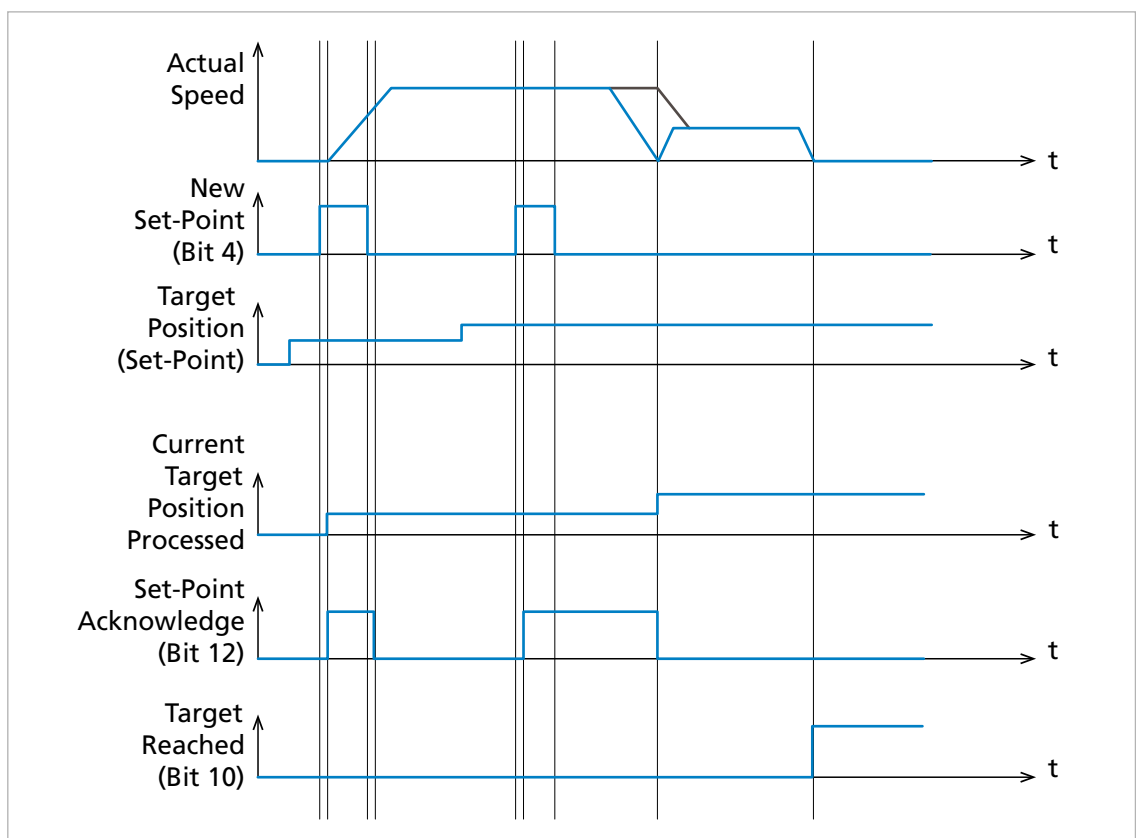

Fig. 29: Handshaking procedure for the set of set-point method

- In PP operating mode a new target position is not loaded until the rising edge of bit 4 in the controlword (new set-point). To achieve this, the higher-level control sets bit 4, after the new set-point is written to the object 0x607A.
- i** If during operation via CANopen the controlword and the target position are loaded together in PDO, firstly the new set-point is written to the object 0x607A and then the controlword is evaluated.
- The drive checks whether the new set-point can be processed. The drive signals the loading of a set-point via bit 12 (Set-point acknowledge) = 1 in the statusword. Only then the higher-level control may reset the New set-point bit in the controlword. If the drive can make an advance note of further set-points, bit 12 of the statusword (Set-point acknowledge) is reset to 0.



## Selecting the operating mode

---

- If during movement towards the first set-point a further set-point is sent to the drive (Immediate bit = 0), this will be noted in advance. The drive will move towards this set-point only once the first set-point has been reached.
- Bit 9 of the controlword (Change on set-point) controls the dynamic behavior during the transition from one set-point to another set-point (see Fig. 29):
  - Change on set-point = 0: The drive stops at the set-point. Then it proceeds towards the new set-point.
  - Change on set-point = 1: The drive brakes or accelerates to the velocity profile of the next set-point. Movement towards the new set-point starts without any preceding stop.
- If after the set-point has been reached no further set-points have been communicated to the drive, bit 10 of the statusword (Target Reached) is set to the value 1.

## Selecting the operating mode

### 5.2.5 Examples

#### 5.2.5.1 Example: Specification of multiple position set-points

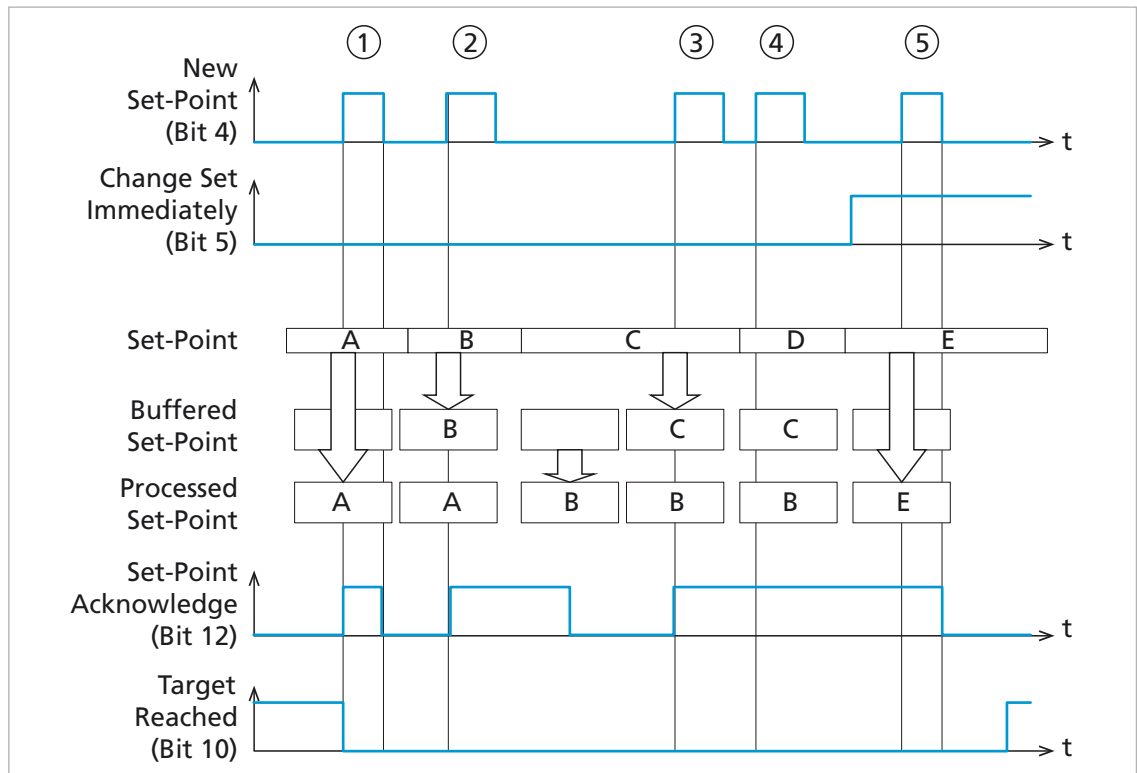

Fig. 30: Transfer of multiple set-points for a drive with a maximum of 2 set-point memory slots

- ① Set-point A is communicated to the drive. Bit 12 in the statusword (Set-point acknowledge) is initially set from 0 to 1. Since the drive can still accept further set-points, bit 12 in the statusword (Set-point acknowledge) is then reset again from 1 to 0 as soon as the New set-point bit in the controlword is reset.
- ② Set-point B is communicated to the drive. Bit 12 in the statusword (Set-point acknowledge) is initially set from 0 to 1. Since the drive cannot accept any further set-points, bit 12 in the statusword (Set-point acknowledge) is not reset from 1 to 0 until set-point A has been reached.
- ③ Set-point C is communicated to the drive. Bit 12 in the statusword (Set-point acknowledge) is set from 0 to 1. Since the drive cannot accept any further set-points, bit 12 in the statusword (Set-point acknowledge) is not reset from 1 to 0.
- ④ Set-point D is communicated to the drive. Since set-point C is still flagged in the buffer, the drive cannot accept any further set-points. Bit 12 in the statusword (Set-point acknowledge) remains unchanged at 1.
- ⑤ Set-point E is communicated to the drive. Bit 5 of the controlword (Change set immediately) was previously set from 0 to 1. The drive immediately moves towards set-point E. All previous set-points are discarded.

**i** In addition to the target position being executed, FAULHABER Motion Controllers have the capacity to store a maximum of two further set-points.

## Selecting the operating mode

### 5.2.5.2 Example: Positioning with absolute set-points, followed by reversing

The drive is to move to the position 12,000 increments. After a brief waiting time, it is to return back to position 0. The acceleration and the deceleration are to be 1000 1/s<sup>2</sup>.

- ✓ The state machine is in the *Operation Enabled* state.
- ✓ The actual position must be zeroed by means of a reference run.
- ✓ The software position ranges and software range limits must lie outside the range 0 ... 12,000.

1. Select the PP operating mode:

- In the object 0x6060.00, set the value **01**.

2. Set the set-point and profile parameters:

- In the object 0x607A.00, set the value **12000**.
- In the object 0x6083.00, set the value **1000**.
- In the object 0x6084.00, set the value **1000**.

3. Mark the set-point as an absolute set-point, and start the movement command:

- In the object 0x6040, set the value **0x00 1F**.

The drive will acknowledge the set-point as accepted via bit 12 (0x6041 = 0x1027).

4. Reset the start bit again in the controlword.

- In the object 0x6040, set the value **0x00 0F**.

The drive confirms its readiness to accept further set-points by resetting the Set-point acknowledge bits (0x6041 = 0x0027).

The drive moves to the target position and, after the Position window time has elapsed, signals in bit 10 (0x6041.00 = 0x0427) that the target position has been reached.

The drive is moved by 12,000 increments.

5. Reset the set-point for the return movement.

- In the object 0x607A.00, set the value **00 00 00 00**.

6. Repeat steps 3 and 4.

- ↩ The drive is moved to the position 12,000 increments and then moved back again.



When operating a master control via a fieldbus, the feedback of the Motion Controller in the statusword must also be evaluated before the next step is performed.

## Selecting the operating mode

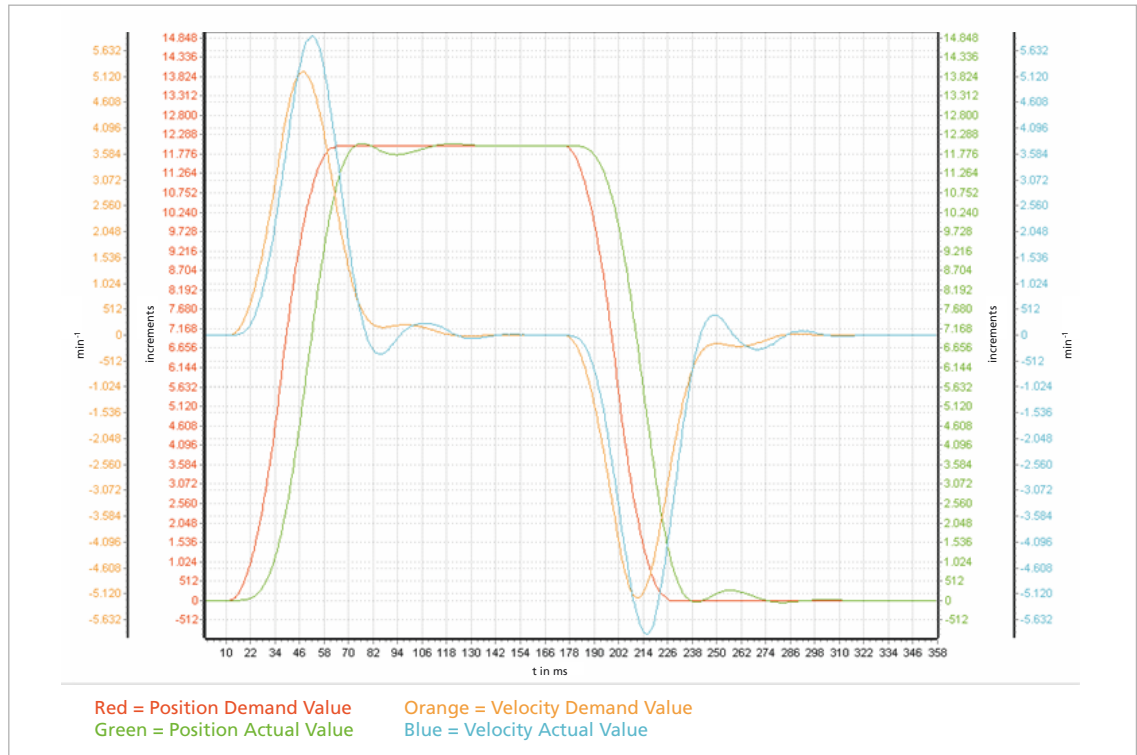

Fig. 31: Speed profile of a positioning operation with absolute set-points, followed by reversing

### 5.2.5.3 Example: Positioning with relative set-points, followed by reversing

A drive shall be moved by 12,000 increments relative to the current position.

To avoid oscillations at the elastically coupled mechanism, reduced acceleration is employed, and in addition the Sin<sup>2</sup> velocity profile is selected. Acceleration and deceleration are to be 100 1/s<sup>2</sup>.

- ✓ The state machine is in the *Operation Enabled* state.
  - ✓ The software position ranges must lie outside the range of 0 ... 12,000 around the current position.
1. Select the PP operating mode:
    - In the object 0x6060.00, set the value **01**.
  2. Set the set-point and profile parameters:
    - In the object 0x607A.00, set the value **12000**.
    - In the object 0x6083.00, set the value **100**.
    - In the object 0x6084.00, set the value **100**.
    - In the object 0x6086.00, set the value **1**.
  3. Mark the set-point as a relative set-point and start the movement command:
    - In the object 0x6040, set the value **0x00 5F**.

The drive will acknowledge the set-point as accepted via bit 12 (0x6041 = 0x1027).

## Selecting the operating mode

4. Reset the start bit again in the controlword.
  - In the object 0x6040, set the value **0x00 0F**.

The drive confirms its readiness to accept further set-points by resetting the Set-point acknowledge bits (0x604 = 0x0027).

The drive moves to the target position and, after the Position window time has elapsed, signals in bit 10 (0x6041.00 = 0x0427) that the target position has been reached.

The drive is now in the position +12,000 increments relative to the start position.

5. Reset the set-point for the return movement.
  - In the object 0x607A.00, set the value -12000.
6. Repeat steps 3 and 4.

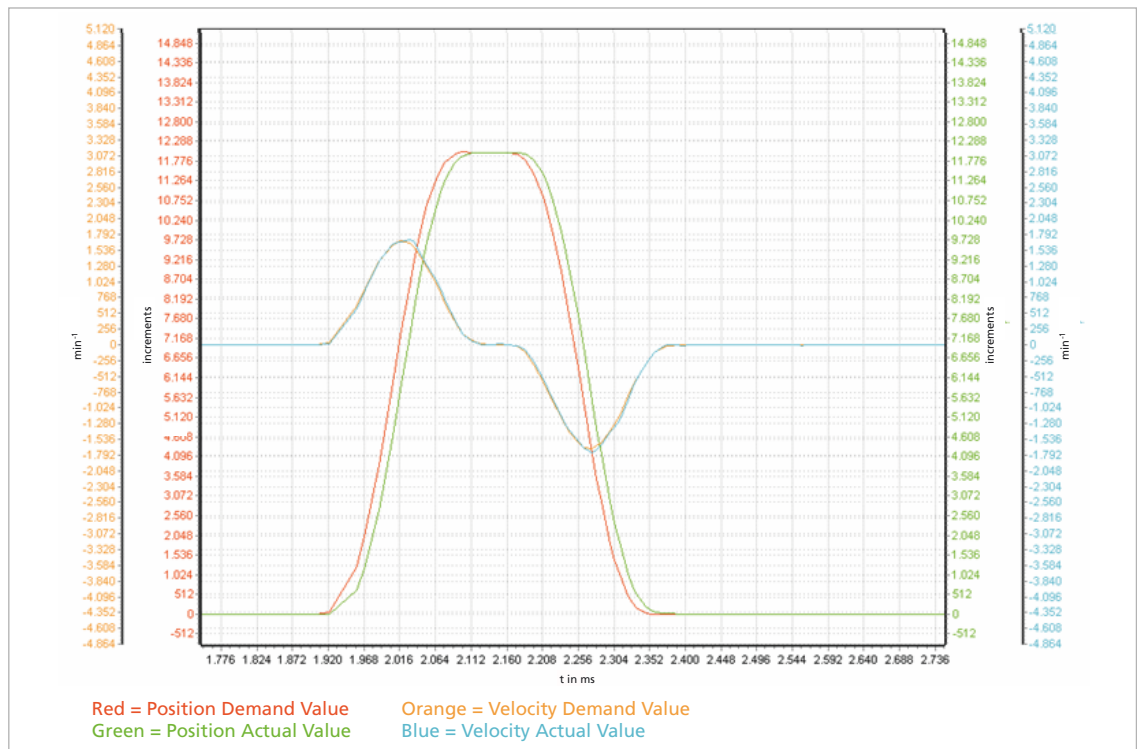

Fig. 32: Speed profile of a positioning operation with relative set-points, followed by reversing

## Selecting the operating mode

### 5.2.5.4 Example: Combined movement

One axis is to move to the position 32,678 increments. After this it is to move immediately to the position 34,816. Finally it is to move back to the position 0.

To avoid oscillations at the elastically coupled mechanism, reduced acceleration is employed, and in addition the Sin<sup>2</sup> velocity profile is selected.

- ✓ The state machine is in the *Operation Enabled* state.
- ✓ The actual position must be zeroed by means of a reference run.
- ✓ Software Position Ranges and Software Range Limits lie outside of the range 0 ... 34816.

1. Select the PP operating mode:

- In the object 0x6060.00, set the value **01**.

2. Set the set-point and profile parameters:

- In the object 0x607A.00, set the value **32678**.
- In the object 0x6083.00, set the value **100**.
- In the object 0x6084.00, set the value **100**.
- In the object 0x6086.00, set the value **1**.

3. Adjust the Position Window Time to the application:

- In the object 0x6068.00, set the value **100**.

4. Mark the set-point as an absolute set-point, and start the movement command:

- In the object 0x6040, set the value **0x00 1F**.

The drive acknowledges the set-point as accepted via bit 12 (0x6041 = 0x1027)

The drive starts with the first movement command.

5. Reset the start bit again in the Controlword.

- In the object 0x6040, set the value **0x00 0F**.

The drive confirms its readiness to accept further set-points by resetting the Set-point acknowledge bits (0x6041 = 0x0027).

6. Write and activate the second set-point:

- In the object 0x607A.00, set the value **34816**.
- In the object 0x6040.00, set the value **0x00 1F**.

The drive acknowledges the set-point as accepted via bit 12 (0x6041 = 0x1027)

7. Reset the start bit again in the Controlword.

- In the object 0x6040, set the value **0x00 0F**.

The drive confirms its readiness to accept further set-points by resetting the Set-point acknowledge bits (0x6041 = 0x0027).

## Selecting the operating mode

8. Write and activate the third set-point.
  - In the object 0x607A.00, set the value 0.
  - In the object 0x6040.00, set the value 0x00 1F.

The drive acknowledges the set-point as accepted via bit 12 (0x6041 = 0x1027)

9. Reset the start bit again in the Controlword.
  - In the object 0x6040, set the value 0x00 0F.

By failing to reset the Set Point Acknowledge Bit (bit 12), the drive signals that it cannot accept any further set-points.

The first target is now reached. The drive starts to perform the 2nd movement command. This releases a set-point buffer. The drive confirms its readiness to accept further set-points by resetting the Set Point Acknowledge Bit (0x6041 = 0x0027). Since there are still further set-points outstanding, the target is flagged as not yet reached.

The second target is now reached. The drive starts to perform the 3rd movement command. The drive moves to the target position and, after the Position Window Time has elapsed, signals in bit 10 (0x6041.00 = 0x0427) that the target position has been reached.

↩ The drive is now once again at the 0 increments position.

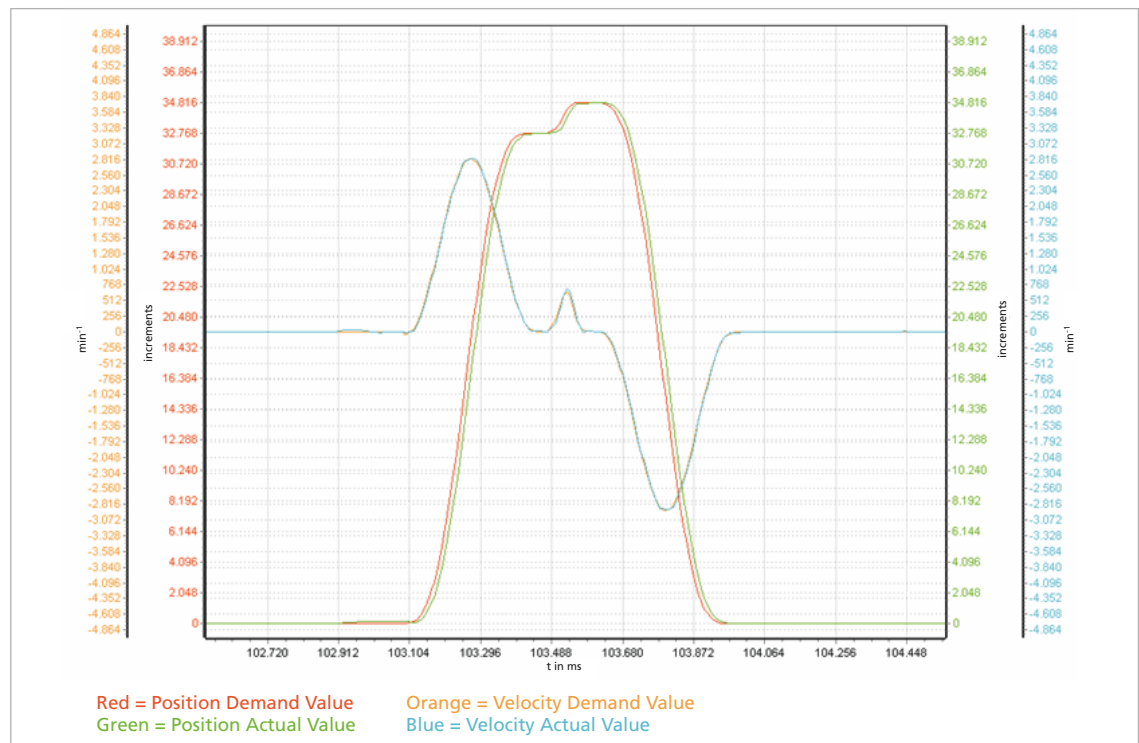

Fig. 33: Speed profile of a positioning operation with multiple absolute set-points, followed by reversing

## Selecting the operating mode

### 5.3 Profile Velocity mode (PV)

#### 5.3.1 Basic function

In the Profile Velocity mode (PV), the Motion Controller controls the speed of the drive. The set-point is specified via object 0x60FF by the master or via a local sequence program. Scaling of the set-points and actual values via the factor group is always taken into account.

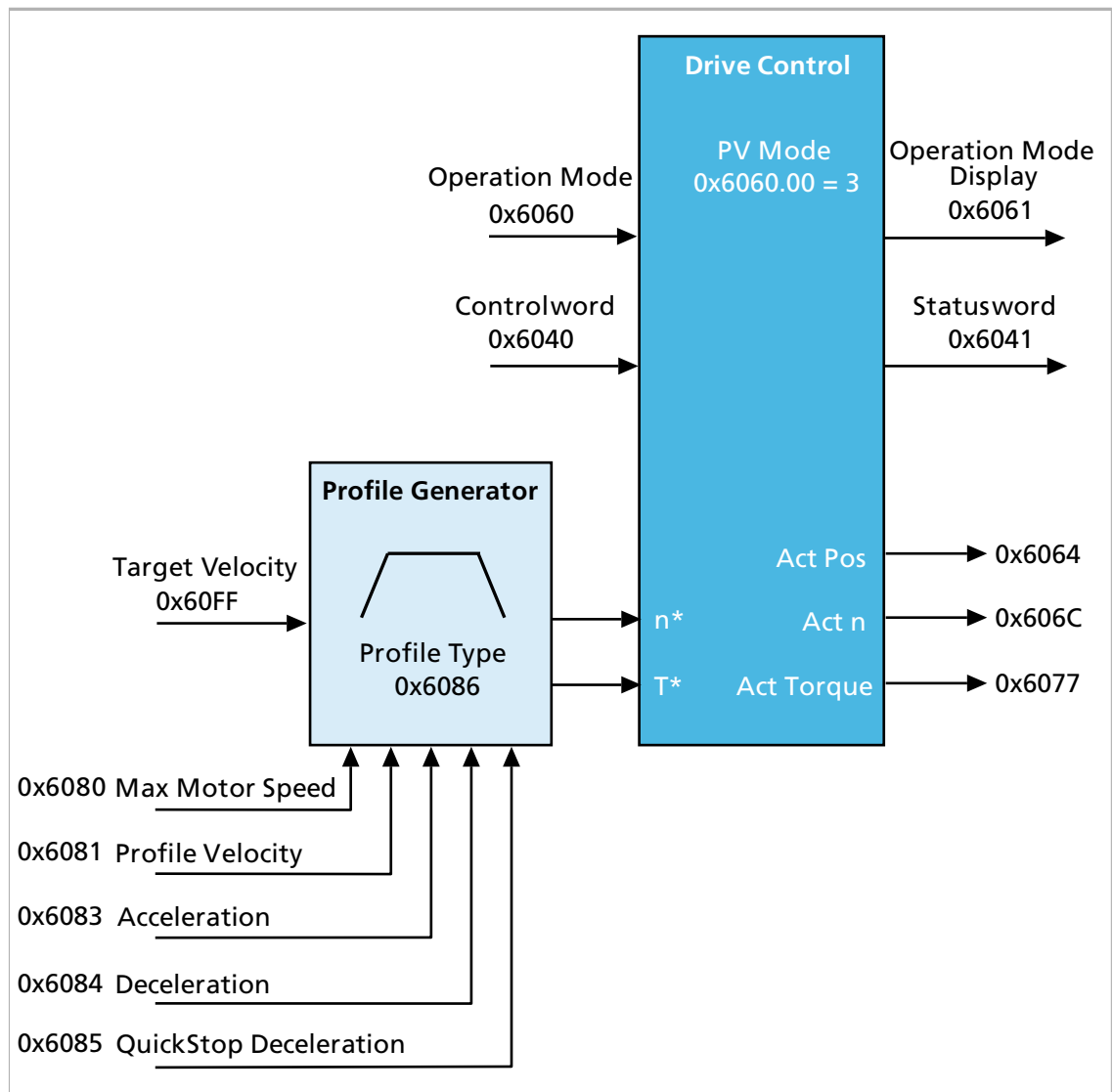

Fig. 34: Overview of Profile Velocity mode



## Selecting the operating mode

### Set-point specification and operation

- If the output stage is activated, new set-points are applied immediately. The current profile parameters are taken into account for each new set-point.
- Using the set-point, the profile generator generates appropriate demand values for the control.
- The existing pre-control value for the torque, which is likewise present in the profile, can optionally be activated for the control.
- If the target speed was reached, the speed is reported as reached in the statusword after the Velocity Window Time (0x606E) has elapsed.
- In addition, the standstill of the drive is monitored via the Velocity Threshold Window and is also reported back in the statusword.

### Effective sub-functions

- Set-point specification via the profile generator
- Control of the speed via the controller according to chap. 4.3, p. 25.
- Measurement of the actual values
- Monitoring of the movement for slippage
- Optional: Torque and motor speed limitation
- Estimate of the motor temperature and output stage temperature as a protective function
- Optional: Monitoring of the movement range via the Software Position Limits and limit switches

### 5.3.2 Statusword/Controlword Profile Velocity mode

Operating mode-specific bits are used in the statusword for the Profile Velocity operating mode.

*Tab. 53: Operating mode-specific bits of the statusword (profile velocity mode)*

Bit	Function	Description
10	Target Reached	0: Stop (bit 8 in the controlword) = 0: Target Velocity not reached 0: Stop (bit 8 in the controlword) = 1: Drive brakes to a stop 1: Stop (bit 8 in the controlword) = 0: Target Velocity reached 1: Stop (bit 8 in the controlword) = 1: Drive is at a standstill
12	n = 0	0: Drive is in motion 1: Drive is at a standstill
13	Maximum Slippage Error	0: Maximum permitted speed deviation not reached 1: Maximum permitted deviation between set and actual speed reached.

In the controlword the Profile Velocity operating mode does not use any operating mode-specific bits.

## Selecting the operating mode

### 5.3.3 Controller structure for speed controller

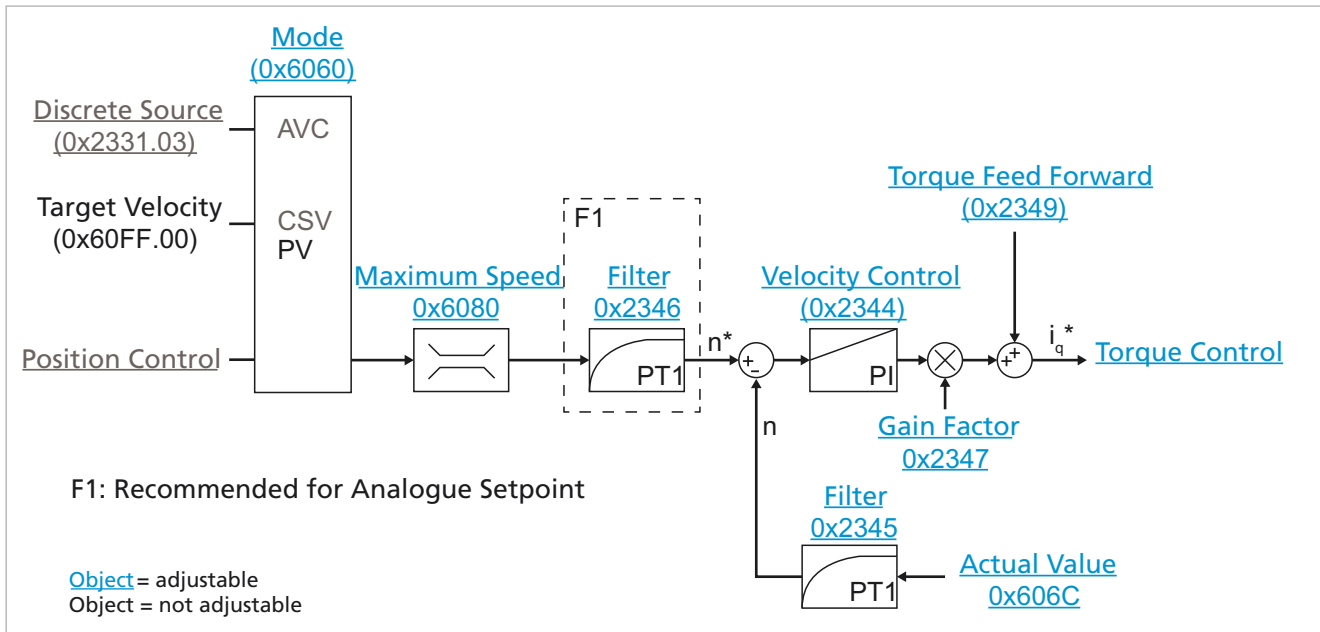

Fig. 35: Motion Manager view of the Profile Velocity mode

#### Procedure for Profile Velocity mode

- ✓ Controller parameters are set acc. to chap. 4.3, p. 25
- ✓ Parameters for movement monitoring (Velocity Window, Velocity Threshold Window) are adapted to the application
- ✓ Operating mode is selected via  $0x6060.00 = 3$
- ✓ Control is activated (the drive is in the *Operation Enabled* state)
  1. Set profile parameters according to chap. 4.4, p. 43.
  2. Write set-point in  $0x60FF.00$ .
- ↩ The drive immediately accelerates to the specified target speed. If the target was reached, this is reported via the target reached bit (bit 10) in the statusword.

#### Options

The control deviation between set-point and actual speed (slippage) can be reduced by operating the drive with a speed profile that has been adapted to the mechanics and activated feedforward control.

## Selecting the operating mode

### 5.3.4 Examples

#### 5.3.4.1 Example 1 (reversing operation with a jerk-limited profile)

An elastically coupled load is to be reversed from  $-4096 \text{ min}^{-1}$  to  $+4096 \text{ min}^{-1}$ . To avoid oscillations, braking and acceleration values are limited and a jerk-limited speed profile is selected.

- ✓ The drive is switched on and is operated in PV mode.
- ✓ The speed set-point is  $-4096 \text{ min}^{-1}$ .
  1. Configure the braking and acceleration ramp:
    - In the object 0x6083, set the value **100**.
    - In the object 0x6084, set the value **100**.
  2. Select a jerk-limited profile:
    - In the object 0x6086, set the value **1**.
  3. Select a new set-point:
    - Set the value **4096** in the object 0x60FF.
- ↶ The drive stops and then starts to move again in the opposite direction.

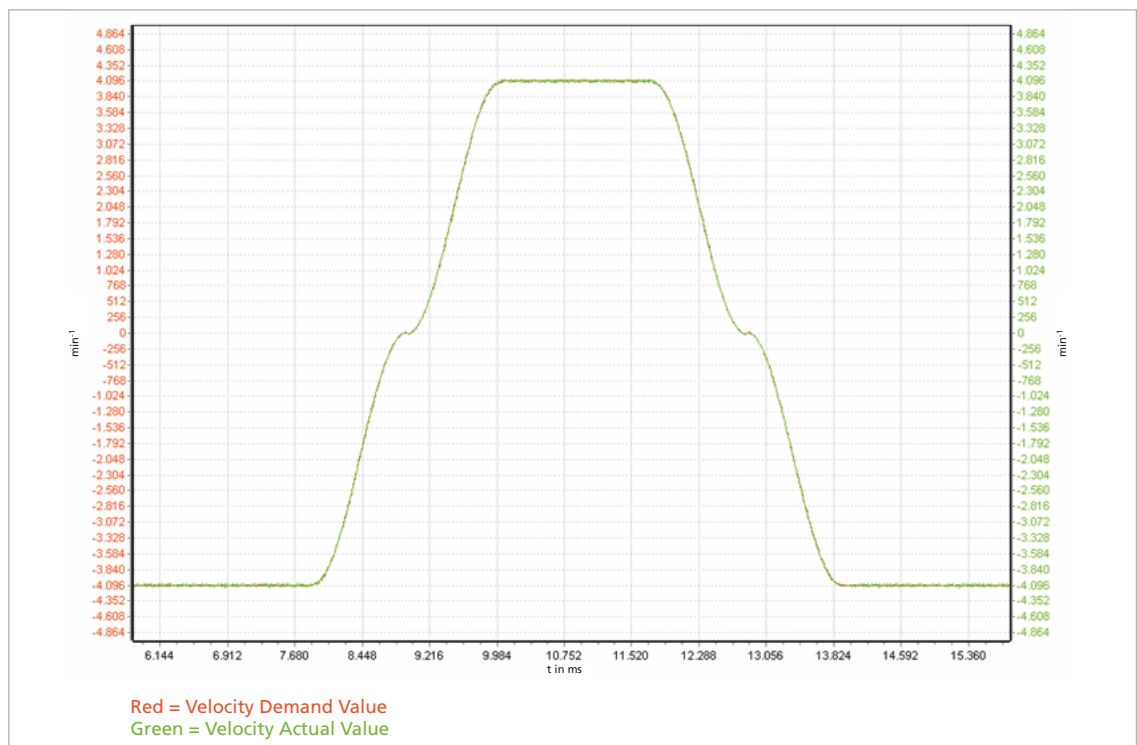

Fig. 36: Speed profile of a reversing operation with a jerk-limited profile

## Selecting the operating mode

### 5.3.4.2 Example 2 (acceleration from an existing movement with a limited acceleration rate)

A load has to be accelerated from  $1000 \text{ min}^{-1}$  to  $5000 \text{ min}^{-1}$ . The load is rigidly coupled.

✓ The drive is switched on and is running in speed-controlled PV mode.

✓ The speed set-point is  $1000 \text{ min}^{-1}$ .

1. Configure the acceleration ramp:
  - In the object 0x6083, set the value **1000**.
2. Select a trapezoidal profile:
  - In the object 0x6086, set the value **0**.
3. Select a new set-point:
  - In the object 0x60FF, set the value **5000**.

↪ The drive will accelerate to  $5000 \text{ min}^{-1}$ .

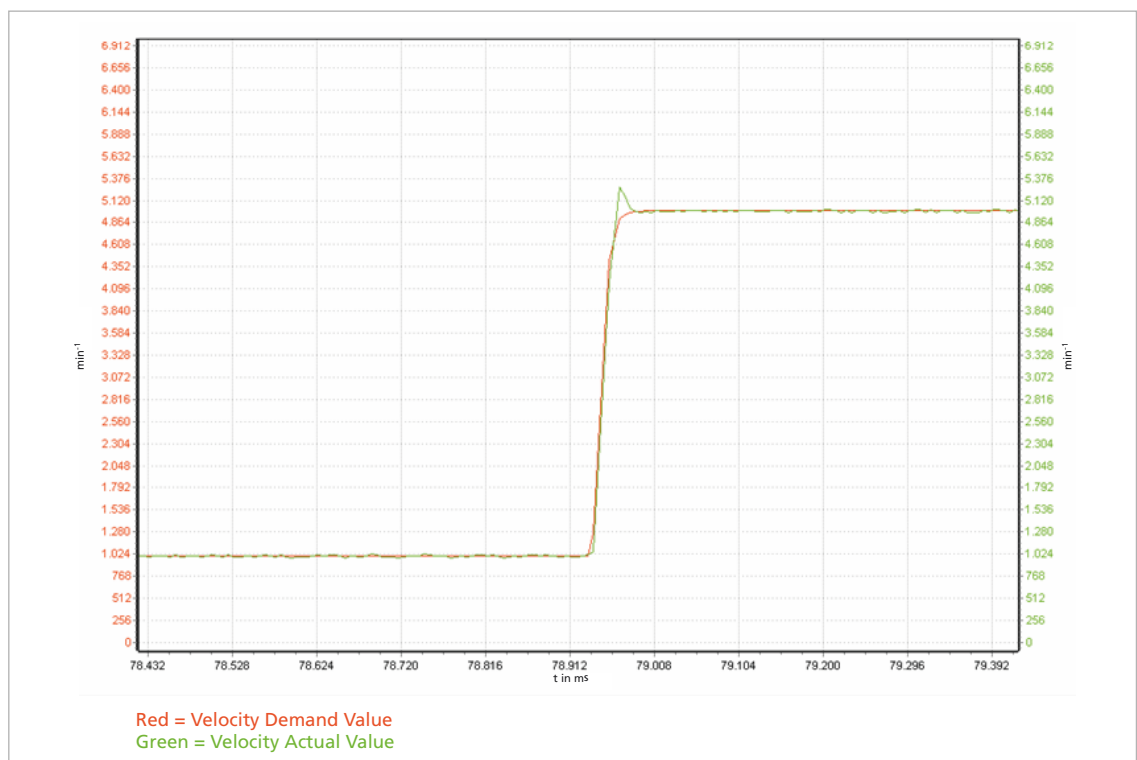

Fig. 37: Speed profile of an acceleration from an existing movement with a limited acceleration rate

## Selecting the operating mode

### 5.4 Homing mode

In most of the cases before position control is to be used, the drive must perform a reference run to align the position used by the drive to the mechanic setup.

The homing methods sketched on the next pages and based on CiA 402 are supported:

- Methods 1...34: A limit switch or an additional reference switch is used as reference.
- Method 37: The position is set to 0 without reference run.
- Methods -1...-4: A mechanical limit stop is set as reference.

**i** Limit switches limit the range of movement (negative/positive limit switch), but at the same time can also be used as reference switches for the zero position.

A homing switch is a dedicated reference switch for the zero position.

**i** The exactness of the reference position can be refined using an index signal. Object 0x2310 is used to configure the inputs to be used as limits switch or as the reference switch (see chap. 4.9.1, p. 76).

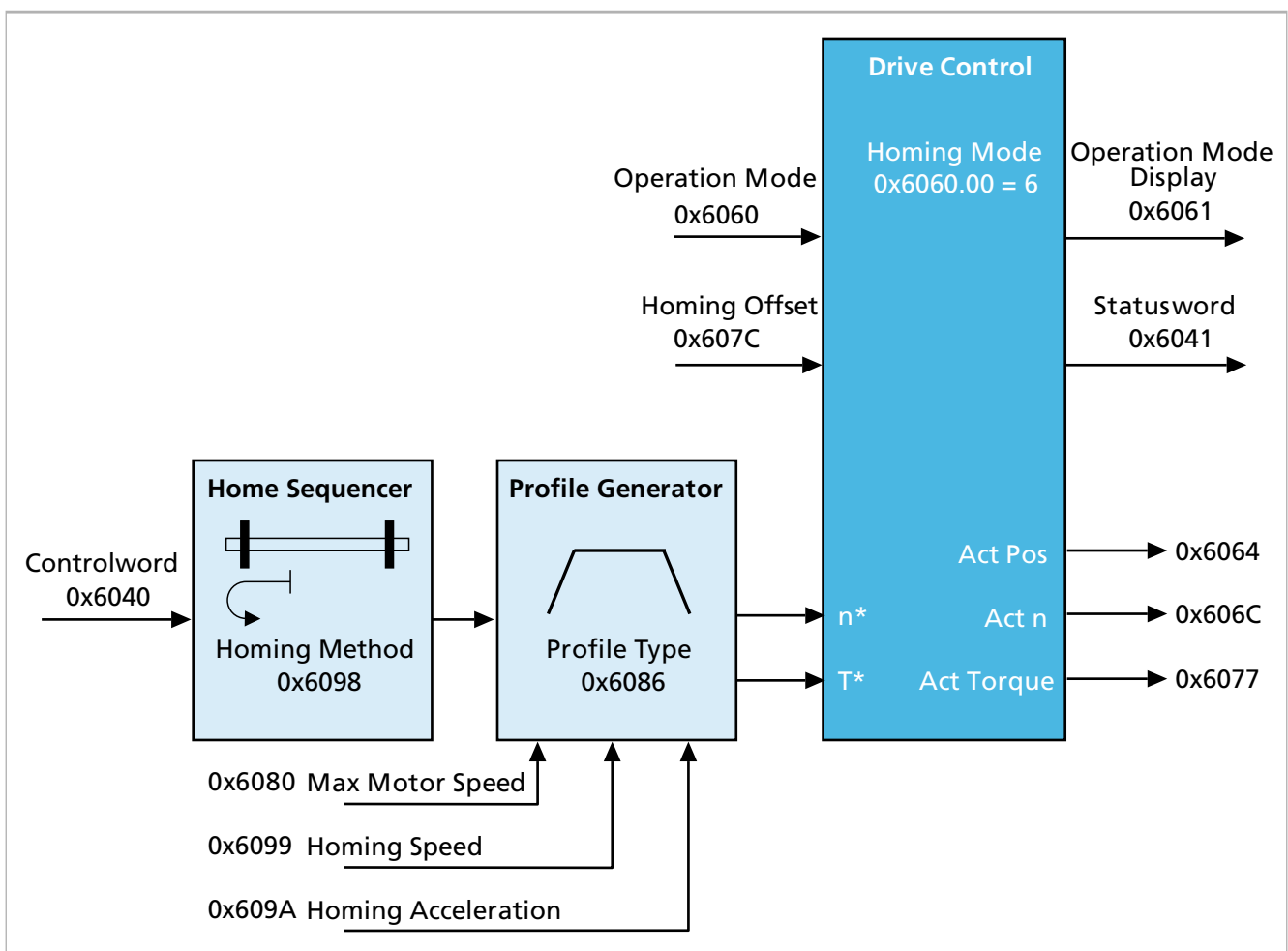

Fig. 38: Overview of Homing mode

**i** During a reference run, the drive is operated in a speed-controlled manner. A separate set of profile parameters is used for the reference run.

## Selecting the operating mode

- i** If the opposing limit switch is reached during a reference run instead of the expected limit switch, the drive still stops, but remains in the limit switch. The reference run must then be interrupted and the configuration must be checked.

### 5.4.1 Homing Methods

#### Methods 1 and 17

Homing to the lower limit switch (negative limit switch):

- If the limit switch is inactive, the drive moves first in the direction of the lower limit switch, until its positive edge is detected. Once the limit switch is active, the drive moves upwards away from the limit switch until the negative edge is detected. Under method 1, additionally the drive moves further to the next index pulse at which the home position is set.

#### Methods 2 and 18

Homing to the upper limit switch (positive limit switch):

- If the limit switch is inactive, the drive moves first in the direction of the upper limit switch, until its positive edge is detected. Once the limit switch is active, the drive moves downwards away from the limit switch until the negative edge is detected. Under method 2, additionally the drive moves further to the next index pulse at which the home position is set.

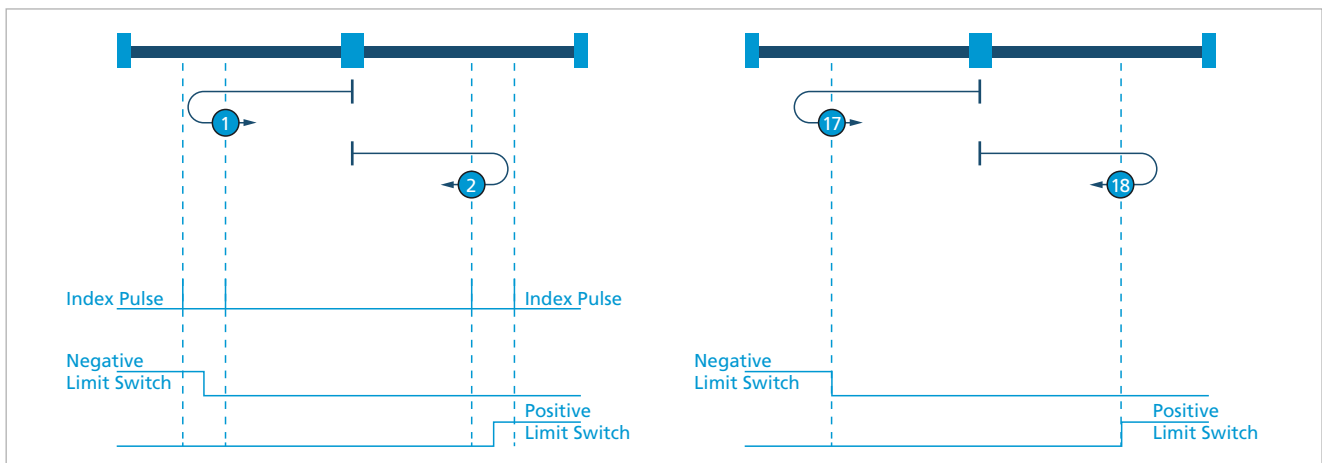

Fig. 39: Homing methods 1, 2, 17 and 18

Under methods 17 and 18, the home position is set at an edge of the selected limit switch. Index pulses are not detected.

## Selecting the operating mode

### Methods 3, 4 and 19, 20

Homing to a positive homing switch

Depending on the state of the homing switch, the drive moves in one direction until the falling (3, 19) or rising (4, 20) edge occurs. A single rising edge of the homing switch is expected in direction towards the upper limit.

The homing position is at the point where the state of the home switch changes.

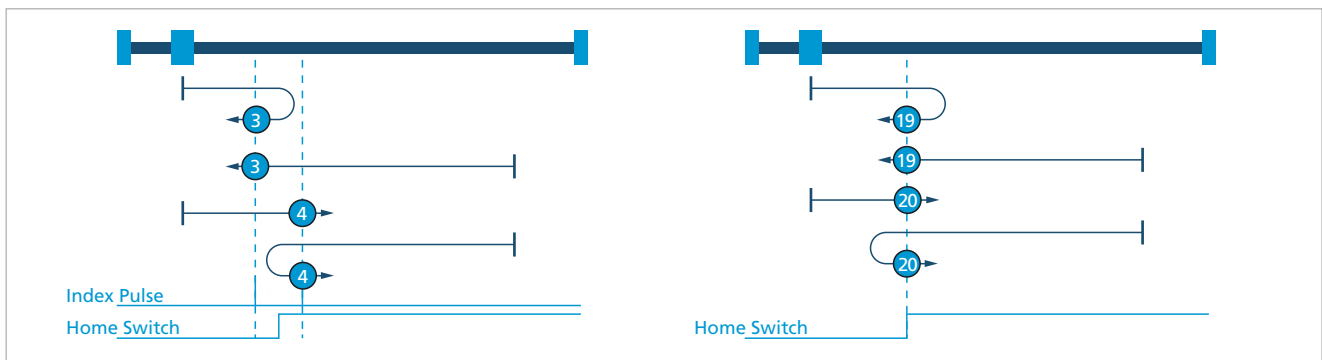

Fig. 40: Homing methods 3, 4, 19 and 20

### Methods 5, 6 and 21, 22

Homing to a negative homing switch

The initial direction of movement depends on the state of the home switch. The homing position is at the point where the state of the home switch changes. If during a reference run the direction of movement has to be reversed, this is always at the point where the state of the home switch changes.

The homing position is at the point where the state of the home switch changes.

Under methods 21 and 22, the home position is set at the edge of the selected limit switch. Index pulses are not detected.

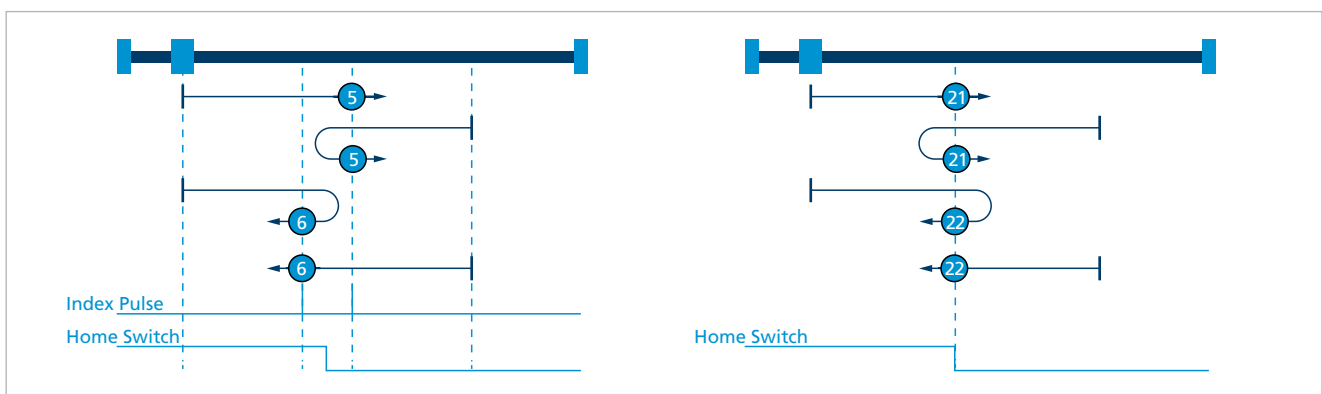

Fig. 41: Homing methods 5, 6, 21 and 22

## Selecting the operating mode

### Methods 7 to 14 and 23 to 30

#### Homing at the homing switch

These methods use a homing switch which is active only in a particular range of movement. In this case the drive must respond differently to the two edges of the home switch.

Under methods 7 to 14, after detection of the edge the drive moves further to the index pulse, at which point the homing position is then set.

Under the methods 23 to 30 the homing position is set at an edge. Index pulses are not detected.

#### ■ Methods 7 and 23:

Homing at the falling edge at the bottom. Starts in a positive direction if the switch is inactive.

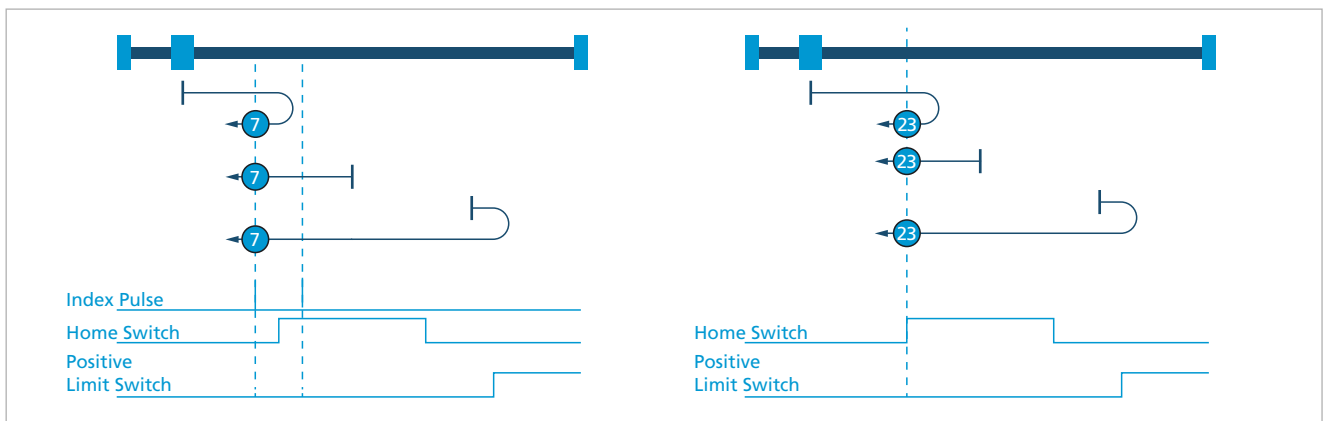

Fig. 42: Homing methods 7 and 23

#### ■ Methods 8 and 24:

Homing at the rising edge at the bottom. Starts in a positive direction if the switch is inactive.

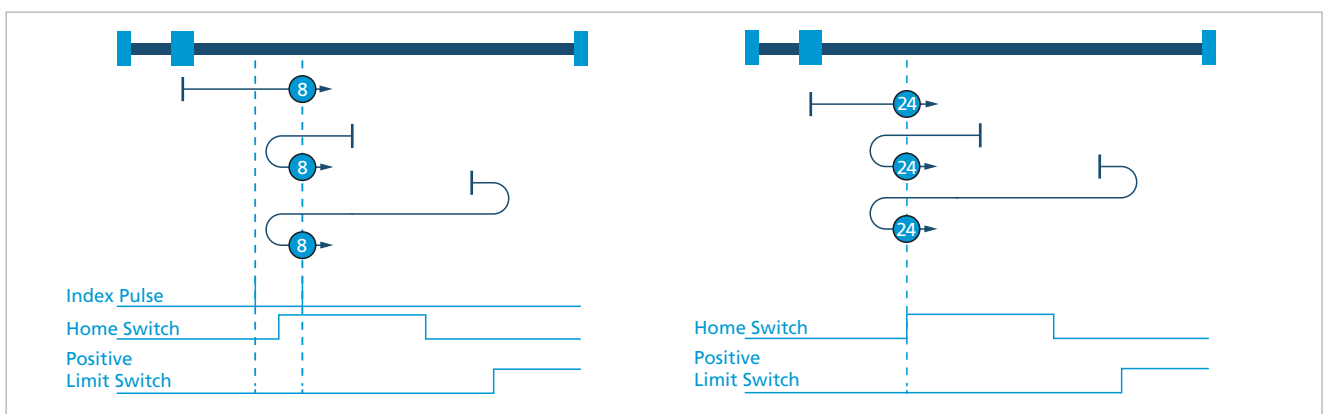

Fig. 43: Homing methods 8 and 24



## Selecting the operating mode

- Methods 9 and 25:

Homing at the rising edge at the top. Always starts in the positive direction.

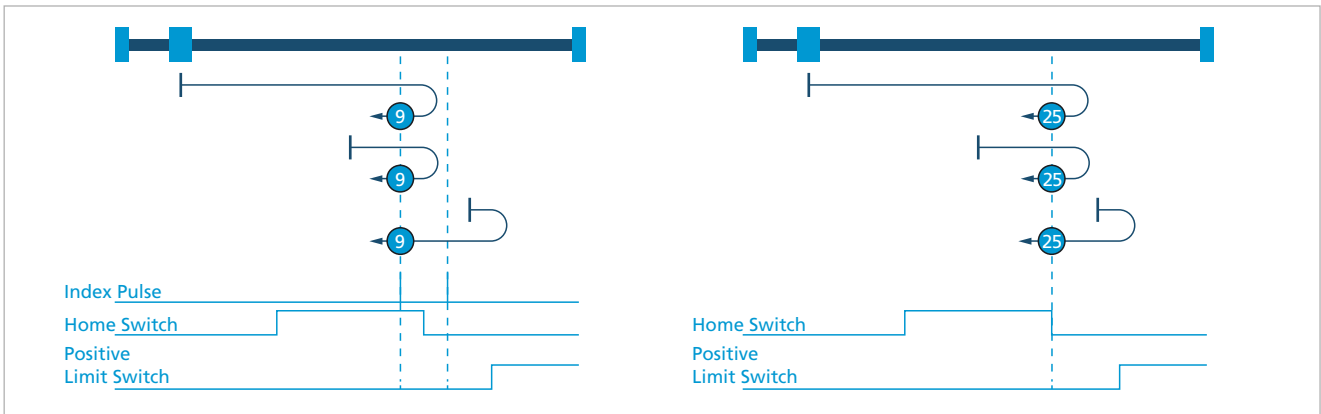

Fig. 44: Homing methods 9 and 25

- Methods 10 and 26:

Homing at the falling edge at the top. Always starts in the positive direction.

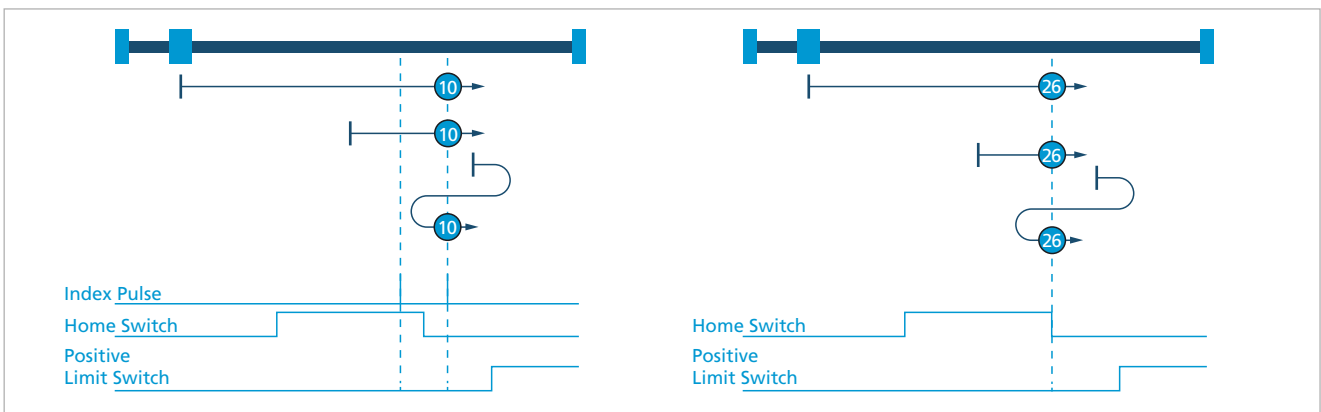

Fig. 45: Homing methods 10 and 26

## Selecting the operating mode

- Methods 11 and 27:

Homing at the falling edge at the top. Starts in a negative direction if the switch is inactive.

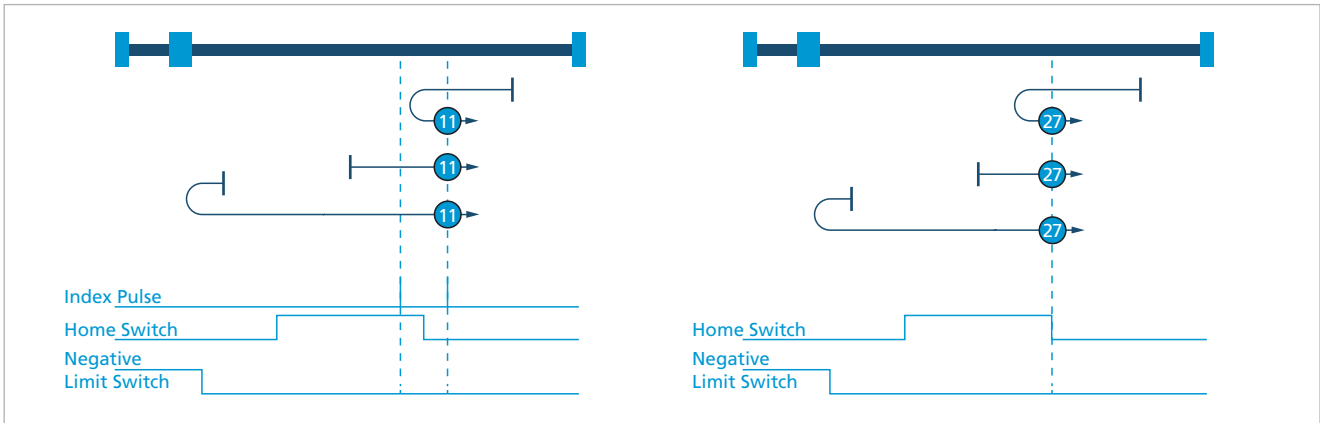

Fig. 46: Homing methods 11 and 27

- Methods 12 and 28:

Homing at the rising edge at the top. Starts in a negative direction if the switch is inactive.

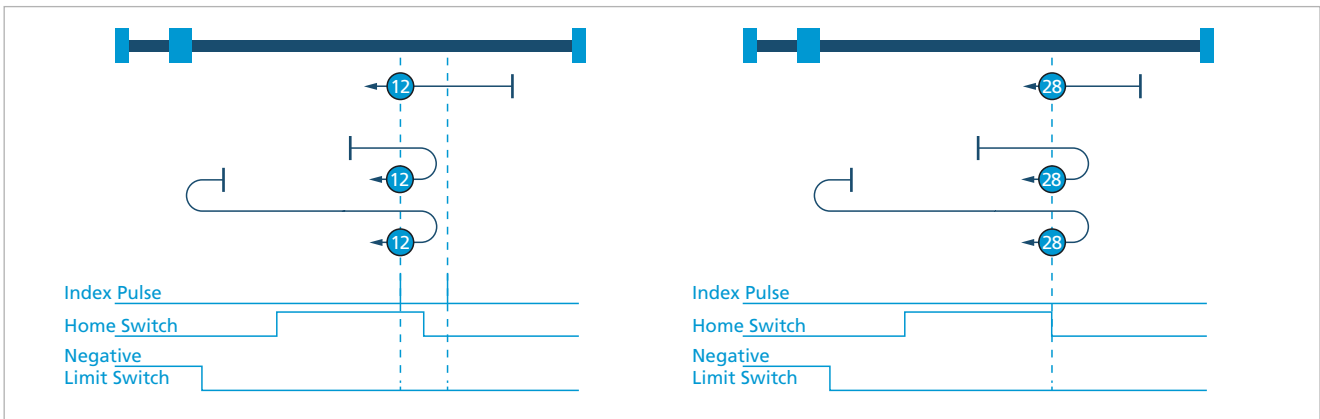

Fig. 47: Homing methods 12 and 28

## Selecting the operating mode

- Methods 13 and 29:

Homing at the rising edge at the bottom. Always starts in the negative direction.

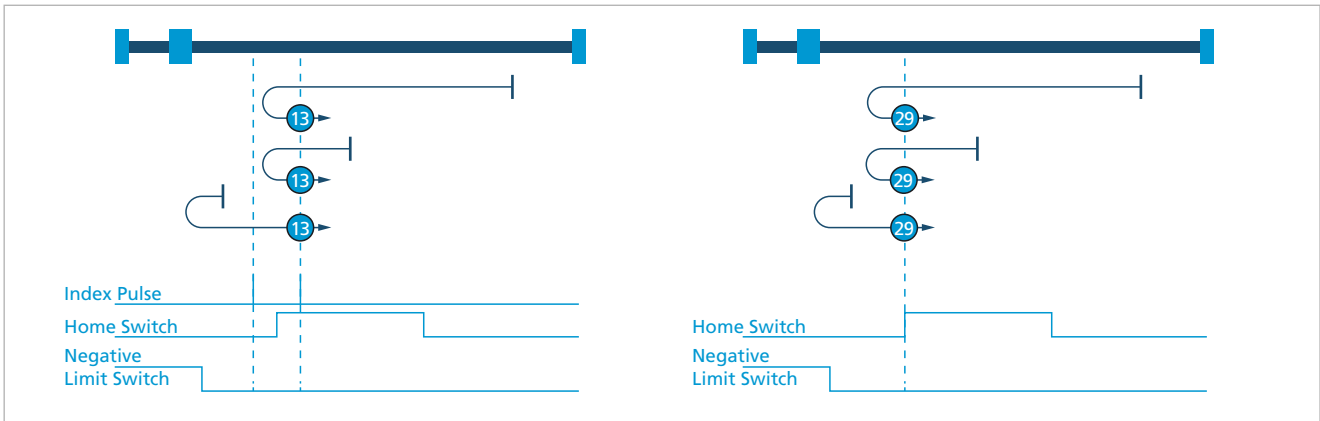

Fig. 48: Homing methods 13 and 29

- Methods 14 and 30:

Homing at the falling edge at the bottom. Always starts in the negative direction.

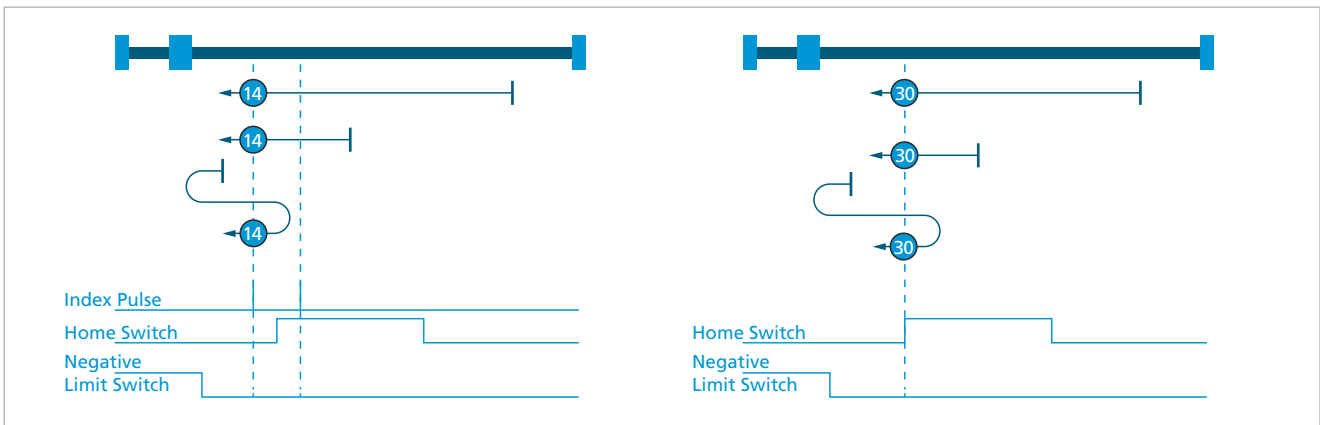

Fig. 49: Homing methods 14 and 30

### Methods 33 and 34

Homing at the index pulse. The drive moves in the negative (33) or positive (34) direction to the index pulse.

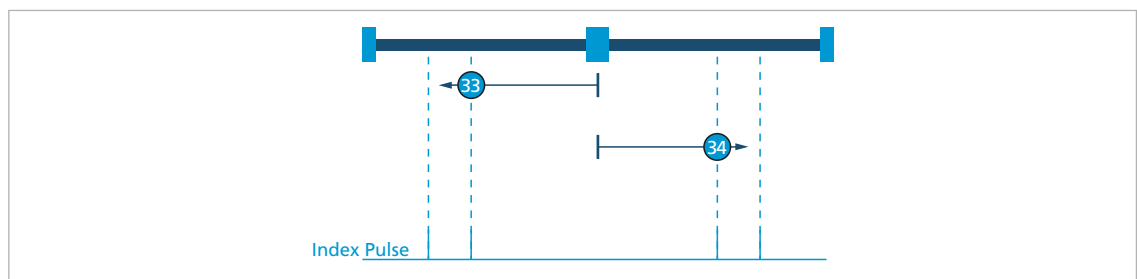

Fig. 50: Homing methods 33 and 34

## Selecting the operating mode

### Method 37

The position counter is zeroed at the current position.

### Methods –1 and –3

Homing at the negative stop:

- The drive moves in the negative direction until a block is detected.
  - In the variant –3, the position there is set to 0.
  - In the variant –1, the drive reverses there and moves to the next index impulse. The position there is set to 0.

**i** After a reference run, make certain that the drive does not remain under mechanical tension and, thus, requires a high motor current. To do this, move the drive a short distance in the positive direction immediately after the reference run.

### Methods –2 and –4

Homing at the positive stop:

- The drive moves in the positive direction until a block is detected.
  - In the variant –4, the position there is set to 0.
  - In the variant –2, the drive reverses there and moves to the next index impulse. The position there is set to 0.

**i** After a reference run, make certain that the drive does not remain under mechanical tension and, thus, requires a high motor current. To do this, move the drive a short distance in the negative direction immediately after the reference run.

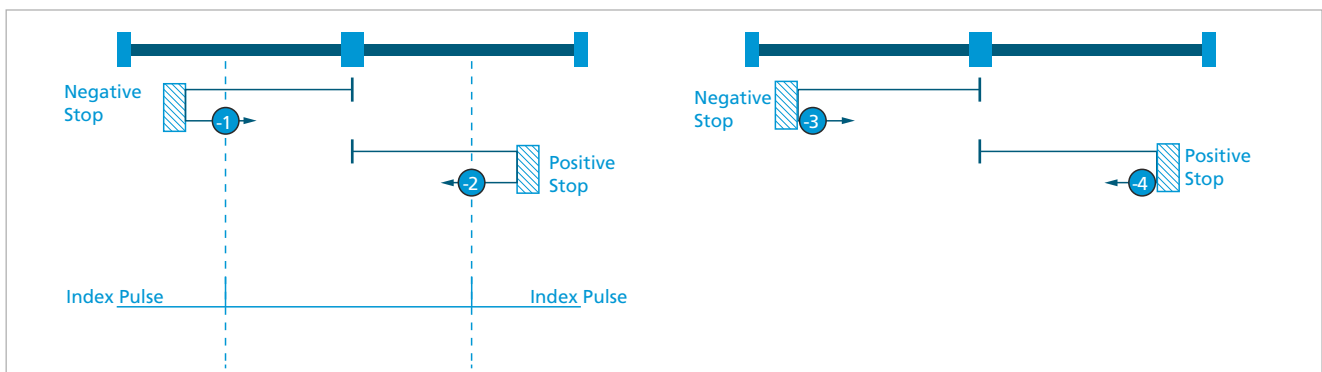

Fig. 51: Homing methods –1, –2, –3 and –4

### Evaluation of the blockage

The drive is evaluated as blocked if the output voltage or the current has reached the set maximum value.

The maximum torque in the event of a blockage can be set using the Torque Limit Value objects (0x60E0 and 0x60E1).

Beginning with firmware revision J, specific torque limits are available in objects 0x2350 and 0x02351 that are activated by default in bit 5 in the Operation Mode Options 0x0233F.

Via object 0x2324.02, a delay time can also be configured. The drive is then only evaluated as blocked after this time has elapsed. It is thereby possible to prevent the drive from inadvertently being referenced at sluggish positions.

## Selecting the operating mode



### NOTICE!

The mechanics can be damaged if the torque limits are set too high.

- ▶ Only perform block runs with adjusted torque limits.

### 5.4.2 Statusword/Controlword Homing mode

In Homing mode, operating mode-specific bits are used in the controlword and statusword.

Tab. 54: Operating mode-specific bits of the controlword (Homing mode)

Bit	Function	Description
4	Homing operation start	0: Do not start Homing 0 → 1: Start Homing

Tab. 55: Operating mode-specific bits of the statusword (Homing mode)

Bit	Function	Description
10	Target Reached	0: Speed ≠ 0 1: Speed = 0
12	Homing attained	0: Homing procedure not completed 1: Homing procedure completed
13	Homing Error	0: No error detected 1: Error detected

Tab. 56: Available bit combinations of the statusword and their meaning

Bit 13	Bit 12	Bit 10	Meaning
0	0	0	Homing procedure active
0	0	1	Homing procedure interrupted or not started
0	1	0	Homing procedure has been completed, the speed is not yet 0
0	1	1	Homing procedure has been successfully completed
1	0	0	A homing error has occurred, speed is not 0
1	0	1	A homing error has occurred, speed is 0
1	1	X	Reserved



If analog Hall signals are used, an index signal is generated internally once per pole pair.

If AES or SSI sensors are used, an index signal is generated internally once per revolution.

## Selecting the operating mode

### 5.4.3 Settings

#### Homing Method

Index	Subindex	Name	Type	Attr.	Default value	Meaning
0x6098	0x00	Homing Method	S8	rw	0	Homing method

#### Homing offset

Index	Subindex	Name	Type	Attr.	Default value	Meaning
0x607C	0x00	Homing Offset	S32	rw	0	Offset of the zero position relative to the position of the reference switch in user-defined units

#### Homing Speed

Index	Subindex	Name	Type	Attr.	Default value	Meaning
0x6099	0x00	Number of Entries	U8	ro	2	Number of object entries
	0x01	Switch Seek Velocity	U32	rw	400	Speed during search for switch
	0x02	Homing Speed	U32	rw	400	Speed during search for zero

#### Homing Acceleration

Index	Subindex	Name	Type	Attr.	Default value	Meaning
0x609A	0x00	Homing Acceleration	U32	rw	50	Acceleration during homing

#### Limit Check Delay Time



Index	Subindex	Name	Type	Attr.	Default value	Meaning
0x2324	0x02	Limit Check Delay Time	U16	rw	10	Delay time until blockage detection [ms]

#### Homing Torque Limits

Index	Subindex	Name	Type	Attr.	Default value	Meaning
0x2350	0x00	Positive Torque Limit Homing	U16	rw	1000	Upper limit value for the reference run in 1/1000 of the rated motor torque
0x2351	0x00	Negative Torque Limit Homing	U16	rw	1000	Lower limit value for the reference run in 1/1000 of the rated motor torque

## Selecting the operating mode

### 5.4.4 Example of a homing reference run

- ✓ Drive state is *Operation Enabled*
- ✓ Modes of Operation (object 0x6060) is set to Homing mode
- ✓ Assign the desired values to the following objects:
  - Homing limit switch (object 0x2310)
  - Homing method (object 0x6098)
  - Homing speed (object 0x6099)
  - Homing acceleration (object 0x609A)
- ▶ In the controlword, set bit 4 (Homing Operation Start) to 1.
- ↺ The drive responds with 0 at bit 12 and bit 10 of the statusword.
- ↺ The drive will now start the reference run.
- ↺ When the homing position is reached and the reference run has been completed, bit 12 and bit 10 of the statusword will be set to 1.
-  Before another reference run can be performed, bit 4 in the controlword must be reset once again. This causes bit 12 in the statusword to be reset.
-  If the reference run is not completed and bit 13 of the statusword indicates an error, the cause typically is a missing configuration of a necessary input in object 0x2310.

## Selecting the operating mode

### 5.5 Cyclic Synchronous Position mode (CSP)

#### 5.5.1 Basic function

In the Cyclic Synchronous Position operating mode, the Motion Controller controls the position of the drive. The set-point is specified via object 0x607A by the master or via a local sequence program. Scaling of the set-points and actual values via the factor group is always taken into account.

Unlike Profile Position mode, the speed profile is calculated in the master and not in the drive (slave). Settings for the speed profile are not taken into account by the Motion Controller.

Cyclic Synchronous Position mode is especially well suited for combination with industrial master controls that generate interpolated movements for multiple axes. Here, the master specifies the target position in short, cyclical intervals. The drive then performs the torque control, speed control and position control.

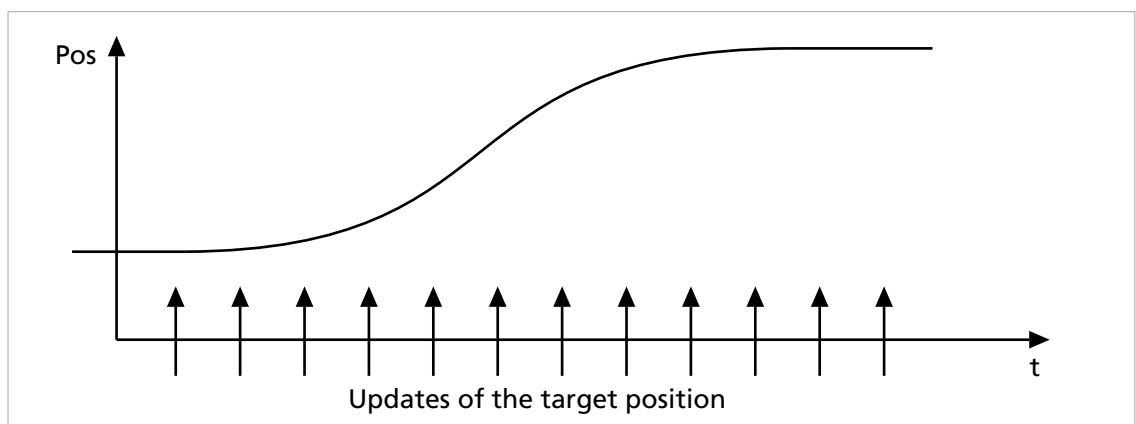

Fig. 52: Cyclical updates of the set-point

Optionally, the master can provide additional values to the speed and torque feedforward control.



## Selecting the operating mode

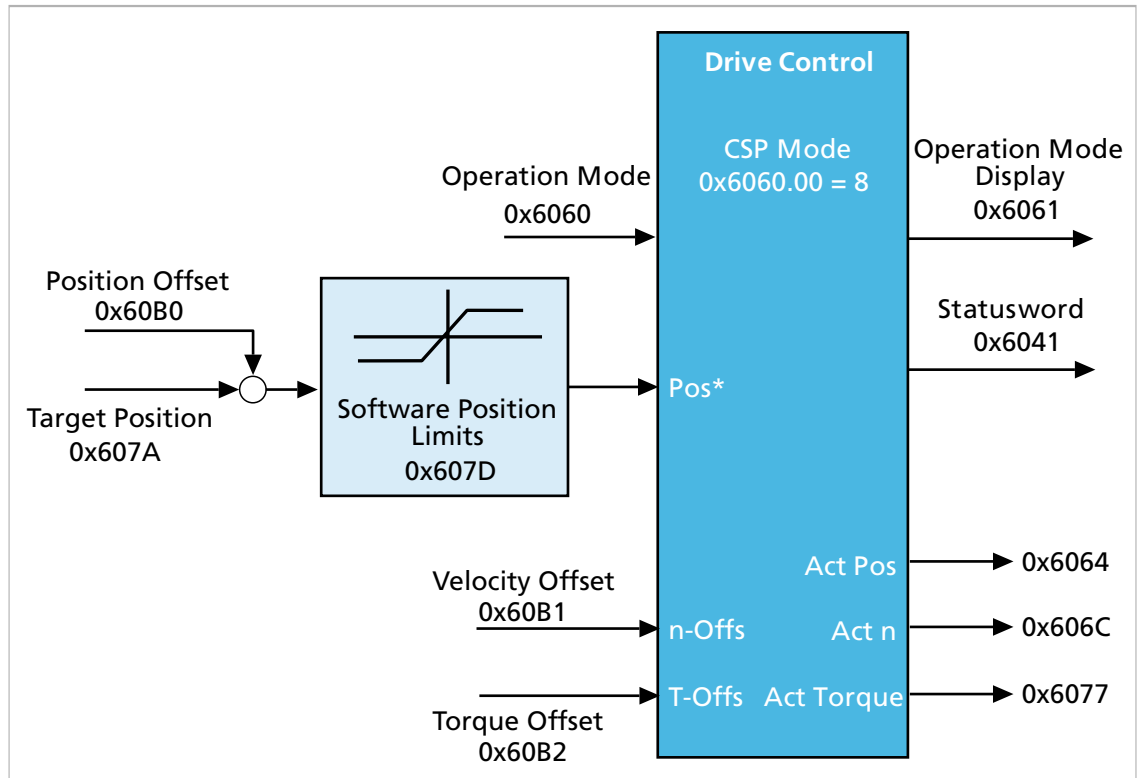

Fig. 53: Overview of Cyclic Synchronous Position mode

The position set-point can be specified in two different ways:

- **Absolute set-point:**

In Cyclic Synchronous Position mode, set-points are interpreted as absolute value. The next position to be reached is specified as the target. The set-point should be generated incrementally.

- **Cyclical set-point:**

For rotary tables, the position range can be limited to one revolution of the application via the position ranges. With the Position Option Code in object 0x60F2, you can then set that the next position is to be reached via the shortest distance.

### Starting a movement task

- Each newly received target position is immediately passed to the controller as set-point. No explicit start of the movement takes place.
- If the master has also calculated pre-control values for the speed and the torque in addition to the position set-point, these can be applied in addition via offsets 0x60B1 and 0x60B2. The following error can thereby be reduced.
- The controller provides the possibility of interpolating between two consecutive set-point values of a cyclic interval. This smooths the movement significantly. To activate this option, check the refresh rate of the master and set object 0x2332 accordingly in multiples of 100  $\mu$ s.

## Selecting the operating mode

### Effective sub-functions

- Control of the position via the controller according to chap. 4.3, p. 25
- Measurement of the actual values
- Monitoring of the movement for slippage and following error
- Optional: Torque and motor speed limitation
- Estimate of the motor temperature and output stage temperature as a protective function
- Monitoring of the movement range via the Software Position Limits and limit switches

### 5.5.2 Statusword/controlword Cyclic Synchronous Position mode

In Cyclic Synchronous Position operating mode the controlword is not assigned to any operating mode-specific bits. Operating mode-specific bits are assigned to the statusword.

*Tab. 57: Operating mode-specific bits of the statusword (Cyclic Synchronous Position mode)*

Bit	Function	Description
10	Reserved	0: Reserved
12	The drive follows the command value	0: The drive does not follow the command value; the target position is ignored 1: The drive follows the operating value, the target position is used as an input to the position control
13	FollowingError	0: The actual position follows the instructions without a following error 1: Permissible range for the following error exceeded

## Selecting the operating mode

### 5.5.3 Control structure in Cyclic Synchronous Position mode

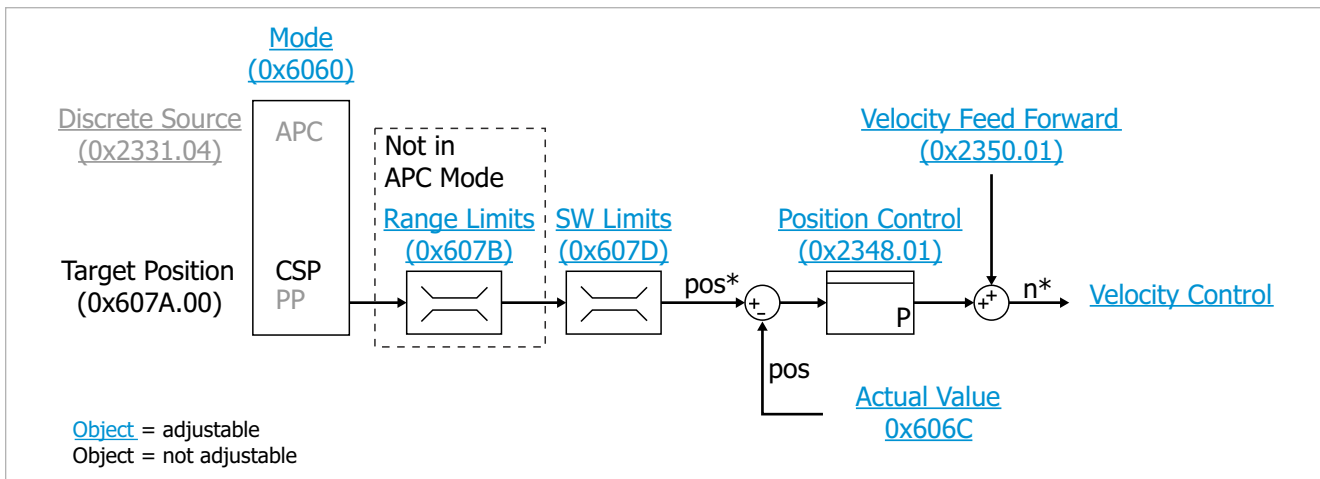

Fig. 54: Motion Manager view of the Cyclic Synchronous Position mode

### 5.5.4 Example

For a servo drive, the target position is specified by the master.

- ✓ Controller parameters are set acc. to chap. 4.3, p. 25
- ✓ Parameters for the following error (Following Error Window) are adapted to the application
- ✓ Operating mode is selected via  $0x6060.00 = 8$
- ✓ Control is activated (the drive is in the *Operation Enabled* state)
- ▶ Write set-point in  $0x607A.00$ .
- ↪ The drive begins the movement task immediately. If the set following error is exceeded, this is indicated in bit 13 in the statusword.

## Selecting the operating mode

### 5.5.5 Options for operation with cyclical position

#### Linear movement between two end positions

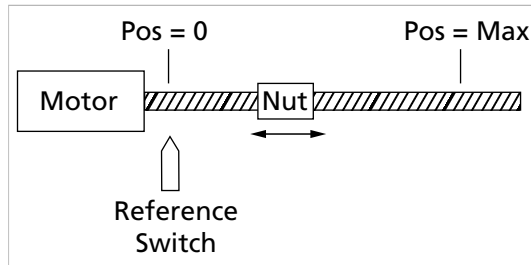

The positions (set-point and actual value) always range between a lower and an upper maximum value. The maximum values can be permanently set via the Software Position Limits (0x607D).

By specifying the next set-point, the movement direction is clearly specified

#### Cyclical rotating movement on a rotary table

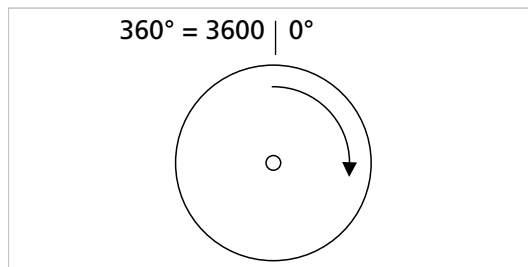

Via the position range limits, the range of the actual position can be limited such that it always corresponds to the absolute position within a revolution, e.g., 0°...360°. The current position within the set range is thereby always indicated, e.g., even after multiple revolutions.

With standard settings, the direction of movement is ascertained from the sign of the following error here as well. Movement is then, e.g., from 350° to 10°, a distance of -340°.

**i** If the motor is coupled to the rotary table via a gearhead, the conversion of rotary table position to motor position can be performed automatically via the gear ratio of the factor group. The set-points and actual values as well as the range limits are then specified in the positions at the output of the gearhead.

#### Options

In the Position Option Code (0x60F2), the behavior of the drive during cyclical rotary movements can be configured.

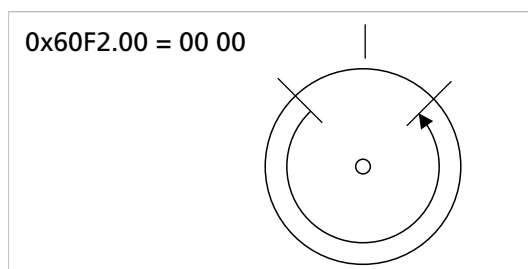

Standard option:

The direction of movement is determined independent of the position range limits from the sign of the control deviation.

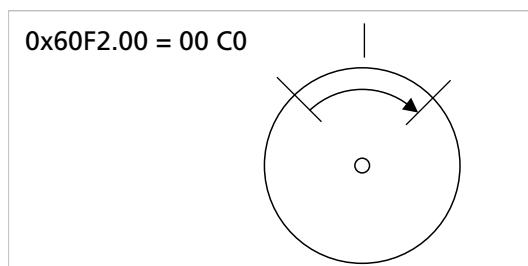

Shortest option:

After specifying a new set-point, the shortest path to the target is travelled, taking into account the position range limits. It is thereby possible to travel beyond the ranges.

## Selecting the operating mode

---

### Example

- ✓ Controller parameters are set acc. to chap. 4.3, p. 25
- ✓ Parameters for following error monitoring (Following Error Window) are adapted to the application
- ✓ Operating mode is selected via  $0x6060.00 = 8$
- ✓ Control is activated (the drive is in the *Operation Enabled* state)
  1. Set Position Option Code in object  $0x60F2.00 = 00C0$ .
  2. Adjusting the movement range:
    - $0x607B.01 = 0$
    - $0x607B.02 = 3599$
  3. Write set-point in the range  $0...3599$  in object  $0x607A.00$ .
- ↪ The drive begins the movement task immediately. If the set following error is exceeded, this is displayed in bit 13 of the statusword.

## Selecting the operating mode

### 5.6 Cyclic Synchronous Velocity mode (CSV)

#### 5.6.1 Basic function

In the Cyclic Synchronous Velocity mode, the Motion Controller controls the speed of the drive. The set-point is specified via object 0x60FF by the master or via a local sequence program. Scaling of the set-points and actual values via the factor group is always taken into account.

Unlike Profile Velocity mode, the speed profile is calculated in the master and not in the drive (slave). Settings for the speed profile are not taken into account by the Motion Controller.

Cyclic Synchronous Velocity mode is especially well suited for combination with industrial master controls that generate interpolated movements for multiple axes. Here, the master specifies the target speed in short, cyclical intervals. The drive then performs the torque and speed control.

Optionally, the master can provide additional values to the torque feedforward control.

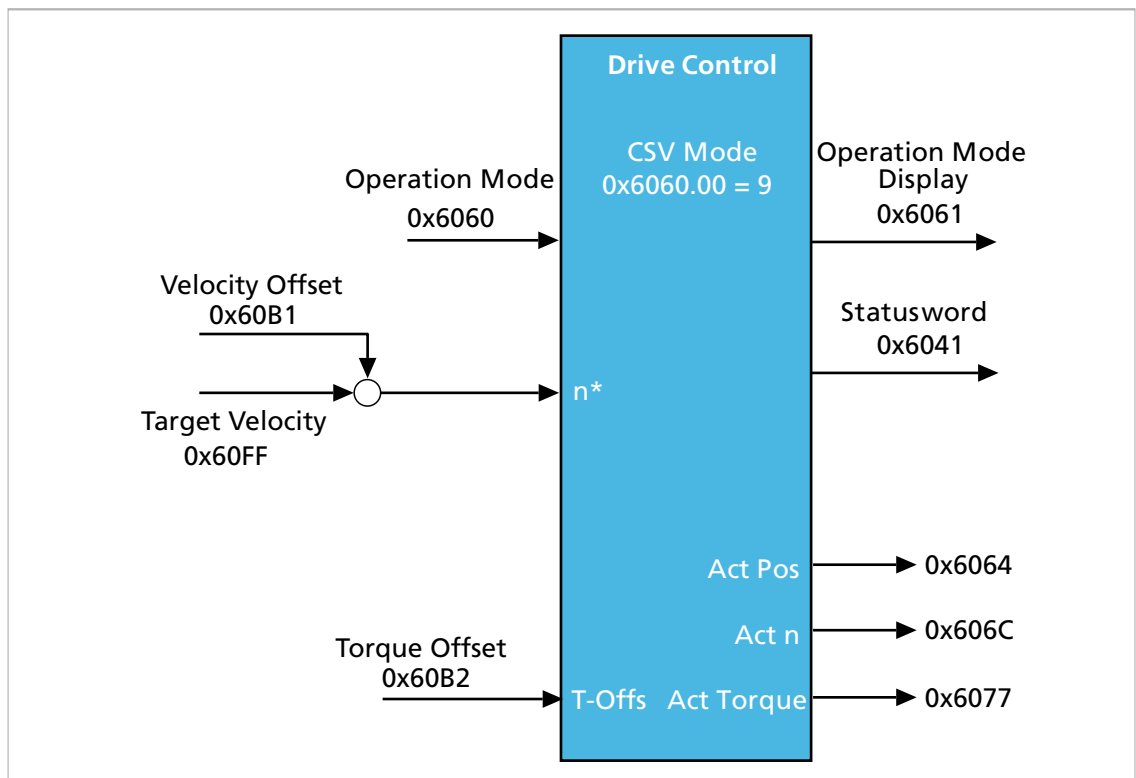

Fig. 55: Overview of Cyclic Synchronous Velocity mode

#### Set-point specification and operation

If the output stage is activated, new set-points are applied immediately. Profile parameters are not taken into account.

The controller provides the possibility of interpolating between two consecutive setpoint values of a cyclic interval. This smooths the movement significantly. To activate this option, check the refresh rate of the master and set object 0x2332 accordingly in multiples of 100  $\mu$ s.

## Selecting the operating mode

### Effective sub-functions

- Control of the speed via the controller according to chap. 4.3, p. 25
- Measurement of the actual values
- Optional: Torque and motor speed limitation
- Estimate of the motor temperature and output stage temperature as a protective function
- Optional: Monitoring of the movement range via the Software Position Limits and limit switches

### 5.6.2 Statusword/Controlword Cyclic Synchronous Velocity mode

In Cyclic Synchronous Velocity mode the controlword is not assigned to any operating mode-specific bits. Operating mode-specific bits are assigned to the statusword.

Tab. 58: Operating mode-specific bits of the statusword (Cyclic Synchronous Velocity mode)

Bit	Function	Description
10	Reserved	0: Reserved
12	The drive follows the command value	0: Drive does not follow the command value; Target Velocity is ignored 1: The drive follows the operating value, Target Velocity is used as input of speed control
13	Reserved	0: Reserved

### 5.6.3 Control structure in Cyclic Synchronous Velocity mode

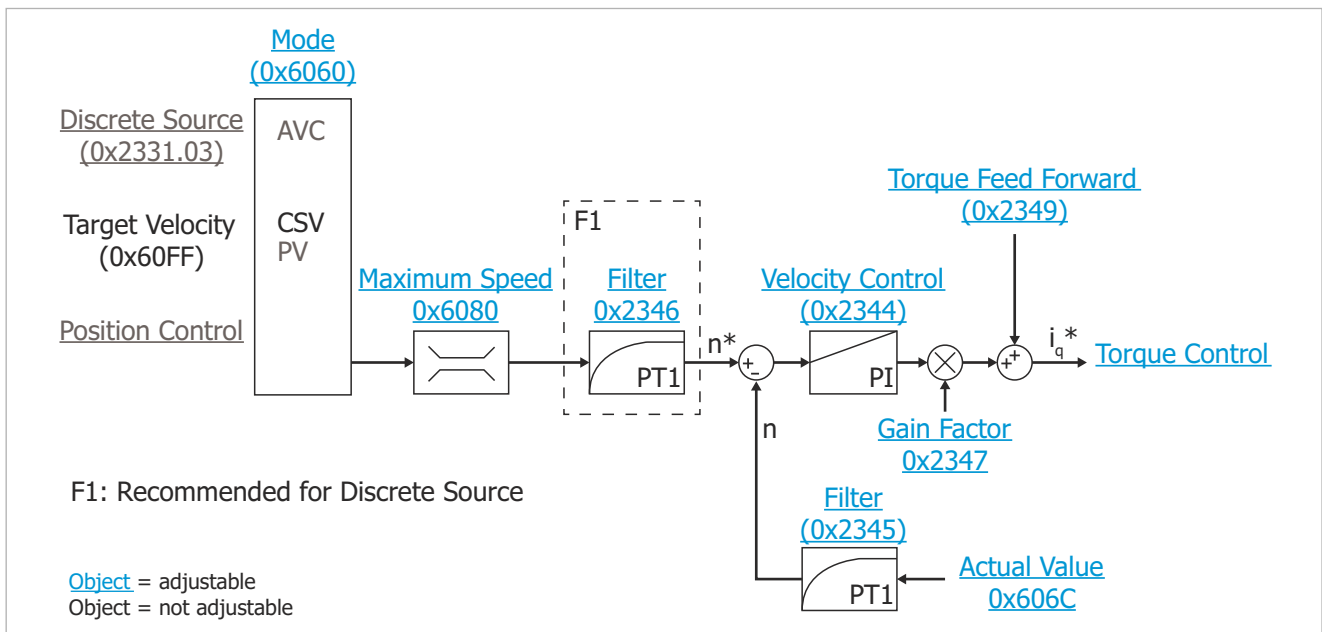

Fig. 56: Motion Manager view of the Cyclic Synchronous Velocity mode

## Selecting the operating mode

---

### 5.6.4 Example

- ✓ Motion Controller and drive are connected
- ✓ Settings have been performed according to chap. 4, p. 24
- ✓ Operating mode has been set (object 0x6060 = 9)
  - ▶ Set the state machine of the drive to the *Operation Enabled* state.
  - ▶ Enter the desired velocity in the Target Velocity (0x60FF) object.
  - ↪ The drive will move at the set speed.



## Selecting the operating mode

### 5.7 Cyclic Synchronous Torque mode (CST)

#### 5.7.1 Basic function

In the Cyclic Synchronous Torque operating mode, the Motion Controller controls the torque or the force of the drive. The set-point is specified via object 0x6071 by the master or via a local sequence program. Settings for the speed profile are not taken into account by the Motion Controller.

Cyclic Synchronous Torque mode is especially well suited for combination with industrial master controls that generate interpolated movements for multiple axes. Here, the master specifies the target torque in short, cyclical intervals. The drive then performs torque control.

No limiting of the speed takes place in the Motion Controller in CST mode. The Velocity Warning Threshold parameter (0x2344.05) allows a maximum speed to be specified above which an error entry is generated in the error monitoring (see chap. 7, p. 156).

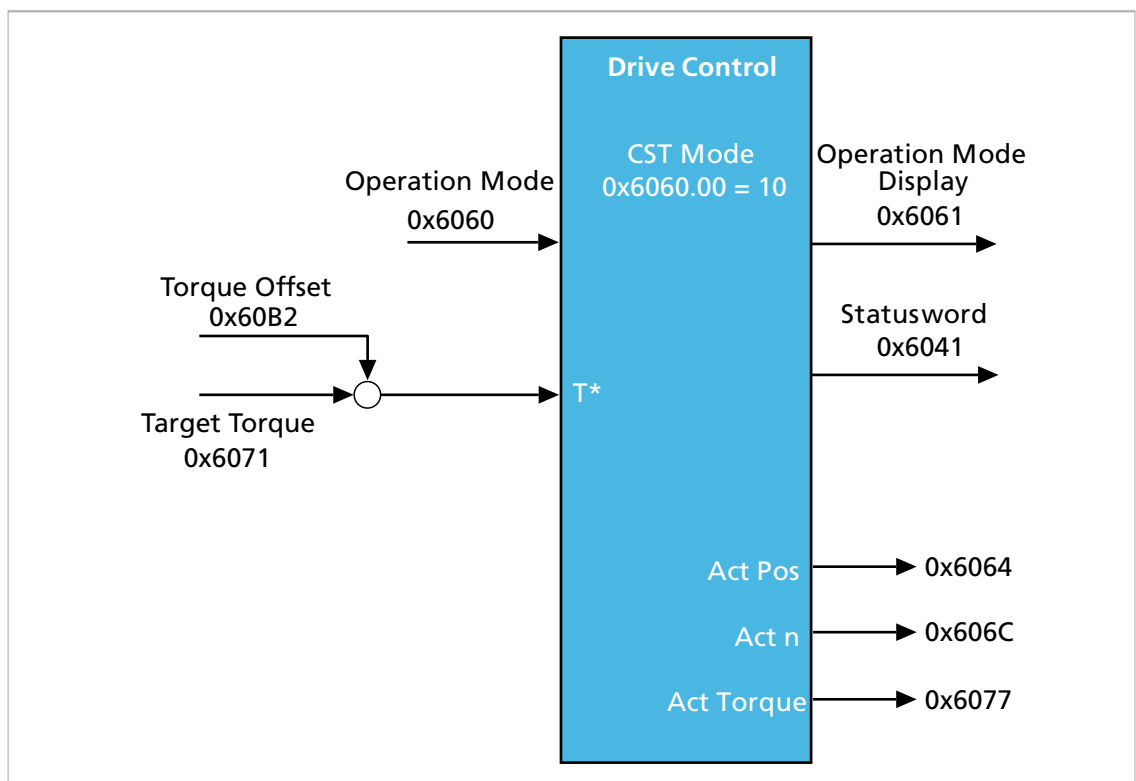

Fig. 57: Overview of Cyclic Synchronous Torque mode

#### Set-point specification and operation

If the output stage is activated, new set-points are applied immediately. Profile parameters are not taken into account.

#### Effective sub-functions

- Control of the torque or force via the controller according to chap. 4.3, p. 25
- Measurement of the actual values
- Optional: Torque or force limitation

## Selecting the operating mode

- Estimate of the motor temperature and output stage temperature as a protective function
- Optional: Monitoring of the movement range via the Software Position Limits and limit switches
- Optional: Monitoring of the speed with respect to a configurable maximum value

### 5.7.2 Statusword/Controlword CST

In Cyclic Synchronous Torque operating mode the controlword is not assigned to any operating mode-specific bits. Operating mode-specific bits are assigned to the statusword.

Tab. 59: Operating mode-specific bits of the statusword (Cyclic Synchronous Torque mode)

Bit	Function	Description
10	Reserved	0: Reserved
12	The drive follows the command value	0: Drive does not follow the command value; Target Torque (object 0x6071) is ignored 1: The drive follows the operating value, Target Torque (object 0x6071) is used as input of torque control
13	Reserved	0: Reserved

### 5.7.3 Control structure in Cyclic Synchronous Torque mode

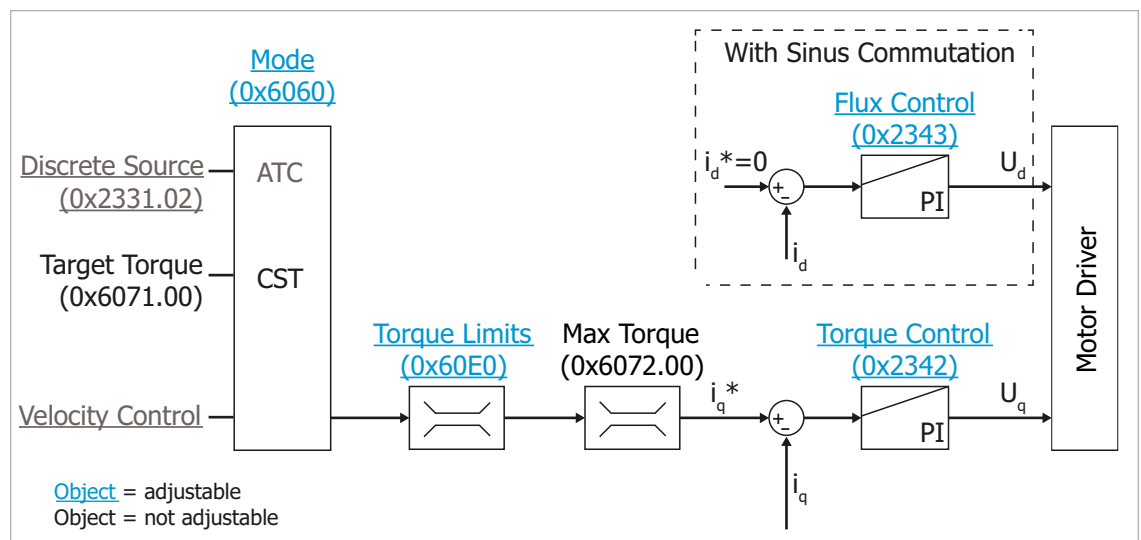



Fig. 58: Motion Manager view of the Cyclic Synchronous Torque mode

## Selecting the operating mode

---

### 5.7.4 Example

- ✓ Motion Controller and drive are connected
- ✓ Settings have been performed according to chap. 4, p. 24
- ✓ Operating mode has been set (object 0x6060 = 10)
  - ▶ Set the state machine of the drive to the *Operation Enabled* state.
  - ▶ Enter the desired torque in the Target Torque (0x6071) object.
  - ↩ The drive will move with the set torque.
-  If the load torque is lower than the required torque, the drive will accelerate to the maximum speed.

## Selecting the operating mode

### 5.8 Voltage Mode

#### 5.8.1 Basic function

In the Voltage mode a motor voltage is output proportional to the specified value. Current limitation still remains active. A supervisory controller can be used in Voltage mode. The controller then acts as a power amplifier.

The voltage specification can be performed via the object 0x2341 or via a discrete input such as an analog value.

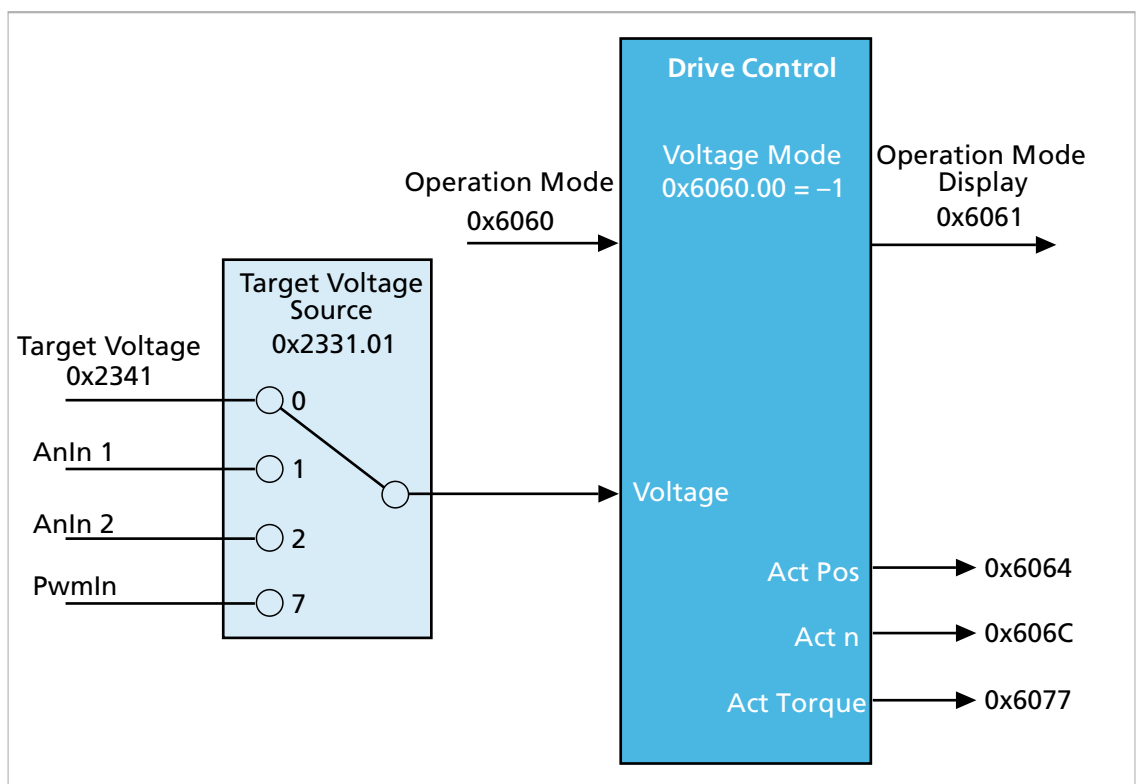

Fig. 59: Overview of Voltage mode

#### Set-point specification and operation

If the output stage is activated, new set-points are applied immediately. The set-point is specified in increments of 10 mV.



#### NOTICE!

**Damage to the mechanics if the analog inputs are set incorrectly**

The AnIn 1 and AnIn 2 analog inputs are set ex works to a value range of  $\pm 10,000 = \pm 10$  V.

- ▶ Before using as voltage set-point, scale the inputs appropriately (see chap. 4.9, p. 75 and chap. 4.7, p. 57).

## Selecting the operating mode

### Effective sub-functions

- Current limitation control via the current controller according to chap. 4.3, p. 25
- Measurement of the actual values
- Estimate of the motor temperature and output stage temperature as a protective function
- Optional: Monitoring of the movement range via the Software Position Limits and limit switches

### 5.8.2 Statusword/Controlword Voltage mode

In Voltage mode there are no operating mode-specific bits in the controlword or statusword.

### 5.8.3 Settings

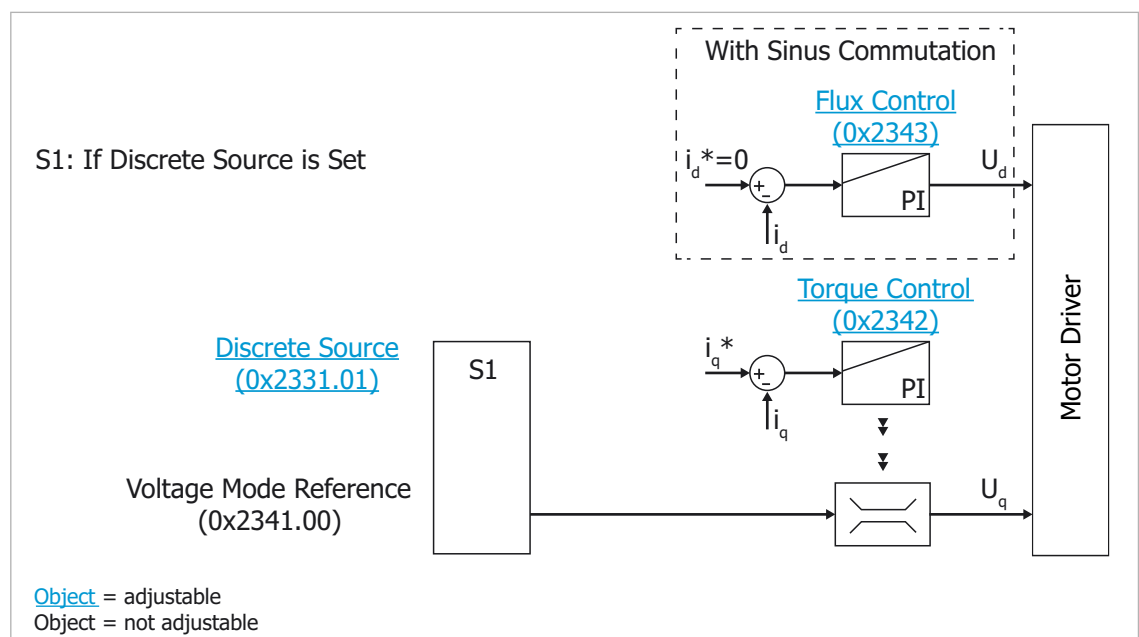

Fig. 60: Motion Manager view of the Voltage mode

The following objects must be set when using this operating mode:

- Operation Mode (0x6060 = -1)
- Discrete Source for Voltage (0x2331.01)
- Optional: Voltage Mode Reference (object 0x2341)

### Voltage Mode Reference

Index	Subindex	Name	Type	Attr.	Default value	Meaning
0x2341	0x00	Voltage Mode Reference	S16	rw	0	Voltage set-point of the Voltage mode [10 mV / digit]

## Selecting the operating mode

### Discrete Source for Ref-Voltage

Index	Subindex	Name	Type	Attr.	Default value	Meaning
0x2331	0x00	Number of Entries	U8	ro	4	Number of object entries
	0x01	Target Voltage Source	U8	rw	0	Selection of the discrete source for the voltage set-point
	0x02	Target Current Source	U8	rw	0	Selection of the discrete source for the torque set value
	0x03	Target Velocity Source	U8	rw	0	Selection of the discrete source for the speed set value
	0x04	Target Position Source	U8	rw	0	Selection of the discrete source for the position set-point

**i** If no discrete source for the set-point is selected via the object 0x2331.01, the value in object 0x2341 is used as the set-point.

The available settings for discrete set-point sources and their meanings can be found in chapter chap. 4.7.2, p. 60.

### 5.8.4 Example

- ✓ Motion Controller and drive are connected
- ✓ Settings have been performed according to chap. 4, p. 24
- ▶ Set the operating mode (0x6060 = -1)
- ▶ Configure the set-point via the communications system in object 0x2341 or via a discrete voltage specification in object 0x2331.01.
  - If specifying the set-point via the communications system, set the set-point source value in object 0x2331.01 to 0
  - If specifying the set-point by discrete voltage specification, set the set-point source as described in chap. 4.7.2, p. 60.
- ▶ Set the state machine of the drive to the *Operation Enabled* state.
- ▶ If specifying the set-points via the communications system, set the set-points via a write access to the object 0x2341
- ↪ The motor will move with the specified voltage. Current, speed and position are uncontrolled and they vary as a result of voltage and load.

## Selecting the operating mode

### 5.9 Analog Position Control mode (APC)

#### 5.9.1 Basic function

In the Analog Position Control (APC) operating mode the Motion Controller controls the position of the drive. The position set-point is specified via a discrete input. Profile parameters are not taken into account. The set-point is applied directly to the control.

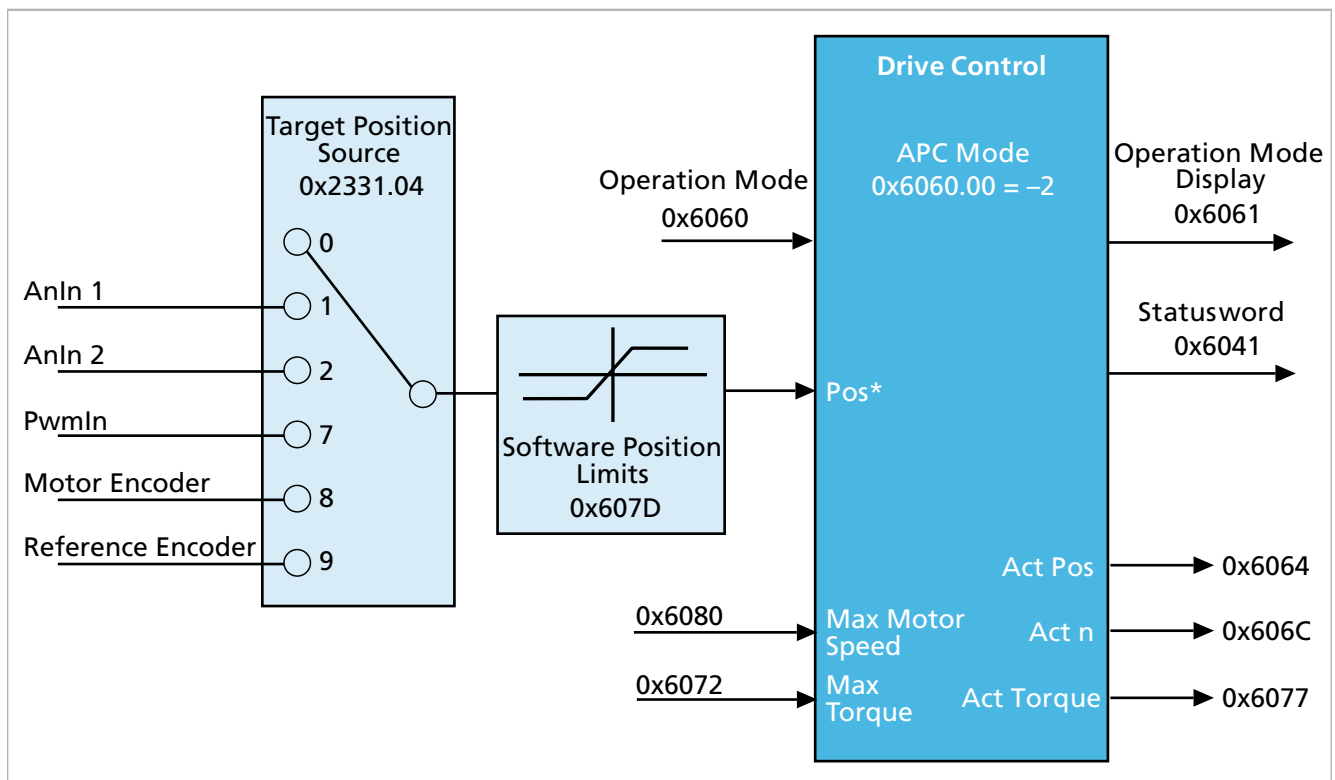

Fig. 61: Overview of Analog Position Control mode

#### Set-point specification and operation

If the output stage is activated, new set-points are applied immediately. The set-point must be specified for the controller in increments of the position encoder.

Tab. 60: Set-point sources

Sources	Set-point specification
<ul style="list-style-type: none"> <li>Analog input (AnIn 1 / AnIn 2)</li> <li>PWM input</li> </ul>	The set-point specifies the absolute position to which the drive is to be moved.
<ul style="list-style-type: none"> <li>Position specification via a quadrature signal (motor encoder or reference encoder)</li> <li>Position specification via a pulse/direction signal</li> </ul>	As set-point, the quadrature pulses are counted after changing to the operating mode. The set-point is therefore interpreted as the distance by which the drive is to move (relative set-point).



#### NOTICE!

**Damage to the mechanics if set-points are scaled incorrectly**

- ▶ Scale all set-point sources appropriately before using.

## Selecting the operating mode

Tab. 61: Scaling of the set-point sources (see chap. 4.6, p. 49)

Input	Parameter
Analog inputs	Gain and offset in object 0x2313
PWM input	Gain and offset in object 0x2317
Quadrature signal via the motor encoder	Gain in object 0x2315
Quadrature signal via the reference encoder	Gain in object 0x2316
Position specification via a pulse/direction signal	Gain in object 0x2316

### Effective sub-functions

- Control of the position via the controller according to chap. 4.3, p. 25
- Measurement of the actual values
- Monitoring of the movement for slippage and following error
- Optional: Torque and speed limitation
- Estimate of the motor temperature and output stage temperature as a protective function
- Monitoring of the movement range via the Software Position Limits and limit switches

### 5.9.2 Controlword/statusword for Analog Position Control mode

In Analog Position Control mode there are no operating mode-specific bits in the controlword or statusword.

### 5.9.3 Settings

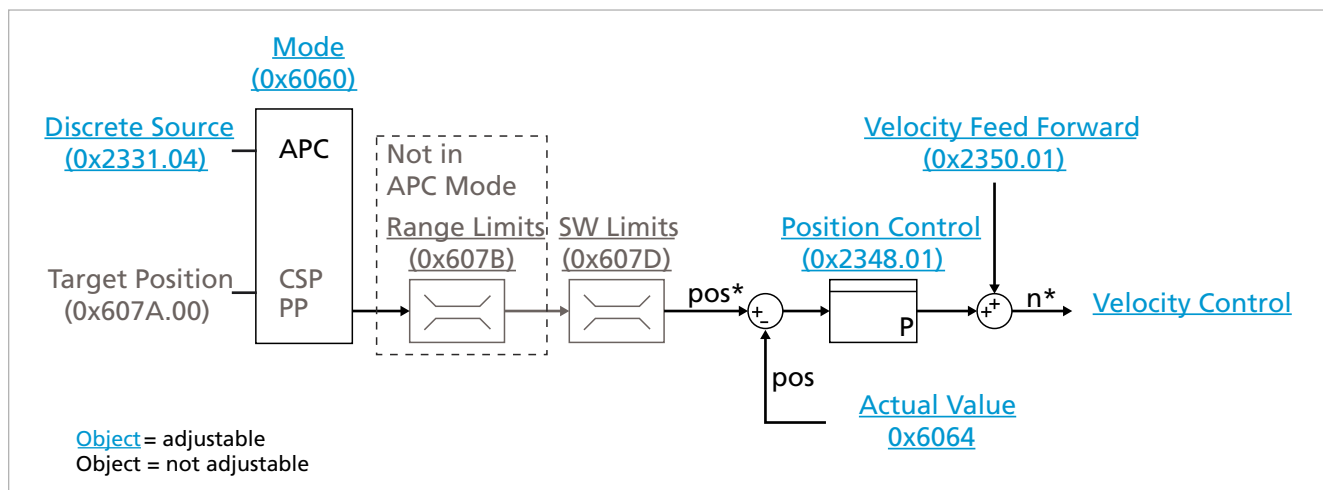

Fig. 62: Motion Manager view of the Analog Position Control mode

The following objects must be set when using this operating mode:

- Operation Mode (0x6060 = -2)
- Discrete Source for Reference Position (0x2331.04)





## Selecting the operating mode

### 5.9.4 Examples

#### 5.9.4.1 Specification of a target position for a servo drive via an analog voltage

- ✓ Motor is selected via the Motion Manager
- ✓ Controller parameters are set acc. to chap. 4.3, p. 25
- ✓ Set-point channel is scaled and selected as set-point source for the position controller according to chap. 4.7, p. 57
- ✓ Control is activated (the drive is in the *Operation Enabled* state)
  - ▶ Optional: Perform reference run, e.g., using a BASIC script immediately after starting
  - ▶ Select operating mode via object 0x6060 = -2.
- ↪ The drive immediately adjusts the actual position to the preset target position.

 Motion Controllers can be configured via bit 2 in the Operation Mode Options object (0x233F.00) so that the output stage is activated immediately after starting.

 If a reference run is first to be automatically performed when switching on the power supply, this can be done autonomously using a BASIC script. An example is provided in the programming manual.

#### 5.9.4.2 Specification of a position on an actuator via a pulse/direction signal

A BL motor with analog Hall signals is used as actuator (4096 increments/revolution). For every 500 pulses of the control signal, the drive is to move one revolution.

- ✓ Motor is selected via the Motion Manager
- ✓ Controller parameters are set acc. to chap. 4.3, p. 25
- ✓ Reference encoder is configured for a pulse-direction signal (see chap. 4.9, p. 75)
- ✓ Reference encoder is configured with 0x2331.04 = 9 as set-point source for the APC
- ✓ Pulse signal is connected to DigIn 1, direction signal is connected to DigIn 2 and the threshold values are appropriately scaled.
- ✓ Control is activated (the drive is in the *Operation Enabled* state)
  - ▶ Scaling the set-point channel with the gain in parameter 0x2316.04:
 
$$\text{target position} - \text{change} = \text{pulse number} * \frac{4096}{500}$$
  - ▶ Optional: Perform reference run.
  - ▶ Select APC operating mode with 0x6060.00 = -2.
- ↪ The drive follows the incoming pulses.

## Selecting the operating mode

### 5.10 Analog Velocity Control mode (AVC)

#### 5.10.1 Basic function

In the Analog Velocity Control operating mode the Motion Controller controls the speed of the drive. The speed set-point is specified via a discrete input.

Profile parameters are not taken into account. The set-point is applied directly to the control.

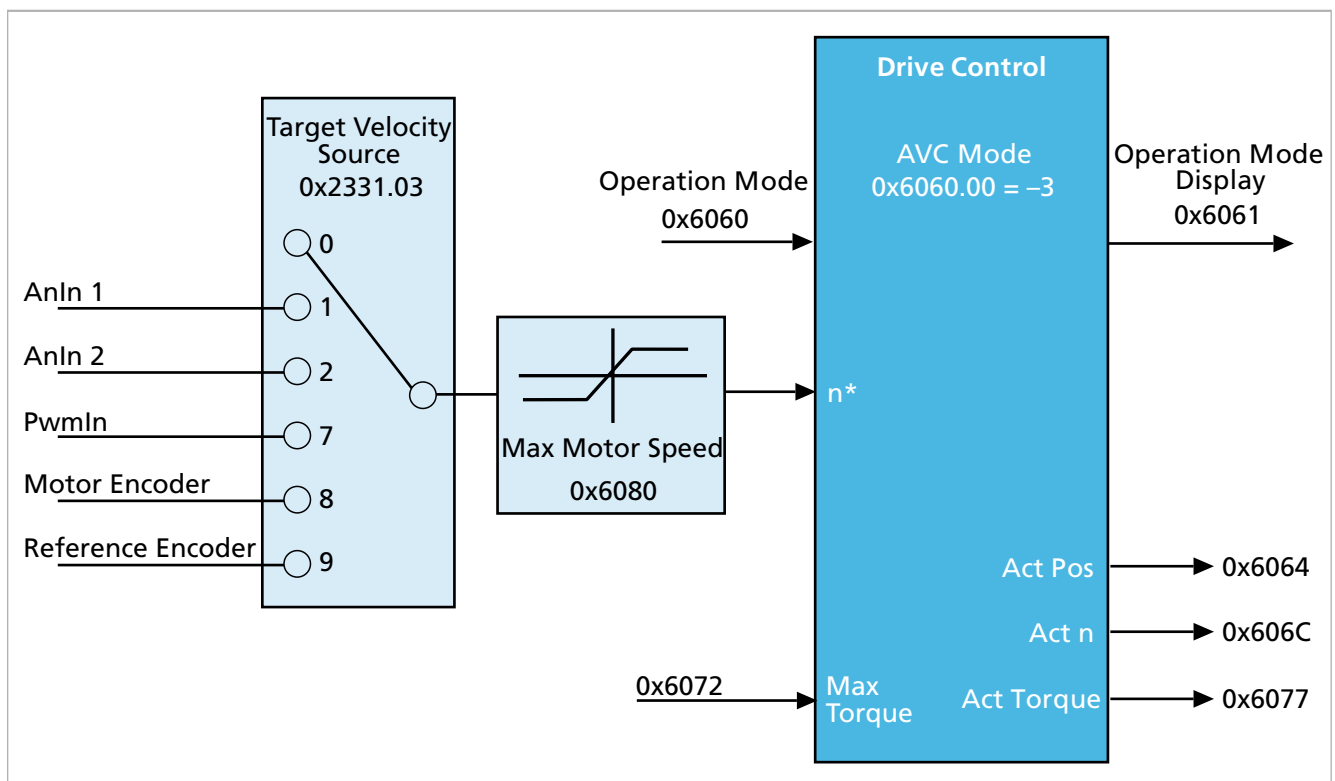

Fig. 63: Overview of Analog Velocity mode

#### Set-point specification and operation

If the output stage is activated, new set-points are applied immediately. The set-point must be specified for the controller in  $\text{min}^{-1}$ .

Tab. 62: Set-point sources

Sources	Set-point specification
<ul style="list-style-type: none"> <li>Analog input (AnIn 1 / AnIn 2)</li> <li>PWM input</li> </ul>	The scaling of the raw values must be adjusted to the value range of the control using the offset and gain parameters.
<ul style="list-style-type: none"> <li>Speed specification via a quadrature signal (motor encoder or reference encoder)</li> </ul>	A speed is calculated from the counted pulses using the resolution set on the motor encoder or on the reference encoder. No further conversion is performed.

## Selecting the operating mode

Tab. 63: Scaling of the set-point sources (see chap. 4.6, p. 49)

Input	Parameter
Analog inputs	Gain and offset in object 0x2313
PWM input	Gain and offset in object 0x2317
Quadrature signal via the motor encoder	IE resolution in object 0x2315
Encoder signal with BiSS-C or SSI protocol on motor encoder connection	Absolute encoder bits in object 0x2315
Quadrature signal via the reference encoder	IE resolution in object 0x2316
Position specification via a pulse/direction signal	IE resolution in object 0x2316

### Effective sub-functions

- Control of the speed via the controller according to chap. 4.3, p. 25
- Measurement of the actual values
- Monitoring of the movement for slippage
- Optional: Torque and speed limitation
- Estimate of the motor temperature and output stage temperature as a protective function
- Monitoring of the movement range via the Software Position Limits and limit switches

### 5.10.2 Controlword/statusword for Analog Velocity Control mode

In Analog Velocity Control mode there are no operating mode-specific bits in the controlword or statusword.

## Selecting the operating mode

### 5.10.3 Settings

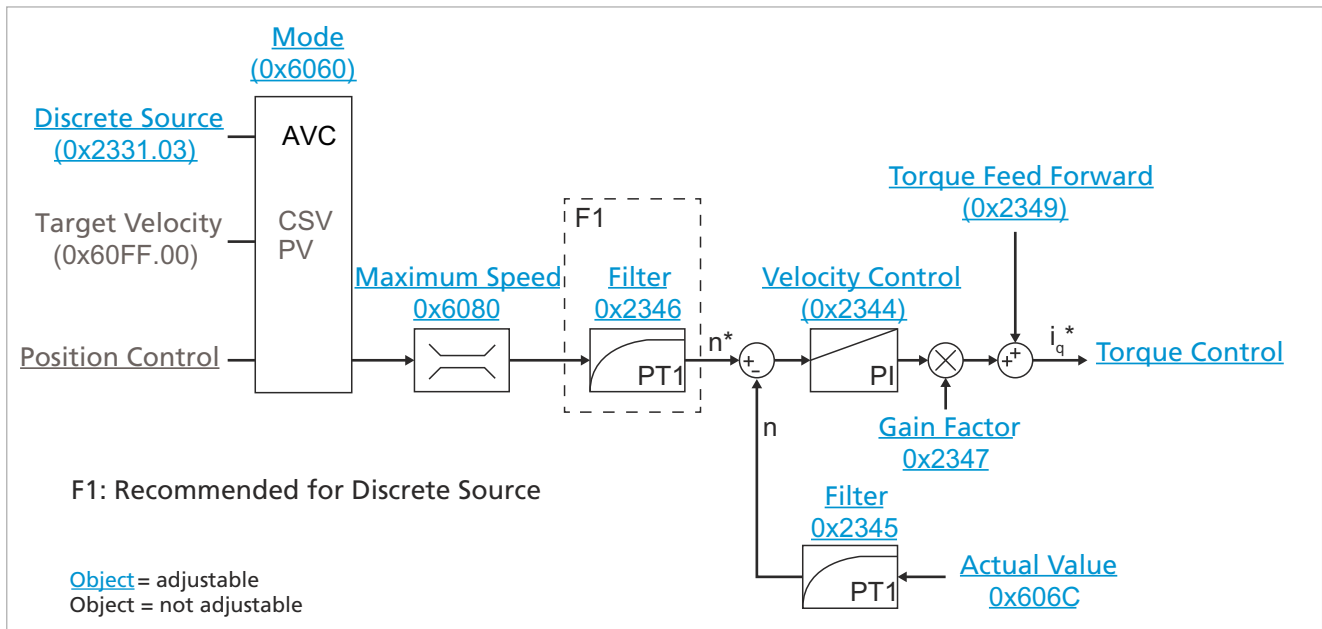

Fig. 64: Motion Manager view of the Analog Velocity Control mode

The following objects must be set when using this operating mode:

- Operation Mode (0x6060 = -3)
- Discrete Source for Reference Speed (0x2331.03)

### 5.10.4 Example

On a belt drive, the speed is to be specified via a potentiometer. The potentiometer is supplied with 5 V and connected to AnIn 1. The speed set-point is to be changed in the range 0...3000 min<sup>-1</sup> if the potentiometer is adjusted.

- ✓ Motor is selected via the Motion Manager
- ✓ Controller parameters are set acc. to chap. 4.3, p. 25
- ✓ AnIn 1 is selected as the set-point source for the speed with 0x2331.03 = 1
- ✓ Control is activated (the drive is in the *Operation Enabled* state)
- ▶ Scale AnIn 1 appropriately (see chap. 4.9, p. 75):
  - 0 V  $\triangleq$  0 min<sup>-1</sup> → Offset = 0
  - 5 V  $\triangleq$  3000 min<sup>-1</sup>
  - Gain = 3000/5000

$$\text{set-point} = (\{\text{raw value}\} + \text{offset}) * \text{Gain} = \{0...5000\} * \frac{3000}{5000}$$

- ▶ Select AVC operating mode with 0x6060.00 = -3.
- ↺ The drive moves to the speed set via the potentiometer.

## Selecting the operating mode

### 5.11 Analog Torque Control mode (ATC)

#### 5.11.1 Basic function

In the Analog Torque Control operating mode, the Motion Controller controls the force or torque of the drive. The set-point is specified via a discrete input. Profile parameters are not taken into account. The set-point is applied directly to the control.

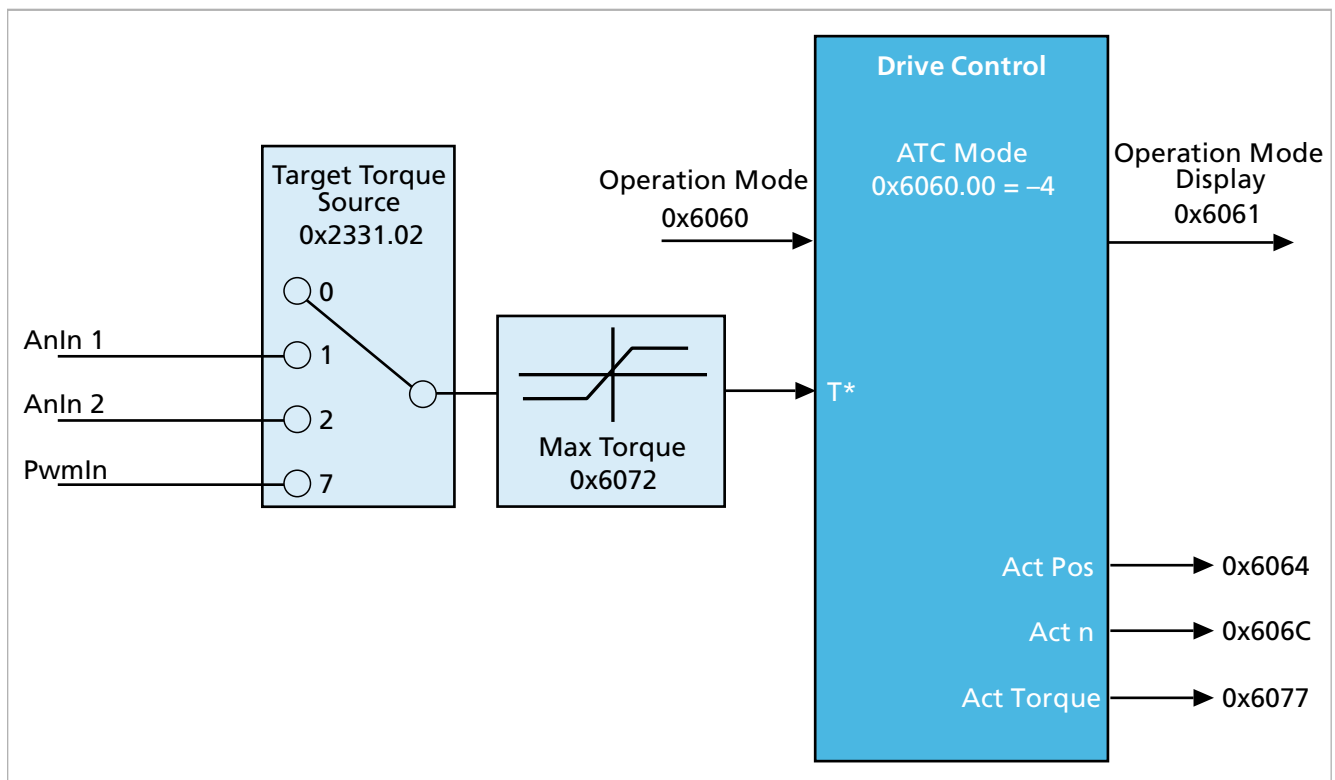

Fig. 65: Overview of Analog Torque Control mode

#### Set-point specification and operation

If the output stage is activated, new set-points are applied immediately. The set-point must be specified for the controller in  $I_N/1000$ , i.e., a set-point of 500 corresponds to 50% of the rated motor torque.

Tab. 64: Set-point sources

Sources	Set-point specification
<ul style="list-style-type: none"> <li>Analog input (AnIn 1 / AnIn 2)</li> <li>PWM input</li> </ul>	The scaling of the raw values must be adjusted to the value range of the control using the offset and gain parameters.

Tab. 65: Scaling of the set-point sources (see chap. 4.6, p. 49)

Input	Parameter
Analog inputs	Gain and offset in object 0x2313
PWM input	Gain and offset in object 0x2317

**i** The torque and force are controlled in the Motion Controller by the related motor current. A set-point of 1000 corresponds to the rated current of the motor. The input used as the set-point must be appropriately scaled for the purpose.

## Selecting the operating mode

### Effective sub-functions

- Control of the current via the controller according to chap. 4.3, p. 25
- Measurement of the actual values
- Optional: Torque and force limitation
- Estimate of the motor temperature and output stage temperature as a protective function
- Monitoring of the movement range via the Software Position Limits and limit switches

### 5.11.2 Controlword/statusword for Analog Torque Control mode

In Analog Torque Control mode there are no operating mode-specific bits in the controlword or statusword.

### 5.11.3 Settings

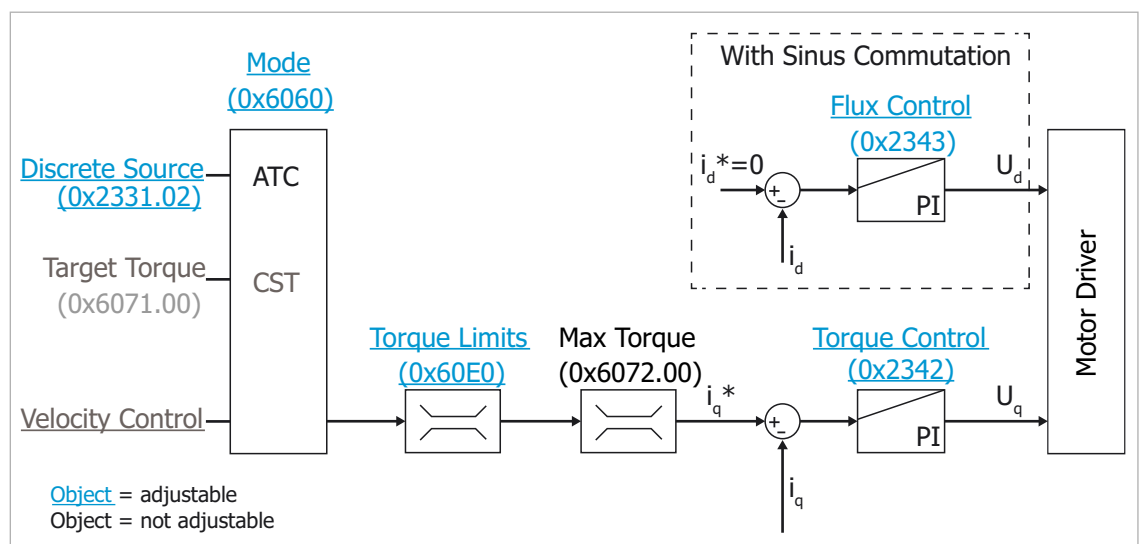

Fig. 66: Motion Manager view of the Analog Torque Control mode

The following objects must be set when using this operating mode:

- Operation Mode (0x6060 = -4)
- Discrete Source for Reference Current (0x2331.02)

## Selecting the operating mode

### 5.11.4 Example

The pulling force is to be set on a winding drive via a potentiometer. The potentiometer is supplied with 5 V and connected to AnIn 1. The pull torque is to be changed between 0 and 80% of the rated motor torque. The speed is to be monitored for the case of a tear.

- ✓ Motor is selected via the Motion Manager
- ✓ Controller parameters are set acc. to chap. 4.3, p. 25
- ✓ AnIn 1 is selected as the set-point source for the current with  $0x2331.02 = 1$
- ✓ Limit speed is set as Velocity Warning Threshold in  $0x2344.05$
- ✓ Error response (e.g., shutdown) is selected as the response to the dynamic limit error in  $0x2320$  via the masks in  $0x2321$ .
- ✓ Control is activated (the drive is in the *Operation Enabled* state)
- ▶ Scale AnIn 1 appropriately (see chap. 4.9, p. 75):
  - $0\text{ V} \triangleq 0\% \rightarrow \text{Offset} = 0$
  - $5\text{ V} \triangleq 80\% = 800$
  - $\text{Gain} = 800/5000$
$$\text{set-point} = (\{\text{raw value}\} + \text{offset}) * \text{Gain} = \{0\dots5000\} * \frac{800}{5000}$$
- ▶ Select ATC operating mode with  $0x6060.00 = -4$ .
- ↩ The drive adjusts the force or the torque to the value set with the potentiometer.

## Protection and monitoring devices

### 6 Protection and monitoring devices

FAULHABER Motion Controllers have a range of protective safeguards for the output stage and the connected motor:

- Thermal models for the connected motor and output stage
- Current and torque limitation via the current controller
- Overvoltage control in braking mode
- Undervoltage monitoring

#### 6.1 Overtemperature protection

Small drives generally have no sensors for the winding temperature. In order to protect the motor against overloading, allowing the full dynamics of the motor, the current is controlled accordingly.

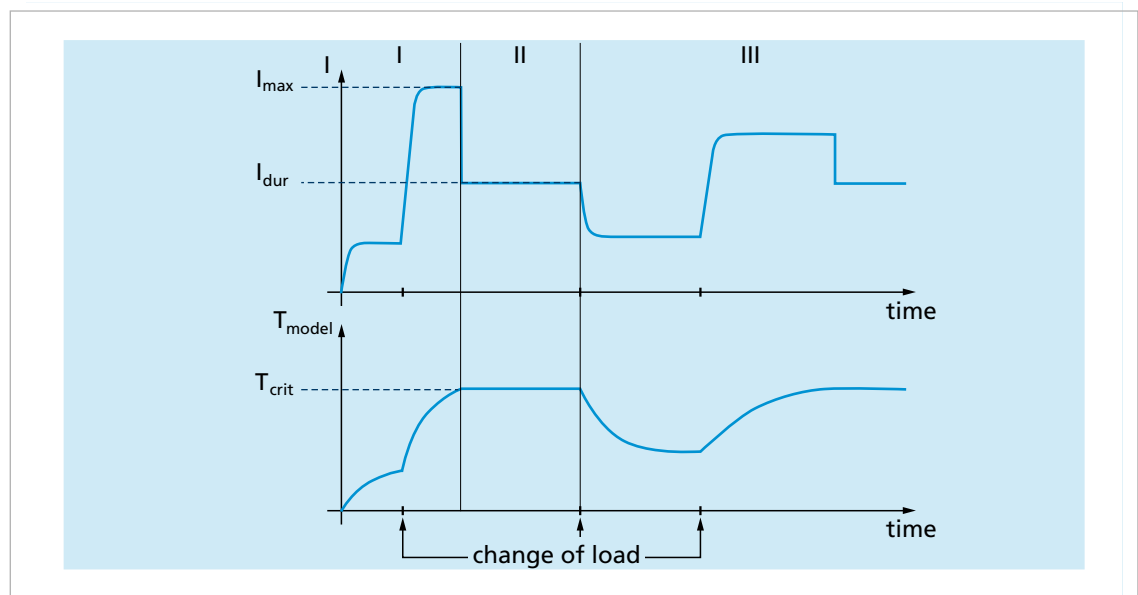

Fig. 67: Functionality of the  $I^2t$  current limitation

Area	Description
I	When the motor is cold, the current set-points are initially limited to the specified peak current.
II	A thermal model constantly determines a model temperature for the motor winding and the output stage from the currently flowing current. If one of these model temperatures exceed a critical value, the drive switches to the continuous current and the motor current is limited to this.
III	Only when the load is so low that the critical model temperature is no longer exceeded, the peak current is once again enabled. If the model temperature exceeds the critical value once again, the drive reverts to the continuous current.

**i** At room temperature the peak current in S2 mode is typically available for several 100 ms (see device data sheet).



## Protection and monitoring devices



### CAUTION!

Depending on the installation situation and the ambient temperature, the motor winding temperature calculated by the Motion Controller can vary from the actual temperature.

- ▶ If necessary, reduce the permissible continuous current for the motor below the value on the datasheet.
- ▶ Touch the motor only when wearing protective clothing.



### NOTICE!

If the continuous current of the motor is not configured to match the installation situation, the motor can overheat and the windings be damaged.

- ▶ Configure the data for the thermally permissible continuous current and the reduction of the thermal resistance in accordance with the installation situation.
- The measured or estimated temperatures, together with the respective limit values are summarized in the object 0x2326.
- The model parameters for the motor can be found in the object 0x232A. For Motion Controllers, the model parameters are written by the Motion Manager motor selection wizard; for drives with integrated electronics (Motion Control Systems) these values are pre-set by the factory.
- The following parameters allow the motor data to be adapted to the installation situation.
  - Ambient temperature (0x232A.08)
  - Reduction of the thermal resistance (0x232A.09) arising from the installation
  - Thermally permissible continuous current (0x2329.02)



Depending on the installation situation it may be necessary to enter in the object 0x2329.02 a value for the thermally permissible continuous current different to the value listed in the motor datasheet. Permissible in a specific application is a current which does not lead to an overheated motor or (integrated) electronics. Therefore, if the thermal coupling is good, it may be possible to tolerate a continuous current higher than that listed in the datasheet. In unfavorable installation situations the continuous current may also be lower than that listed in the datasheet.

Temperatures exceeding the warning and limit temperatures are signaled in the device statusword. As soon as one of the estimated temperatures exceeds the warning threshold set by the values in the object 0x2326, the limit value for the current controller is additionally limited to the thermally permissible continuous current. The full range of dynamic behavior is not available again until the drive has cooled down sufficiently.

## 6.2 Force or torque limitation

The current controller of the Motion Controller allows the torque output by a motor or the force output by a linear motor to be limited. Thus gearhead input stages can be protected against overloading.

To limit the current, the set-point of the current controller can be limited in a positive or negative direction via the objects 0x60E0 and 0x60E1.

## Protection and monitoring devices

### 6.3 Checking the power supplies

The electronics power supply and motor supply of the FAULHABER Motion Controller are monitored continuously.

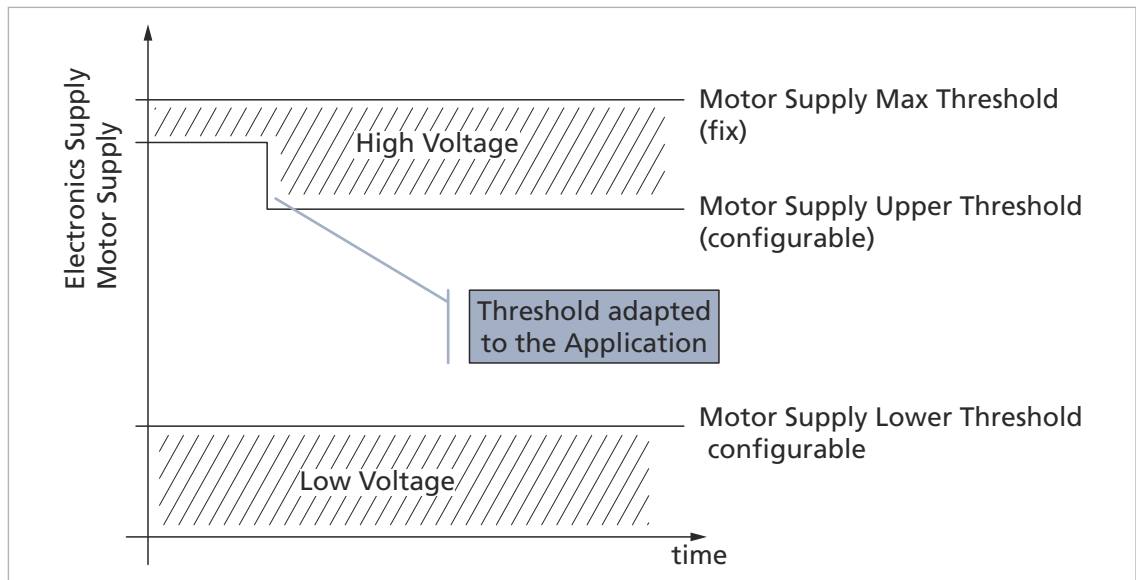

Fig. 68: Checking the power supplies

The limit values and the current values for the power supplies can be found in the object 0x2325:

- The maximum upper threshold (0x2325.03) and the minimum voltage for the electronics power supply (0x2325.01) are specified as fixed values.
- The lower threshold for the motor supply (0x2325.02) can be adapted to the application (see chap. 6.3.1, p. 155).
- A delay time for error detection can be adjusted using the object 0x2325.05 (chap. 6.3.1, p. 155).
- The upper threshold for the motor supply (0x2325.04) is variable and can be raised to the maximum voltage.
- If the power supply at the start of monitoring is already above the upper limit or below the lower limit, the change of state into the *Operation Enabled* state will not be performed.
- In dynamic operation it may occur that due to the regeneration of energy in braking mode the power supply rises above the limit value defined by the upper threshold. In this case the overvoltage controller is activated and, if necessary, the braking power is reduced (chap. 6.3.2, p. 155).

FAULHABER Motion Controllers MC 5010, MC 5005 and MC 5004 are equipped with a Power Good LED. As long as the monitored voltages lie within the set limits, the LED lights up green.

If the power supply remains outside the permissible ranges for longer than specified in the delay time, the relevant status bit is set in the device statusword. The Power Good LED no longer illuminates.

## Protection and monitoring devices

### 6.3.1 Undervoltage monitoring

If the electronics power supply voltage of the Motion Controller falls below the lower limit set in the object 0x2325.01, an error is signaled in bit 19 of the device statusword (0x2324.01) and the output stage is immediately switched off. There is no automatic restart.

The lower threshold for the motor supply is stated in object 0x2325.02. If the voltage at the connection for the motor supply falls below this value for longer than the waiting time stated in object 0x2325.05, an undervoltage error for the motor supply is signaled in bit 20 of the device statusword (0x2324.01). As for an undervoltage at the electronics power supply, the output stage is immediately switched off starting from firmware version K2.

 If the object 0x2325.02 lists 0 V as the undervoltage limit the motor supply is not monitored for undervoltage.

### 6.3.2 Overvoltage control

If the drive is in braking mode or generator mode, energy is fed back into the electrical mains. Usually the power supply units are not in a position to accept this energy. For this reason, in such circumstances the power supply can rise.

To avoid damage to components, FAULHABER Motion Controllers for brushless motors are equipped with a controller which adjusts the rotor displacement angle when the limit voltage set in the object 0x2325.04 is exceeded. In addition the braking power for all types of motor is reduced as necessary.



#### NOTICE!

**Using the default settings, the FAULHABER Motion Controller does not limit the regenerated energy until the default value for the upper limit has been exceeded. Therefore, for Motion Controllers with a permissible maximum voltage of 50 V, voltage peaks up to 50 V can be tolerated without affecting the dynamic behavior. If the drive is operating on a 24 V power supply system, this can lead to malfunctions by additional connected devices and even cause them irreparable damage.**

- ▶ Set the upper limit for the power supply to a lower value.



In order to be able to use the full dynamic response of the motor even in braking mode, when the load to be moved is large, a brake chopper should be connected to the DC power supply in parallel with the Motion Controller.

## 7 Diagnosis

### 7.1 Device monitoring

The diagnostic component of the FAULHABER Motion Controller monitors the device state on a cyclical basis.

The monitoring includes:

- Power supplies
- Temperatures
- Dynamic drive state

The results of the checks are stored as bits in the device statusword 0x2324.01. In addition, signals such as the state of the limit switches can also be evaluated centrally by means of the device statusword.

The device statusword can be queried by the communications interface. In addition selected statuses can also be signaled by a selectable digital output.

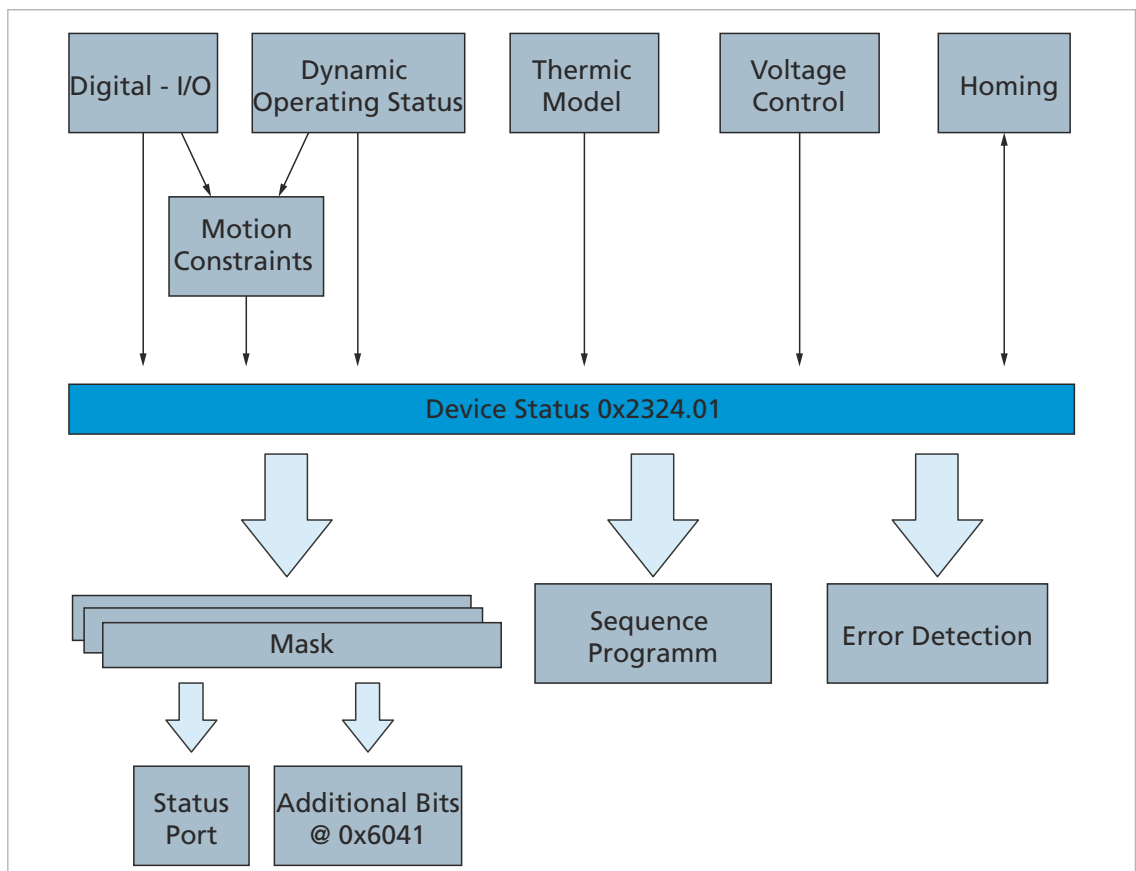

Fig. 69: Diagram of the device statusword

**i** The statuses of the first 8 digital inputs of the Motion Controller are displayed in the upper 8 bits of the device statusword. This allows the sequence program to respond easily to a change of state of one of the inputs.

## Diagnosis

### 7.1.1 Device statusword 0x2324.01

Tab. 66: Meaning of the entries of the device statusword

Bit	Mask	Meaning	Description
0	0x 00 00 00 01	n=0 monitoring	The actual speed lies within the speed corridor around the 0.
1	0x 00 00 00 02	Target Speed reached	The actual speed lies within the speed corridor around the target speed (evaluated only in the PV operating mode).
2	0x 00 00 00 04	Speed deviation lies outside the corridor	The control deviation of the speed controller (set-point – actual value) lies outside the corridor defined by 0x2344.03 and 0x2344.04 (blockage detection).
3	0x 00 00 00 08	Target Position reached	The actual position lies within the position corridor around the target position (evaluated only in the PP operating mode).
4	0x 00 00 00 10	Position has crossed the set-point	The actual position has crossed the target position (evaluated only in the PP operating mode).
5	0x 00 00 00 20	Following error outside the corridor	The control deviation of the position controller (set-point – actual value) lies outside the corridor defined by 0x6065 and 0x6066.
6	0x 00 00 00 40	Positive Limit Switch active	The positive limit switch is active.
7	0x 00 00 00 80	Negative Limit Switch active	The negative limit switch is active.
8	0x 00 00 01 00	Positive Software Position Limit reached	The actual position is greater than or equal to the positive software position limits.
9	0x 00 00 02 00	Negative Software Position Limit reached	The actual position is greater than or equal to the negative software position limits.
10	0x 00 00 04 00	Reference input detected <sup>a)</sup>	The configured reference input was detected.
11	0x 00 00 08 00	Encoder index detected <sup>a)</sup>	The configured encoder index was detected.
12	0x 00 00 10 00	The drive is referenced	The drive has performed at least one successful reference run.
13	0x 00 00 20 00	Voltage Limited	The controller is at the voltage limit (output limited).
14	0x 00 00 40 00	Torque Limited	The controller is at the current limit (set-point limited).
15	0x 00 00 80 00	Speed Limited	The controller is at the speed limit (set-point limited).
16	0x 00 01 00 00	Temperature warning limit reached	One of the monitored temperatures has exceeded the warning limit. The set-point of the current controller will be set to the continuous current of the motor.
17	0x 00 02 00 00	Temperature switch-off limit reached	One of the monitored temperatures has exceeded the switch-off threshold.
18	0x 00 04 00 00	Power supply too high	One of the monitored voltages has exceeded the upper threshold: <ul style="list-style-type: none"> <li>▪ Electronics power supply &gt; max threshold</li> <li>▪ Motor supply &gt; upper threshold</li> </ul> The overvoltage controller may have tripped.
19	0x 00 08 00 00	Electronics power supply too low	The electronics power supply lies below the lower threshold set in 0x2325.01.
20	0x 00 10 00 00	Motor supply too low	The motor supply lies below the lower threshold set in 0x2325.02.
21	0x 00 20 00 00	Speed error	The speed is higher than the maximum motor speed set by 0x2344.05.

## Diagnosis

Bit	Mask	Meaning	Description
22	0x 00 40 00 00	Safety monitor	Status of the STO monitoring in drives with STO function
23	0x 00 80 00 00	Reserved	-
24	0x 01 00 00 00	DigIn01	DigIn01
25	0x 02 00 00 00	DigIn02	DigIn02
26	0x 04 00 00 00	DigIn03	DigIn03
27	0x 08 00 00 00	DigIn04	DigIn04
28	0x 10 00 00 00	DigIn05	DigIn05
29	0x 20 00 00 00	DigIn06	DigIn06
30	0x 40 00 00 00	DigIn07	DigIn07
31	0x 80 00 00 00	DigIn08	DigIn08

a) *evaluation only during active reference run*

### 7.1.2 Status port

Any desired configurable combination of status bits can be signaled via a digital output of the Motion Controller. For this purpose a maximum of 4 ports can be defined in the object 0x2312.

One of the digital outputs of the device is switched if the respective pin is selected. If a 0 is entered as a pin, the function of that port is switched off.

The mask allows definition of which bits in the device statusword are to be evaluated. The selected output is set if the bit-based combination of the mask configured for the port and the device statusword yields at least one set status bit.

Output = (mask & device statusword) > 0 (bit-based link)

Parameter	Port 1	Port 2	Port 3	Port 4
Pin selection	0x2312.08	0x2312.0A	0x2312.0C	0x2312.0E
Mask (U 32)	0x2312.09	0x2312.0B	0x2312.0D	0x2312.0F

### 7.1.3 Additional bits in Statusword 0x6041

Instead of digital outputs, bits 14 and 15 in the Statusword of the device control (0x6041) can be used to signal selected device states. The evaluation logic corresponds to the status ports:

The additional bit is set if the bit-based combination of the mask configured for the port and the device statusword yields at least one set status bit.

Additional bit = (mask & device statusword) > 0 (bit-based link)

Otherwise the additional bit is reset.

Parameter	Statusword Bit 14	Statusword Bit 15
Mask (U 32)	0x233A.01	0x233A.02

# Diagnosis

## 7.2 Error handling

FAULHABER Motion Controllers and Motion Control Systems have two mechanisms available for error handling:

- Error handling according to CiA 402 (servo drive profile):  
Permits response to communication errors in CANopen and EtherCAT networks. If communication is absent or malfunctioning, the drive can be stopped or switched off.  
In the Communication Settings of the object 0x2400.04, it is additionally set whether one of the available buses should be monitored for errors or not.
- FAULHABER error word 0x2320:  
Permits response both to communication errors and to device faults or application errors.

### Response to communication errors

The following table shows the errors to which the two error handling mechanisms permit a response.

Error type	Error	Error handling acc. to CiA 402 <sup>a)</sup>	FAULHABER error word 0x2320 <sup>b)</sup>
Protocol errors	PDO with the wrong length	–	✓
Low-level errors	Bus off	✓	✓
	Buffer overflow	–	✓
Unexpected change of state	Exit the <i>Operational</i> state	✓	–
Guarding or heartbeat errors	–	✓	✓

a) To determine the response according to CiA 402 see chap. 7.2.1, p. 160

b) To determine the response according to the FAULHABER error word see chap. 7.2.2, p. 161

## Diagnosis

### 7.2.1 Error handling to according CiA 402 (servo drive profile)

For drives according to CiA 402 servo drive, the response to a communication error can be specified via object 0x6007.00.

Value	Response to communication errors
0	No response. The drive continues to advance to the current set-point.
1	<p>The drive switches into the error state of the CiA 402 drive state machine.</p> <ul style="list-style-type: none"> <li>▪ Depending on the settings in the object 0x605E (Fault Option Code) the drive can be brought to a controlled stop.</li> <li>▪ If a holding brake is configured, it is activated.</li> </ul>
2	<p>The drive switches into the <i>Switch on Disabled</i> state of the CiA 402 drive state machine. The change corresponds to the command <b>Disable Voltage</b>.</p> <ul style="list-style-type: none"> <li>▪ The drive is not brought to a stop, instead it coasts down.</li> <li>▪ If a holding brake is configured, it is activated.</li> </ul>
3	<p>Switch into the <i>Quick-Stop</i> state of the CiA 402 drive state machine. All outstanding movement jobs are discarded.</p> <p>The settings in the object 0x605A (Quick Stop Option Code) can be used to specify the following responses:</p> <ul style="list-style-type: none"> <li>▪ The drive is brought to a controlled stop.</li> <li>▪ The drive is then held in a controlled state at <math>n = 0</math> or after completion of the braking operation the output stage is switched off.</li> </ul>



## Diagnosis

### 7.2.2 Error handling with the FAULHABER error word

Errors are collected from the device diagnostics, the communications interface and the hardware drivers and combined in the FAULHABER error word (0x2320). The masks in object 0x2321 allow the definition of how the system responds to the errors that are detected.

Each error is additionally assigned an error code as listed in CiA 301/CiA 402, which is loaded in addition to an EMCY error message.

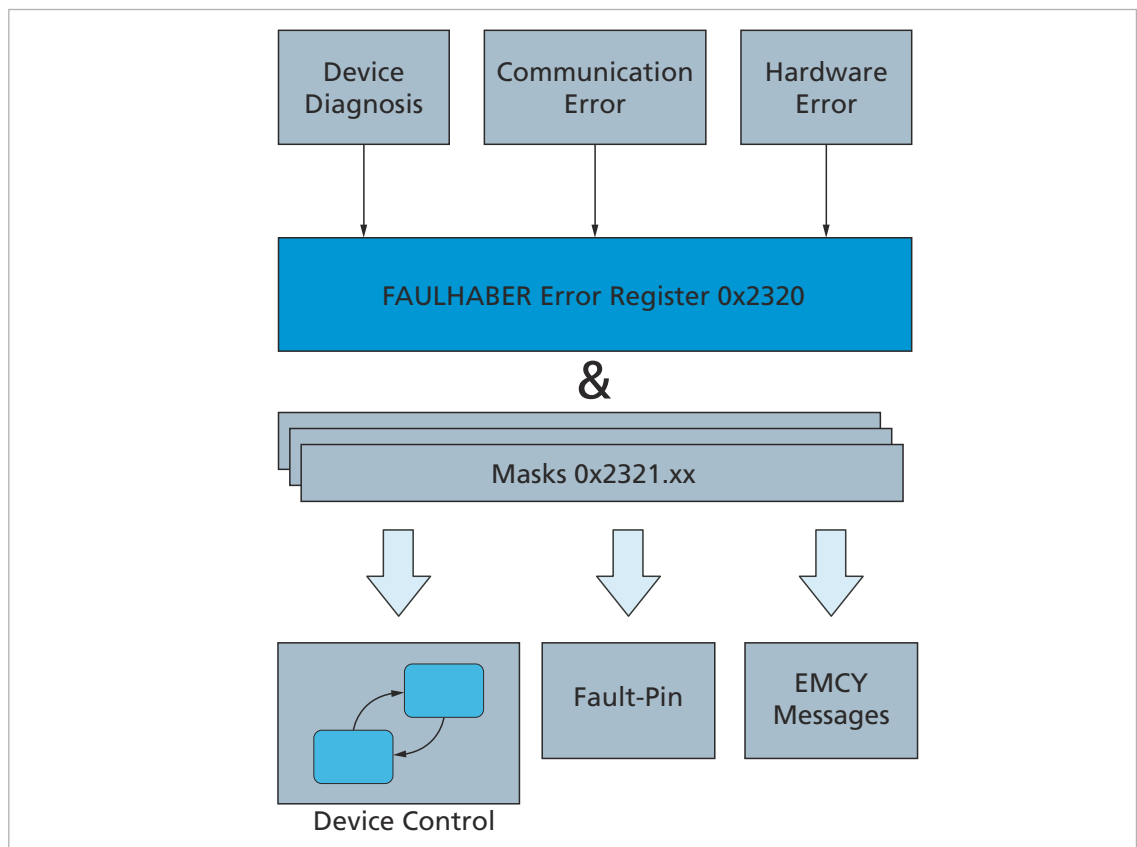

Fig. 70: Diagram of error detection

Tab. 67: Meaning of the entries of the FAULHABER error word and the corresponding CiA 402 error codes

Bit	Mask	Meaning	CiA 402 error code		Description
0	0x 00 01	SpeedDeviationError	0x84F0	SpeedDeviationError	Diagnostics detected a speed deviation. Monitoring is configured in object 0x2344.
1	0x 00 02	FollowingError	0x8611	FollowingError	Diagnostics detected a following error (deviation between position set-point and position actual value). The following error monitoring is configured via objects 0x6065 and 0x6066.
2	0x 00 04	OverVoltageError	0x3210	Overvoltage	Overvoltage for one of the supplies. The drive is switched off by this error.
3	0x 00 08	UnderVoltageError <sup>a)</sup>	0x3220	Undervoltage	At least one of the voltage supplies is reported as too low.
4	0x 00 10	TempWarning	0x2310	CurrentRefLimited	The current set-points are limited to the set continuous current by the thermal model.

## Diagnosis

Bit	Mask	Meaning	CiA 402 error code		Description
5	0x 00 20	TempError	0x4310	OverTempError	At least one of the temperature switch-off limits was reached. The drive is switched off by this error.
6	0x 00 40	Encoder error	0x7300	EncoderError	<ul style="list-style-type: none"> <li>Analog Hall: The amplitudes of the two or three Hall signals are not sufficiently equal for a period of time. This results in uneven running.</li> <li>Digital Hall: Invalid combination of Hall signals detected.</li> <li>AES encoder: CRC returns an error.</li> </ul>
7	0x 00 80	Int HW error	0x5410	OutputStage/DigOutError	At least one digital output does not have the expected level and was passively switched back.
8	0x 01 00	Reserved	–		
9	0x 02 00	Current Measurement Error	0x7200	CurrentMeasError	<p>Current measurement indicates an error. The current sum of the three channels is not equal to 0.</p> <p>Possible causes:</p> <ul style="list-style-type: none"> <li>Fault current via a winding-housing short circuit</li> <li>Motor and controller may not be compatible with respect to current measurement range and the rated current of the motor</li> </ul>
10	0x 04 00	Reserved	–		
11	0x 08 00	Com error	0x8110	CANOverrun	CAN reports an overflow of the receive buffer.
			0x8130	CANGuardingFailed	CAN node guarding or CAN heartbeat failed.
			0x8140	CANRecoveredFromBusOf f	After switching off temporarily, the CAN controller is again active on the bus.
			0x8141	CANBusOff	The CAN controller leaves the bus. Happens if too many error frames were received.
			0x8210	CANPDOLength	A PDO with a length not compatible with mapping was received.
			0x8310	RS232Overrun	The RS232 stack was not able to save a message.
			0x8101	CANInitError	CAN stack could not be started.
12	0x 10 00	Calc error	0xFF20	SoftwareError	Error in the execution of a BASIC script.
13	0x 20 00	Dynamic Limit	0x84FF	VelocitySpeedController	The speed was in excess of the warning threshold configured in object 0x2344.
14	0x 40 00	Safety monitor error	0x5480	OutputStageDeactivated	Shutdown of the output stage by the STO function.
15	0x 80 00	Reserved	–		
–	–	–	0x0000	noError	No error present

a) The shortfall below the lower threshold of the motor supply is monitored only if a value > 0 V is entered as the threshold in the object 0x2325.02.

## Diagnosis

Tab. 68: Overview of settings for the error response

Object	Mask
0x2321.01	Emergency mask: identifies errors for which an EMCY message is to be sent. Default: 0xFFFF
0x2321.02	Error mask: identifies errors for which the drive is switched into the <i>Fault</i> state of the drive state machine. Default: 0x0000
0x2321.03	Fault pin mask: identifies errors for which the fault pin is to be activated. Default: 0x0000
0x2321.04	Disable voltage factory mask: identifies errors for which the drive must be switched off without switching to the fault state. The Disable Voltage Factory Mask cannot be changed by the user, and takes effect in the event of overvoltage errors and temperature errors Default: 0x4024 For drives with safe shutdown (STO), the output stage is also forcibly blocked on the software side in the event of an STO error as well.
0x2321.05	Disable voltage mask: identifies errors for which the drive is to be switched off without switching to the fault state. The disable voltage mask can be changed by the user. Default: 0x0000
0x2321.06	Quick stop mask: identifies errors for which the drive is to be switched into the <i>Quick Stop</i> state. The Quick Stop Option Code is respected.

### 7.2.2.1 Switching off the error response of the drive

For each error that is detected a check is made whether a response by the state machine of the drive should or must be generated.

The state is switched if the bit-wise AND link of the FAULHABER error word to the error mask defined in the object 0x2321 yields at least one match. For this purpose the check is performed in the following sequence:

Pri- ority	Description	Object	Default value
1	Disable voltage factory mask	0x2321.04	0x 40 24
2	Disable voltage mask	0x2321.05	0x 00 00
3	Quick stop mask	0x2321.06	0x 00 00
4	Error mask	0x2321.02	0x 00 00

 The disable voltage factory mask is pre-defined at the factory. In the following cases the drive is switched off:

- If one of the power supplies is above the threshold specified in object 0x2325.04 for longer than the tolerance time specified (object 0x2325.05).
- If the electronics power supply is below the threshold specified in object 0x2325.01 for longer than the tolerance time specified (object 0x2325.05).
- If one of the monitored temperatures exceeds the switch-off threshold.
- If one of the power supplies exceeds the maximum value for the power supply (object 0x2325.03) by more than 30%.
- In drives with STO function, if the output stage was switched off via the STO function.

In these cases the drive is brought to a standstill, no longer following a ramp. If a holding brake is configured, it is activated.

## Diagnosis

---

 If an error which causes the drive to be switched off is present the drive cannot be enabled (see the following example).

### Example

- ✓ Undervoltage is configured as an error and should cause the drive to be switched off (disable voltage mask).
- ✓ The motor supply is less than the configured lower threshold.
- ↪ The drive cannot be switched on as long as the undervoltage remains detected.

### 7.2.2.2 Setting the error response fault pin

The fault pin mask in the object 0x2321.03 allows selection of the detected errors for which the fault pin should be set. In the default setting no errors are signaled at the fault pin.

 The digital output that is used as the fault pin can be configured via the object 0x2312.01. The factory default is that there is no pre-configured fault pin.

## Diagnosis

### 7.3 Dispatching error messages

Error messages contain:

- The error register 0x1001
- The CiA error code
- The FAULHABER error register 0x2320

The emergency object informs other bus participants of errors asynchronously without requiring a query. The emergency object's size is always 8 bytes:

8 bytes user data							
Error0(LB)	Error1(HB)	Error-Reg	FE0 (LB)	FE1 (HB)	0	0	0



Assignment of user data:

- Error0(LB)/Error1(HB): 16-bit error code
- Error-Reg: Error register (contents of object 0x1001, see chap. 7.3.1, p. 166)
- FE0(LB)/FE1(HB): 16-bit FAULHABER error register (contents of object 0x2320, see chap. 7.3.1, p. 166)
- Bytes 5 to 7: unused (0)

The error register identifies the error type. The individual error types are bit-coded and are assigned to the respective error codes. The object 0x1001 contains the last value of the error register.

The emergency object is described in detail in the communications manual.

The EMCY mask in the object 0x2321.01 allows selection of which of the detected errors triggers the sending of an error message via the communications system. The default setting is that every detected error triggers a message.

-  Error messages are sent out asynchronously without being explicitly requested by the higher-level control system. The message type used depends on the communications system. The options for the communications interfaces (object 0x2400.04) allow selection of the interfaces via which an asynchronous message is to be sent.
-  If RS232 net mode is activated, no asynchronous messages can be sent via the RS232 interface. No further error messages are transmitted automatically via the RS232 interface.

## Diagnosis

### 7.3.1 Error register 0x1001 and error log 0x1003

The assignment of the error register is specified by CiA 301.

#### Error register (0x1001)

Bit	Meaning	Assignment of the FAULHABER error word (0x2320) to the bits in the error register (0x1001)
0	Generic	Bit 0 will be set to 1 if a further error is signaled.
1	Current error	Bit 4: TempWarning
2	Voltage error	Bit 2: OverVoltageError or Bit 3: UnderVoltageError
3	Temperature error	Bit 5: TempError
4	Error from a communications stack	Bit 11: Com error
5	Drive-specific error	Bit 0: SpeedDeviationError or Bit 1: FollowingError
6	Not used	-
7	Manufacturer-specific error	All HW errors (bit 6 ... bit 9, bit 12 and bit 13)

#### Pre-defined error field (0x1003)

The last 8 error messages (EMCY) are stored in the error log of the device and can be read via the object 0x1003. The number of messages held in the error log can be viewed via the entry 0x1003.00.

## Diagnosis

### 7.3.2 Communication Settings

Object 0x2400.04 in the communication settings can be used to define what message types should be sent via each of the various interfaces.

Index	Byte 3	Byte 2	Byte 1	Byte 0
0x2400.04	Reserved	RS232 settings	USB settings	CANopen settings

The communication settings are bit-coded:

Code	Designation	Description
0x00 00 00 01	CAN-NMT mandatory	The drive function can be started only when the CANopen or EtherCAT interface has reached the <i>Operational</i> state via its network management (NMT). The loss of communications can then be handled as an error within the error response procedure according to CiA 402.
0x00 00 00 02	Transmit async PDOs and EMCYs via CAN	Controls the transmission of asynchronous messages at changes of state in the CiA 402 drive state machine and the transmission of EMCY messages.
0x00 00 01 00	Transmit EMCYs via USB	Controls the transmission of error messages via the USB interface.
0x00 00 02 00	Transmit async messages via USB	Controls the transmission of asynchronous messages at changes of state of the CiA 402 drive state machine via the USB interface.
0x00 00 80 00	Suppress boot message via USB	Controls the sending of the boot message via the USB interface.
0x00 01 00 00	Transmit EMCYs via RS232	Controls the transmission of error messages via the RS232 interface. No error messages are transmitted if the drive is in net mode (several drives at one RS232 interface).
0x00 02 00 00	Transmit async messages via RS232	Controls the transmission of asynchronous messages at changes of state of the CiA 402 drive state machine via the RS232 interface. No asynchronous messages are transmitted if the drive is in net mode (several drives at one RS232 interface).
0x00 80 00 00	Ignore CRC	The CRC code is not evaluated if messages are received. The setting serves to simplify commissioning on third-party controls.

 The settings at object 0x2400.04 are effective for both error handling mechanisms.

## 7.4 Indication of the dynamic state via the status LED

The dynamic state of the drive is signaled by the status LED.

Tab. 69: Available displays of the status LED

Color	State	Meaning
Green	Flashing	The drive is ready. However the state machine has not yet reached the <i>Operation Enabled</i> state. The controller and output stage are switched off.
Green	Continuously lit	The drive is ready, the output stage is switched on.
Red	Continuously flashing	The drive has switched to a fault state. The output stage will be switched off or has already been switched off.
Red	Flash code	Boot procedure failed. Please contact FAULHABER Support.
Red	Continuously lit	The device is in boot loader mode.

## Parameter description

### 8 Parameter description

#### 8.1 Manufacturer-specific objects

##### Number of I/Os (0x2300)

Index	Subindex	Name	Type	Attr.	Default value	Meaning
0x2300	0x00	Number of Entries	U8	ro	4	Number of object entries
	0x01	Number of Digital Inputs	U8	ro		Number of digital inputs
	0x02	Number of Digital Outputs	U8	ro		Number of digital outputs
	0x03	Number of Analog Inputs	U8	ro		Number of analog inputs
	0x04	Number of Emulated Digital Inputs	U8	rw	0	Number of emulated digital inputs

##### Digital Input Settings (0x2310)

Index	Subindex	Name	Type	Attr.	Default value	Meaning
0x2310	0x00	Number of Entries	U8	ro	18	Number of object entries
	0x01	Select Lower Limit Switch Inputs	U8	rw	0	Selection of the lower limit switch
	0x02	Select Upper Limit Switch Inputs	U8	rw	0	Selection of the upper limit switch
	0x03	Limit Switch Option Code	S16	rw	2	Limit Switch Option Code
	0x04	Select Reference Switch Input	U8	rw	0	Determine the digital input of the reference switch
	0x05	Emulated Input Threshold Level	U8	rw	0	Bit-coded, see chap. 4.10.2, p. 86
	0x10	Input Polarity	U8	rw	0	Polarity of the inputs
	0x11	Input Threshold Level	U8	rw	0	Set the switching level for all digital inputs: <ul style="list-style-type: none"> <li>▪ 0: 5V-TTL</li> <li>▪ 1: 24V-PLC</li> </ul>
	0x12	Input Filter Active	U8	rw	0	Bit-coded for 8 inputs. <ul style="list-style-type: none"> <li>▪ 0: No edge filter for the input</li> <li>▪ 1: Edge filter for the input active</li> </ul>

Settings of the digital inputs in accordance with the bit mask in Tab. 1



## Parameter description

### Digital I/O Status (0x2311)

Index	Subindex	Name	Type	Attr.	Default value	Meaning
0x2311	0x00	Number of Entries	U8	ro	4	Number of object entries
	0x01	Digital Input Logical State	U8	ro	0	Logical states of the digital inputs
	0x02	Digital Input Physical State	U8	ro	0	Physical states of the digital inputs
	0x03	Digital Output Status	U8	ro	0	Status of the digital output
	0x04	Write Digital Outputs	U16	rw	0	Directly setting, deleting, toggling digital outputs.

States of the digital inputs in accordance with the bit mask in Tab. 1

### Digital Output Settings (0x2312)

Index	Subindex	Name	Type	Attr.	Default value	Meaning
0x2312	0x00	Number of Entries	U8	ro	16	Number of object entries
	0x01	Select Fault Output Pin	U8	rw	0	Number of the digital output to be used as fault pin.
	0x02	Select Brake Control Pin	U8	rw	0	Number of the digital output to be used for actuation of a holding brake
	0x03	Brake Delay time	U8	rw	0	Braking deceleration
	0x08	DiagOutput 1 Pin Selection	U8	rw	0	See chap. 4.9.3.3, p. 79
	0x09	DiagOutput 1 Mask	U32	rw	0	See chap. 4.9.3.3, p. 79
	0x0A	DiagOutput 2 Pin Selection	U8	rw	0	See chap. 4.9.3.3, p. 79
	0x0B	DiagOutput 2 Mask	U32	rw	0	See chap. 4.9.3.3, p. 79
	0x0C	DiagOutput 3 Pin Selection	U8	rw	0	See chap. 4.9.3.3, p. 79
	0x0D	DiagOutput 3 Mask	U32	rw	0	See chap. 4.9.3.3, p. 79
	0x0E	DiagOutput 4 Pin Selection	U8	rw	0	See chap. 4.9.3.3, p. 79
	0x0F	DiagOutput 4 Mask	U32	rw	0	See chap. 4.9.3.3, p. 79
	0x10	Output Polarity	U8	rw	0	Polarity of the outputs

## Parameter description

### Analog Inputs (0x2313)

Index	Subindex	Name	Type	Attr.	Default value	Meaning
0x2313	0x00	Number of Entries	U8	ro	21	Number of object entries
	0x01	AnIn 1 Gain (Numerator/Divisor)	S32	rw	0x7FFF8000	AnIn 1 gain (numerator/denominator) <ul style="list-style-type: none"> <li>Bit 0...15: Numerator</li> <li>Bit 16...31: Denominator</li> </ul>
	0x02	AnIn 1 Offset	S16	rw	0	AnIn 1 offset
	0x03	AnIn 1 Filter Time	U16	rw	0	AnIn 1 filter time in 100 µs
	0x04	AnIn 1 User Scaled Value	S32	ro	-	Scaled AnIn 1 value
	0x05	AnIn 1 Resolution as Encoder	U16	rw	1000	AnIn 1 resolution of the encoder
	0x06	AnIn 1 Min Input Limit	S16	rw	-32768	AnIn 1 lower limit for the input value
	0x07	AnIn 1 Max Input Limit	S16	rw	32767	AnIn 1 upper limit for the input value
	0x08	AnIn 1 Select Dir Pin	U8	rw	0	AnIn 1 polarity input: 0: No polarity input used 1...8: Digital input used as polarity input
	0x09	AnIn 1 Virtual Input Value	S16	rw	0	AnIn 1 simulated input value
	0x0A	AnIn 1 Enable Virtual Input	U8	rw	0	AnIn 1 simulated input value activated
	0x11	AnIn 2 Gain (Numerator/Divisor)	S32	rw	0x7FFF8000	AnIn 2 gain (numerator/denominator) <ul style="list-style-type: none"> <li>Bit 0...15: Numerator</li> <li>Bit 16...31: Denominator</li> </ul>
	0x12	AnIn 2 Offset	S16	rw	0	AnIn 2 offset
	0x13	AnIn 2 Filter Time	U16	rw	0	AnIn 2 filter time in 100 µs
	0x14	AnIn 2 User Scaled Value	S32	ro	-	Scaled AnIn 2 value
	0x15	AnIn 2 Resolution as Encoder	U16	rw	1000	AnIn 2 resolution of the encoder
	0x16	AnIn 2 Min Input Limit	S16	rw	-32768	AnIn 2 lower limit for the input value
	0x17	AnIn 2 Max Input Limit	S16	rw	32767	AnIn 2 upper limit for the input value
	0x18	AnIn 2 Select Dir Pin	U8	rw	0	AnIn 2 polarity input: 0: No polarity input used 1...8: Digital input used as polarity input
	0x19	AnIn 2 Virtual Input Value	S16	rw	0	AnIn 2 simulated input value
	0x1A	AnIn 2 Enable Virtual Input	U8	rw	0	AnIn 2 simulated input value activated

## Parameter description

### Manufacturer Scaled Analog Input Values (0x2314)

Index	Subindex	Name	Type	Attr.	Default value	Meaning
0x2314	0x00	Number of Entries	U8	ro	12	Number of object entries
	0x01	AnIn 1 Scaled Value (IA)	S16	ro	-	Scaled value at input 1 (IA) <sup>a)</sup>
	0x02	AnIn 2 Scaled Value (IB)	S16	ro	-	Scaled value at input 2 (IB) <sup>a)</sup>
	0x03	AnIn 3 Scaled Value (IC)	S16	ro	-	Scaled value at input 3 (IC) <sup>a)</sup>
	0x04	AnIn 4 Scaled Value (Hall A)	S16	ro	-	Scaled value at input 4 (Hall A)
	0x05	AnIn 5 Scaled Value (Hall B)	S16	ro	-	Scaled value at input 5 (Hall B)
	0x06	AnIn 6 Scaled Value (Hall C)	S16	ro	-	Scaled value at input 6 (Hall C)
	0x07	AnIn 7 Scaled Value	S16	ro	-	Scaled value at input 7 (AnIn1)
	0x08	AnIn 8 Scaled Value	S16	ro	-	Scaled value at input 8 (AnIn2)
	0x09	AnIn 9 Scaled Value	S16	ro	-	Scaled value at input 9
	0x0A	AnIn 10 Scaled Value0	S16	ro	-	Scaled value at input 10
	0x0B	AnIn 11 Scaled Value	S16	ro	-	Scaled value at input 11
	0x0C	AnIn 12 Scaled Value	S16	ro	-	Scaled value at input 12

a) A value of 1000 corresponds to the device rated current set in object 2327.01

### Motor Encoder (0x2315)

Index	Subindex	Name	Type	Attr.	Default value	Meaning
0x2315	0x00	Number of Entries	U8	ro	9	Number of object entries
	0x01	Operation Mode	U16	rw	0	Selection of the encoder type
	0x02	IE Resolution	U32	rw	0x0800	Resolution as incremental encoder
	0x03	Motor Encoder Position (unscaled)	S32	ro		Actual value of the position without conversion
	0x04	Gain	S32	ro	0x40004000	Scaling as fraction numerator/denominator
	0x05	Motor Encoder Position (scaled)	S32	rw		Position after conversion
	0x06	Absolute Encoder Bits	U32	rw	0x000C	Resolution of the absolute encoder, specified as preceding, multiturn and singleturn bits
	0x07	Encoder Status	U8	ro	0	Status bits and CRC of a BiSS-C-based encoder

## Parameter description

### Reference Encoder (0x2316)

Index	Subindex	Name	Type	Attr.	Default value	Meaning
0x2316	0x00	Number of Entries	U8	ro	5	Number of object entries
	0x01	Operation Mode	U16	rw	0	Selection of the encoder type
	0x02	IE Resolution	U32	rw	2048	Resolution as incremental encoder
	0x03	Reference Encoder Position (unscaled)	S32	ro	0	Actual value of the position without conversion
	0x04	Gain	S32	rw	0x40004000	Scaling as fraction numerator/denominator
	0x05	Reference Encoder Position (scaled)	S32	rw	0	Position after conversion.

### PWM Input (0x2317)

Index	Subindex	Name	Type	Attr.	Default value	Meaning
0x2317	0x00	Number of Entries	U8	ro	7	Number of object entries
	0x01	Digital Input Pin	U8	rw	0	PWM input: 1: DigIn1 = PWM input 2: DigIn2 = PWM input
	0x02	PWM Input Frequency	U32	ro		Frequency of the PWM signal
	0x03	Duty Cycle Raw Value	S16	ro		Duty cycle of the PWM signal (unscaled)
	0x04	Duty Cycle Gain (Numerator / Divisor)	U32	rw	0x7FFF8000	PWM in gain (numerator/denominator)
	0x05	Duty Cycle Offset	S16	rw	0	PWM in offset
	0x06	Duty Cycle Scaled Value	S32	ro		Scaled pulse width
	0x07	Resolution As Encoder	S16	rw	1000	Resolution of the encoder

## Parameter description

### Analog Hall Configuration (0x2318)

Index	Subindex	Name	Type	Attr.	Default value	Meaning
0x2318	0x00	Number of Entries	U8	ro	4	Number of object entries
	0x01	Hall Sensor Type	U8	rw	0	Bit-coded selection of the sensor type (see chap. 4.6.3, p. 54)
	0x02	Enable Adaption	U8	rw	0	0: Adjustment switched off 1: Adjustment active
	0x03	Adaption Threshold Speed	U32	rw	1000	Minimum speed in [ $\text{min}^{-1}$ ], from which the Hall signals are adjusted.
	0x04	Digital Hall Settings of Non-Faulhaber Motors	8	rw	0	Bit 0: <ul style="list-style-type: none"> <li>▪ 0x00: Hall sequence A–C–B (FAULHABER)</li> <li>▪ 0x01: Hall sequence A–B–C</li> </ul> Bit 7: <ul style="list-style-type: none"> <li>▪ 0x00: Hall signals are evaluated directly</li> <li>▪ 0x80: Hall signals are inverted</li> </ul> See FAULHABER Product AppNote 155.

### Reduction Ratio, external position encoder (0x2319)

Index	Subindex	Name	Type	Attr.	Default value	Meaning
0x2319	0x00	Number of Entries	U8	ro	2	Number of object entries
	0x01	Numerator	U32	rw	1	Numerator of the reduction, e.g., 3696
	0x02	Divisor	U32	rw	1	Denominator of the reduction, e.g., 289

### FAULHABER Error Register (0x2320)

Index	Subindex	Name	Type	Attr.	Default value	Meaning
0x2320	0x00	FAULHABER Error Register	U16	ro	0	FAULHABER error word (see chap. 7, p. 156)

### Error Mask (0x2321)

Index	Subindex	Name	Type	Attr.	Default value	Meaning
0x2321	0x00	Number of Entries	U8	ro	6	Number of object entries
	0x01	Emergency Mask	U16	rw	0xFFFF	Errors for which an error message is sent
	0x02	Fault Mask	U16	rw	0x0000	Errors for which the state machine of the drive switches into <i>Fault Reaction Active</i> state
	0x03	Error Out Mask	U16	rw	0x0000	Errors for which the error output pin is set
	0x04	Disable Voltage Mask	U16	ro	0x4024	Errors which switch off the drive (not configurable)
	0x05	Disable Voltage User Mask	U16	rw	0x0000	Errors which switch off the drive (configurable)
	0x06	Quick Stop Mask	U16	rw	0x0000	Errors for which the state machine of the drive switches into <i>Quick Stop Active</i> state

## Parameter description

### Device Status (0x2324)

The current device state is monitored via the Device Status (0x2324) object.

Index	Subindex	Name	Type	Attr.	Default value	Meaning
0x2324	0x00	Number of Entries	U8	ro	1	Number of object entries
	0x01	Device Status Word	U32	ro	0	Device status
	0x02	Limit Check Delay Time	U16	rw	10	Delay time until blockage detection [ms]

### Voltage Monitor (0x2325)

Index	Subindex	Name	Type	Attr.	Default value	Meaning
0x2325	0x00	Number of Entries	U8	ro	7	Number of object entries
	0x01	Device Supply Lower Threshold	U16	ro	1200	Lower threshold value of the power supply of the device <sup>a)</sup>
	0x02	Motor Supply Lower Threshold	U16	rw	1200	Lower threshold value of the motor power supply <sup>a)</sup>
	0x03	Motor Supply Max Threshold	U16	ro	5200	Maximum threshold value of the motor power supply <sup>a)</sup>
	0x04	Motor Supply Upper Threshold	U16	rw	5200	Upper threshold value of the motor power supply <sup>a)</sup>
	0x05	Voltage Error Delay Time	U16	rw	200	Delay time in ms until a voltage error is signaled
	0x06	Device Supply Voltage	U16	ro	-	Current power supply of the electronics
	0x07	Motor Supply Voltage	U16	ro	-	Current power supply of the motor

a) All voltages are in 10 mV per digit

## Parameter description

### Device Temperature (0x2326)

Index	Subindex	Name	Type	Attr.	Default value	Meaning
0x2326	0x00	Number of Entries	U8	ro	9	Number of object entries
	0x01	CPU Temperature	S16	ro	0	Temperature of the processor [°C]
	0x02	Power Stage Temperature	S16	ro	0	Temperature of the output stage [°C]
	0x03	Winding Temperature	S16	ro	0	Temperature of the winding [°C]
	0x04	CPU Temperature Shutdown Threshold	S16	ro	115	Switch-off threshold temperature of the processor [°C]
	0x05	CPU Temperature Warning Threshold	S16	ro	105	Warning threshold temperature of the processor [°C]
	0x06	Power Stage Temperature Shutdown Threshold	S16	ro	140	Switch-off threshold temperature of the output stage [°C]
	0x07	Power Stage Temperature Warning Threshold	S16	ro	135	Warning threshold temperature of the output stage [°C]
	0x08	Winding Temperature Shutdown Threshold	S16	rw	125	Switch-off threshold temperature of the motor [°C]
	0x09	Winding Temperature Warning Threshold	S16	rw	115	Warning threshold temperature of the motor [°C]

### Device Data (0x2327)

Index	Subindex	Name	Type	Attr.	Default value	Meaning
0x2327	0x00	Number of Entries	U8	ro	3	Number of object entries
	0x01	Device Nominal Current	U16	ro	Device-specific	Nominal current at the Motion Controller
	0x02	Device Peak Current	U16	ro	Device-specific	Peak current of the device
	0x03	Device Nominal Voltage	U16	ro	Device-specific	Nominal voltage of the device

## Parameter description

### Device Data Thermal Model (0x2328)

Index	Subindex	Name	Type	Attr.	Default value	Meaning
0x2328	0x00	Number of Entries	U8	ro	9	Number of object entries
	0x01	Controller Type	U8	ro	Device-specific	0: No MCS 1: MCS
	0x02	Power Stage $R_{dson}$	U8	ro	Device-specific	On-state resistance of a MOSFET [mOhm]
	0x03	Power Stage LossFactor	U16	ro	Device-specific	Factor for internal calculation of the switching losses of the output stage
	0x04	Power Stage $R_{th1}$	U16	ro	Device-specific	Thermal resistance of the output stage
	0x05	Power Stage Time Constant 1	U16	ro	Device-specific	Time constant of the output stage
	0x06	Power Stage $R_{th2}$	U16	ro	Device-specific	Thermal resistance of the output stage
	0x07	Power Stage Time Constant 2	U16	ro	Device-specific	Time constant of the output stage
	0x08	Power Stage $R_{th3}$	U16	ro	Device-specific	Thermal resistance of the output stage
	0x09	Power Stage $R_{th4}$	U16	ro	Device-specific	Thermal resistance of the output stage



## Parameter description

### Motor- and Application Data / Motor Control (0x2329)

Index	Subindex	Name	Type	Attr.	Default value	Meaning
0x2329	0x00	Number of Entries	U8	ro	13	Number of object entries
	0x01	Rated Current	U16	rw	–	Rated current of the motor [mA]
	0x02	Continuous Current	U16	rw	–	Continuous current of the motor [mA]
	0x03	Peak Current	U16	rw	–	Peak current of the motor [mA]
	0x04	Torque Constant / Force Constant	U32	rw	–	<ul style="list-style-type: none"> <li>For rotating motors: Torque constant <math>k_m</math> [mNm/A <math>\times 1e^{-3}</math>]</li> <li>For linear motors: Force constant <math>k_f</math> [N/A <math>\times 1e^{-3}</math>]</li> </ul>
	0x05	Terminal Inductance	U16	rw	–	Connection inductance $L_A$ of the motor [ $\mu$ H]
	0x06	Inductance $L_d$	U16	rw	–	Longitudinal inductance $L_d$ of the motor [ $\mu$ H]; if not explicitly declared, set the longitudinal inductance to the same value as the terminal inductance
	0x07	Number of Pole Pairs	U8	rw	–	Number of pole pairs
	0x08	Phase Angle Offset	S16	rw	0	Phase angle offset, 32767 digits = 180° electrical
	0x09	Rotor Inertia / Rod weight	U32	rw	–	<ul style="list-style-type: none"> <li>For rotating motors: Mass inertia of the rotor <math>J_{Motor}</math> [<math>gcm^2 \times 1e^{-3}</math>]</li> <li>For linear motors: Mass of the forcer rod <math>m_{Motor}</math> [g]</li> </ul>
	0x0A	Load Inertia / Load Mass	U32	rw	–	<ul style="list-style-type: none"> <li>For rotating motors: Mass inertia of the load translated to the motor [<math>gcm^2 \times 1e^{-3}</math>]</li> <li>For linear motors: Mass of the load translated to the motor [g]</li> </ul>
	0x0B	Motor Type	U8	rw	0	0: Rotating motor 1: Linear motor (with forcer rod)
	0x0C	Magnetic Pitch of Linear Motor	U8	rw	–	Polar pitch of the linear motor [mm]
	0x0D	Filter phase inductance	U8	rw	0	Filter inductance per phase [ $\mu$ H]

## Parameter description

### Motor- and Application Data / Thermal Motor Model (0x232A)

Index	Subindex	Name	Type	Attr.	Default value	Meaning
0x232A	0x00	Number of Entries	U8	ro	9	Number of object entries
	0x01	Terminal Resistance	U32	rw	a)	Connection resistance R of the motor in mOhm
	0x02	Friction	U32	rw	a)	Friction torque [mNm x 1e <sup>-6</sup> ], corresponds to c0 for BL motors and MR for DC motors
	0x03	Friction, dynamic	U32	rw	a)	Dynamic friction torque cv [mNm/rpm x 1e <sup>-9</sup> ] (only for BL motors)
	0x04	Thermal Resistance 1	U16	rw	a)	Thermal resistance 1 of the motor [mK/W] (winding to housing)
	0x05	Thermal Resistance 2	U16	rw	a)	Thermal resistance 2 of the motor [mK/W] (housing to environment)
	0x06	Thermal Time Constant 1	U16	rw	a)	Thermal time constant 1 of the motor [s] (winding to housing)
	0x07	Thermal Time Constant 2	U32	rw	a)	Thermal time constant 2 of the motor [s] (housing to environment)
	0x08	Ambient Temperature	U8	rw	a)	Ambient temperature of the motor [°C]
	0x09	Reduction of Thermal Resistance 2	U8	rw	a)	Reduction of the thermal resistance 2 of the motor [%] (housing to environment)

a) Motor-specific, is set by the motor selection wizard

### Switch Position for Actual Values (0x2330)

Index	Subindex	Name	Type	Attr.	Default value	Meaning
0x2330	0x00	Number of Entries	U8	ro	3	Number of object entries
	0x01	Actual Commutation Angle Source	U8	rw	1	Commutation angle actual value source
	0x02	Actual Velocity Source	U8	rw	1	Speed actual value source
	0x03	Actual Position Source	U8	rw	1	Position actual value source

### Discrete Sources (0x2331)

Index	Subindex	Name	Type	Attr.	Default value	Meaning
0x2331	0x00	Number of Entries	U8	ro	4	Number of object entries
	0x01	Target Voltage Source	U8	rw	0	Selection of the discrete source for the voltage set-point
	0x02	Target Current Source	U8	rw	0	Selection of the discrete source for the torque set value
	0x03	Target Velocity Source	U8	rw	0	Selection of the discrete source for the speed set value
	0x04	Target Position Source	U8	rw	0	Selection of the discrete source for the position set-point

## Parameter description

### Cyclic mode interpolation rate (0x2332)

Index	Subindex	Name	Type	Attr.	Default value	Meaning
0x2332	0x00	Cyclic Mode Interpolation Rate	U16	rw	1	Controller interpolation rate in multiples of 100 $\mu$ s of the refresh rate of the master

### Manufacturer Specified Bits (0x233A)

Index	Subindex	Name	Type	Attr.	Default value	Meaning
0x233A	0x00	Number of Entries	U8	ro	2	Number of object entries
	0x01	Bit Mask for Bit 14	U32	rw	0x0	Device states that should be shown in the object 0x2324.01 (Device statusword)
	0x02	Bit Mask for Bit 15	U32	rw	0x0	Device states that should be shown in the object 0x2324.01 (Device statusword)

### Operation Mode Options (0x233F)

Index	Subindex	Name	Type	Attr.	Default value	Meaning
0x233F	0x00	OpMode Options	U16	rw	0x0001	Bit-coded

See chap. 5.1, p. 94.

### General Parameters (0x2340)

Index	Subindex	Name	Type	Attr.	Default value	Meaning
0x2340	0x00	Number of Entries	U8	ro	8	Number of object entries
	0x01	Commutation Type	U8	rw	3	Commutation type 0: Switched off 1: DC motor 2: BL motor with block commutation 3: BL motor with sine commutation
	0x02	Motor Output Voltage DC	S16	rw	-	Motor output voltage DC <sup>a)</sup>
	0x03	Motor Output Voltage BL Block	S16	rw	-	Motor output voltage, BL block <sup>a)</sup>
	0x04	Motor Output Voltage $X_d$	S16	rw	-	Motor output voltage $X_d$ <sup>a)</sup>
	0x05	Motor Output Voltage $X_q$	S16	rw	-	Motor output voltage $X_q$ <sup>a)</sup>
	0x06	Sinus Output Voltage $U_a$	U16	ro	-	Phase voltage $U_a$ <sup>a)</sup>
	0x07	Sinus Output Voltage $U_b$	U16	ro	-	Phase voltage $U_b$ <sup>a)</sup>
	0x08	Sinus Output Voltage $U_c$	U16	ro	-	Phase voltage $U_c$ <sup>a)</sup>

a) All voltages are in multiples of 10 mV

## Parameter description

### Target Voltage (0x2341)

Index	Subindex	Name	Type	Attr.	Default value	Meaning
0x2341	0x00	Voltage Mode Reference	S16	rw	0	Voltage set-point of the Voltage mode [10 mV / digit]

### Torque Control Parameters (0x2342)

Index	Subindex	Name	Type	Attr.	Default value	Meaning
0x2342	0x00	Number of Entries	U8	ro	2	Number of object entries
	0x01	Gain $K_{p,I}$	U32	rw	a)	Controller gain [mOhm]
	0x02	Integral Time $T_{N,I}$	U16	rw	a)	Controller reset time [ $\mu$ s], Range: 150–2600 $\mu$ s

a) Motor-specific, is set by the motor selection wizard.

### Flux Control Parameters (0x2343)

Index	Subindex	Name	Type	Attr.	Default value	Meaning
0x2343	0x00	Number of Entries	U8	ro	2	Number of object entries
	0x01	Gain $K_{p,I}$	U32	rw	a)	Controller gain [mOhm]
	0x02	Integral Time $T_{N,I}$	U16	rw	a)	Controller reset time [ $\mu$ s], Range: 150–2600 $\mu$ s

a) Motor-specific, is set by the motor selection wizard.

### Velocity Control Parameters (0x2344)

Index	Subindex	Name	Type	Attr.	Default value	Meaning
0x2344	0x00	Number of Entries	U8	ro	6	Number of object entries
	0x01	Gain $K_p$	U32	rw	a)	Controller gain [As $1e^{-6}$ ]
	0x02	Integral Time $T_N$	U16	rw	a)	Controller reset time [100 $\mu$ s]
	0x03	Velocity Deviation Threshold	U16	rw	65535	Maximum permissible control deviation
	0x04	Velocity Deviation Time	U16	rw	100	Maximal permissible duration of a control deviation outside the corridor
	0x05	Velocity Warning Threshold	U32	rw	30000	Warning threshold for the speed in user-defined units, see 0x2324.01 bit 21
	0x06	Integral part option	U8	rw	0	Configuration of the speed control loop: 0: Integral component active 1: Stopped integral component in the position window (in PP mode) 2: Integral component deactivated

a) Motor-specific, is set by the motor selection wizard.

## Parameter description

### Velocity Filter Parameters (0x2345)

Index	Subindex	Name	Type	Attr.	Default value	Meaning
0x2345	0x00	Number of Entries	U8	ro	2	Number of object entries
	0x01	Actual Velocity Filter $T_F$	U16	rw	a)	Filter time $T_F$ [100 $\mu$ s]
	0x02	Display Velocity Filter	U16	rw	20	Filter time for displaying the actual speed [100 $\mu$ s]

a) Motor-specific, is set by the motor selection wizard.

### Setpoint Velocity Filter Parameters (0x2346)

Index	Subindex	Name	Type	Attr.	Default value	Meaning
0x2346	0x00	Number of Entries	U8	ro	2	Number of object entries
	0x01	Setpoint Velocity Filter $T_F$	U16	rw	a)	Filter time $T_F$ [100 $\mu$ s]
	0x02	Setpoint Filter Enable	U8	rw	0	0: inactive 1: Active

a) Motor-specific, is set by the motor selection wizard.

### Gain scheduling (0x2347)

Index	Subindex	Name	Type	Attr.	Default value	Meaning
0x2347	0x00	Number of Entries	U8	ro	2	Number of object entries
	0x01	Gain Factor $K_p$	U8	rw	128	Gain factor (used by the speed control in PP mode on the $K_p$ ) 0: Reduction of the gain to 0 in the target 128: No variable gain 255: Doubling the gain in the target
	0x02	Gain Factor $K_v$	U8	rw	128	Gain factor (applied to $K_v$ in PP mode) 0: Reduction of the gain to 0 in the target 128: No variable gain 255: Doubling the gain in the target

### Position Control Parameters (0x2348)

Index	Subindex	Name	Type	Attr.	Default value	Meaning
0x2348	0x00	Number of Entries	U8	ro	1	Number of object entries
	0x01	Gain $K_v$	U8	rw	a)	Controller gain [1/s], range: 1–255

a) Motor-specific, is set by the motor selection wizard.

## Parameter description

### Current Feedforward Parameters (0x2349)

Index	Subindex	Name	Type	Attr.	Default value	Meaning
0x2349	0x00	Number of Entries	U8	ro	2	Number of object entries
	0x01	Current FeedForward Factor	U8	rw	0	Factor for the torque or force control 0: 0% activation of the feedforward control 128: 100% feedforward control
	0x02	Current FeedForward Delay	U16	rw	0	Set-point delay: 0: Undelayed activation 1: Activation delayed by one sampling

### Velocity Feedforward Parameters (0x234A)

Index	Subindex	Name	Type	Attr.	Default value	Meaning
0x234A	0x00	Number of Entries	U8	ro	2	Number of object entries
	0x01	Velocity Feedforward Factor	U8	rw	0	Factor for the torque or force control 0: 0% feedforward control 128: 100% feedforward control
	0x02	Velocity Feedforward Delay	U16	rw	0	Set-point delay: 0: Undelayed activation 1: Activation delayed by one sampling

### Current Filter Parameters (0x234B)

Index	Subindex	Name	Type	Attr.	Default value	Meaning
0x234B	0x00	Number of Entries	U8	ro	2	Number of object entries
	0x01	Display Motor Current Filter TF	U16	rw	200	Filter time for the display of the motor current [100 µs]
	0x02	Display torque filter	U16	rw	20	Filter time for the display of the torque [100 µs]

### Positive Torque Limit Homing (0x2350)

Index	Subindex	Name	Type	Attr.	Default value	Meaning
0x2350	0x00	Positive Torque Limit Homing	U16	rw	1000	Upper limit value for the reference run in 1/1000 of the rated motor torque

### Negative Torque Limit Homing (0x2351)

Index	Subindex	Name	Type	Attr.	Default value	Meaning
0x2351	0x00	Negative Torque Limit Homing	U16	rw	1000	Lower limit value for the reference run in 1/1000 of the rated motor torque

## Parameter description

### Actual Values (0x2360)

Index	Subindex	Name	Type	Attr	Default value	Meaning
0x2360	0x00	Number of Entries	U8	ro	8	Number of object entries
	0x01	Motor Current $I_d$ Actual Value <sup>a)</sup>	S16	ro	-	Motor current actual value ( $I_D$ )
	0x02	Motor Current $I_q$ Actual Value <sup>a)</sup>	S16	ro	-	Motor current actual value ( $I_q$ )
	0x03	Motor Current IBlock Actual Value <sup>a)</sup>	S16	ro	-	Motor current actual value (IBlock)
	0x04	Motor Current IDC Actual Value <sup>a)</sup>	S16	ro	-	Motor current actual value (IDC)
	0x05	Velocity Actual Internal Value	S16	ro	-	Speed actual value [ $\text{min}^{-1}$ ] (internal value)
	0x06	Position Actual Internal Value	S32	ro	-	Position actual value (internal value)

a) A value of 1000 corresponds to the device rated current set in object 2327.01

### Trace Configuration (0x2370)

Index	Subindex	Name	Type	Attr.	Default value	Meaning
0x2370	0x00	Number of Entries	U8	ro	10	Number of object entries
	0x01	Trigger Source	U32	wo	0	Trigger source
	0x02	Trigger Threshold	S32	rw	0	Trigger threshold
	0x03	Trigger Delay Offset	S16	rw	0	Trigger delay
	0x04	Trigger Mode	U16	rw	0	Trigger mode
	0x05	Buffer Length	U16	rw	100	Buffer length
	0x06	Sample Time	U8	rw	1	Recording sampling rate 1: in every sampling step
	0x07	Trace Source of Channel 1	U32	wo	0	Trace source of channel 1
	0x08	Trace Source of Channel 2	U32	wo	0	Trace source of channel 2
	0x09	Trace Source of Channel 3	U32	wo	0	Trace source of channel 3
	0x0A	Trace Source of Channel 4	U32	wo	0	Trace source of channel 4

## Parameter description

### Trace Buffer (0x2371)

Index	Subindex	Name	Type	Attr.	Default value	Meaning
0x2371	0x00	Number of Entries	U8	ro	5	Number of object entries
	0x01	Trace State	U16	ro	0	Trigger status
	0x02	Trace Value of Channel 1	Vis string	ro	–	Signal buffer, channel 1
	0x03	Trace Value of Channel 2	Vis string	ro	–	Signal buffer, channel 2
	0x04	Trace Value of Channel 3	Vis string	ro	–	Signal buffer, channel 3
	0x05	Trace Value of Channel 4	Vis string	ro	–	Signal buffer, channel 4

### Safety objects (0x2390)

Index	Subindex	Name	Type	Attr.	Default value	Meaning
0x2390	0x00	Number of Entries	U8	const	2	Number of object entries
	0x01	STO State	U8	ro	–	Status of the STO safety function (Safe Torque Off) 0: STO ON 1: Error 16: STO OFF 17: Powerdown
	0x02	STO Reset	U8	wo	–	STO reset pulse for changing to the operating state after an error 1: Activate reset

### Communication Parameter (0x2400)

Index	Subindex	Name	Type	Attr.	Default value	Meaning
0x2400	0x00	Number of Entries	U8	ro	7	Number of object entries
	0x01	CAN Rate	U8	rw	9	CAN rate (automatic baud rate determination)
	0x02	RS232 Rate	U8	rw	3	RS232 rate
	0x03	Node ID	U8	rw	1	Node number
	0x04	Communication Settings	U32	rw	0x00 03 03 02	Communication settings bit-coded: 0x00 00 00 01: CAN-NMT mandatory 0x00 00 00 02: Transmit async PDOs and EMCYs via CAN 0x00 00 01 00: Transmit EMCYs via USB 0x00 00 02 00: Transmit async Messages via USB 0x00 01 00 00: Transmit EMCYs via RS232 0x00 02 00 00: Transmit async Messages via RS232 0x00 80 00 00: Ignore CRC
	0x05	RS232 Net Mode	U8	rw	0	RS232 net mode
	0x08	Explicit Device ID	U16	rw	0	Identification of the drive



## Parameter description

### Internal Filter Parameters (0x2502)

Index	Subindex	Name	Type	Attr.	Default value	Meaning
0x2502	0x00	Number of entries	U8	ro	13	Number of object entries
	0x01	Filter Time Actual Velocity	U16	rw	256	Filter time, effective on the value in 0x2360.05.

### Boot Options (0x2503)

Index	Subindex	Name	Type	Attr.	Default value	Meaning
0x2503	0x00	Boot Options	U16	rw	1	0: Current measurement is not adjusted 1: Current measurement is adjusted during system start

## Parameter description

### 8.2 Objects of the drive profile acc. to CiA 402

#### Abort Connection Option Code (0x6007)

Index	Subindex	Name	Type	Attr.	Default value	Meaning
0x6007	0x00	Abort Connection Option Code	S16	rw	1	Reaction of the controller in the event of losing connection: 0: No reaction 1: Switch into fault state 2: Switch into the <i>Switch On Disabled</i> state 3: Switch into the <i>Quick-Stop</i> state

See chap. 7.2.1, p. 160.

#### Controlword (0x6040)

Index	Subindex	Name	Type	Attr.	Default value	Meaning
0x6040	0x00	Controlword	U16	rw	0	Controlword

See chap. 3.2, p. 17.

#### Statusword (0x6041)

Index	Subindex	Name	Type	Attr.	Default value	Meaning
0x6041	0x00	Statusword	U16	ro	0	Statusword

See chap. 3.3, p. 20.

#### Quick Stop Option Code (0x605A)

**i** When the drive exits the *Operation Enabled* state, the motor can be stopped prior to this. The option codes (object 0x605A to 0x605E) define the behavior at the transition (see CiA 402 and chap. 3.4, p. 22)

Index	Subindex	Name	Type	Attr.	Default value	Meaning
0x605A	0x00	Quick Stop Option Code	S16	rw	2	Halt options for the <b>Quick Stop</b> command

#### Shut Down Option Code (0x605B)

Index	Subindex	Name	Type	Attr.	Default value	Meaning
0x605B	0x00	Shut Down Option Code	S16	rw	0	Halt options for the <b>Shut Down</b> command

See chap. 3.4, p. 22.

#### Disable Operation Option Code (0x605C)

Index	Subindex	Name	Type	Attr.	Default value	Meaning
0x605C	0x00	Disable Operation Option Code	S16	rw	1	Halt options for the <b>Disable Operation</b> command

See chap. 3.4, p. 22.

## Parameter description

### Halt Option Code (0x605D)

Index	Subindex	Name	Type	Attr.	Default value	Meaning
0x605D	0x00	Halt Option Code	S16	rw	1	Halt options when setting the halt bit in the controlword

See chap. 3.4, p. 22.

### Fault Reaction Option Code (0x605E)

Index	Subindex	Name	Type	Attr.	Default value	Meaning
0x605E	0x00	Fault Reaction Option Code	S16	rw	2	Halt options at the transition into a fault state

See chap. 3.4, p. 22.

### Modes of Operation (0x6060)

Index	Subindex	Name	Type	Attr.	Default value	Meaning
0x6060	0x00	Modes of Operation	S8	rw	0	Select the operating mode -4: ATC -3: AVC -2: APC -1: Voltage mode 0: Controller not activated 1: PP 3: PV 6: Homing 8: CSP 9: CSV 10: CST

See chap. 5, p. 92.

### Modes of Operation Display (0x6061)

Index	Subindex	Name	Type	Attr.	Default value	Meaning
0x6061	0x00	Modes of Operation Display	S8	ro	–	Display of the selected operating mode

See chap. 5, p. 92.

### Position Demand Value (0x6062)

Index	Subindex	Name	Type	Attr.	Default value	Meaning
0x6062	0x00	Position Demand Value	S32	ro	–	Position set-point in user-defined units

See chap. 4.4, p. 43.

### Position Actual Internal Value (0x6063)

Index	Subindex	Name	Type	Attr.	Default value	Meaning
0x6063	0x00	Position Actual Internal Value	S32	ro	–	Position actual value in internal units

## Parameter description

### Position Actual Value (0x6064)

Index	Subindex	Name	Type	Attr.	Default value	Meaning
0x6064	0x00	Position Actual Value	S32	ro	–	Position actual value in user-defined units

See chap. 4.4, p. 43.

### FollowingError window (0x6065)

Index	Subindex	Name	Type	Attr.	Default value	Meaning
0x6065	0x00	FollowingError Window	U32	rw	32	Corridor for the control deviation of the position controller in user-defined units

See chap. 5, p. 92.

### FollowingError time out (0x6066)

Index	Subindex	Name	Type	Attr.	Default value	Meaning
0x6066	0x00	FollowingError Time Out	U16	rw	48	Minimum time for which a following error must lie outside the defined corridor before the error is reported

See chap. 5, p. 92.

### Position Window (0x6067)

Index	Subindex	Name	Type	Attr.	Default value	Meaning
0x6067	0x00	Position Window	U32	rw	32	Corridor around the target position in user-defined units

See chap. 5, p. 92.

### Position Window Time (0x6068)

Index	Subindex	Name	Type	Attr.	Default value	Meaning
0x6068	0x00	Position Window Time	U16	rw	48	Minimum residence time within the corridor in PP operating mode, until the target position is reported as achieved.

See chap. 5, p. 92.

### Velocity Demand Value (0x606B)

Index	Subindex	Name	Type	Attr.	Default value	Meaning
0x606B	0x00	Velocity Demand Value	S32	ro	–	Set-point of the speed in user-defined units

See chap. 4.4, p. 43.

### Velocity Actual Value (0x606C)

Index	Subindex	Name	Type	Attr.	Default value	Meaning
0x606C	0x00	Velocity Actual Value	S32	ro	–	Speed actual value in user-defined units

See chap. 4.4, p. 43.

## Parameter description

### Velocity Window (0x606D)

Index	Subindex	Name	Type	Attr.	Default value	Meaning
0x606D	0x00	Velocity Window	U16	rw	32	Corridor around the set speed in user-defined units

See chap. 4.3.4, p. 31.

### Velocity Window Time (0x606E)

Index	Subindex	Name	Type	Attr.	Default value	Meaning
0x606E	0x00	Velocity Window Time	U16	rw	48	Minimum residence time within the corridor in ms

See chap. 4.3.4, p. 31.

### Velocity Threshold (0x606F)

Index	Subindex	Name	Type	Attr.	Default value	Meaning
0x606F	0x00	Velocity Threshold	U16	rw	32	Corridor at $n = 0$ in user-defined units

See chap. 4.3.4, p. 31.

### Velocity Threshold Time (0x6070)

Index	Subindex	Name	Type	Attr.	Default value	Meaning
0x6070	0x00	Velocity Threshold Time	U16	rw	48	Monitoring time [ms]. If the speed lies outside the corridor for longer than is listed here, the speed is reported as not equal to 0.

See chap. 4.3.4, p. 31.

### Target Torque (0x6071)

Index	Subindex	Name	Type	Attr.	Default value	Meaning
0x6071	0x00	Target Torque	S16	rw	0	Set-point of the torque in relative scaling <sup>a)</sup>

a) 1000 = motor rated torque

See chap. 5.7, p. 137.

### Maximum Torque (0x6072)

Index	Subindex	Name	Type	Attr.	Default value	Meaning
0x6072	0x00	Maximum Torque	U16	rw	6000	Torque limitation in relative scaling <sup>a)</sup>

a) 1000 = motor rated torque

See chap. 5, p. 92.

### Torque Demand (0x6074)

Index	Subindex	Name	Type	Attr.	Default value	Meaning
0x6074	0x00	Torque Demand	S16	ro	0	Set-point of the torque (value from the speed profile) in relative scaling <sup>a)</sup>

a) 1000 = motor rated torque

See chap. 4.4, p. 43.

## Parameter description

### Torque Actual Value (0x6077)

Index	Subindex	Name	Type	Attr.	Default value	Meaning
0x6077	0x00	Torque Actual Value	S16	ro	0	Actual value of the torque in relative scaling <sup>a)</sup>

a) 1000 = motor rated torque

See chap. 4.4, p. 43.

### Current Actual Value (0x6078)

Index	Subindex	Name	Type	Attr.	Default value	Meaning
0x6078	0x00	Current Actual Value	S16	ro	0	Actual value of the current in relative scaling <sup>a)</sup>

a) 1000 = motor rated current

### Target Position (0x607A)

Index	Subindex	Name	Type	Attr.	Default value	Meaning
0x607A	0x00	Target Position	S32	rw	0	Position set-point in user-defined units

See chap. 4.4, p. 43.

### Position Range Limit (0x607B)

Index	Subindex	Name	Type	Attr.	Default value	Meaning
0x607B	0x00	Number of Entries	U8	ro	2	Number of object entries
	0x01	Min Position Range Limit	S32	rw	-2147483648	Lower limit of the position range in user-defined units
	0x02	Max Position Range Limit	S32	rw	2147483647	Upper limit of the position range in user-defined units

See chap. 5, p. 92.

### Homing Offset (0x607C)

Index	Subindex	Name	Type	Attr.	Default value	Meaning
0x607C	0x00	Homing Offset	S32	rw	0	Offset of the zero position relative to the position of the reference switch in user-defined units

See chap. 5.4, p. 117.

### Software Position Limit (0x607D)

Index	Subindex	Name	Type	Attr.	Default value	Meaning
0x607D	0x00	Number of Entries	U8	ro	2	Number of object entries
	0x01	Min Position Limit	S32	rw	-2147483648	Lower limit of the position range in user-defined units
	0x02	Max Position Limit	S32	rw	2147483647	Upper limit of the position range in user-defined units

See chap. 5, p. 92.

## Parameter description

### Polarity (0x607E)

Index	Subindex	Name	Type	Attr.	Default value	Meaning
0x607E	0x00	Polarity	U8	rw	0	Bit-coded

See chap. 4.8.6, p. 70.

### Maximum Motor Speed (0x6080)

Index	Subindex	Name	Type	Attr.	Default value	Meaning
0x6080	0x00	Maximum Motor Speed	U32	rw	32767	Maximum speed of the motor in user-defined units

See chap. 4.3.4, p. 31.

### Profile Velocity (0x6081)

Index	Subindex	Name	Type	Attr.	Default value	Meaning
0x6081	0x00	Profile Velocity	U32	rw	32767	Profile velocity in user-defined units

See chap. 4.4, p. 43.

### Profile Acceleration (0x6083)

Index	Subindex	Name	Type	Attr.	Default value	Meaning
0x6083	0x00	Profile Acceleration	U32	rw	30000	Acceleration [ $1/s^2$ ]

See chap. 4.4, p. 43.

### Profile Deceleration (0x6084)

Index	Subindex	Name	Type	Attr.	Default value	Meaning
0x6084	0x00	Profile Deceleration	U32	rw	30000	Braking rate [ $1/s^2$ ]

See chap. 4.4, p. 43.

### Quick Stop Deceleration (0x6085)

Index	Subindex	Name	Type	Attr.	Default value	Meaning
0x6085	0x00	Quick Stop Deceleration	U32	rw	30000	Quick-Stop deceleration [ $1/s^2$ ]

See chap. 7.2.1, p. 160.

### Motion Profile Type (0x6086)

Index	Subindex	Name	Type	Attr.	Default value	Meaning
0x6086	0x00	Motion Profile Type	S16	rw	0	Speed profile type: 0: Linear profile 1: $\text{Sin}^2$ speed

See chap. 4.4, p. 43.

## Parameter description

### Position Encoder Resolution (0x608F)

Index	Subindex	Name	Type	Attr.	Default value	Meaning
0x608F	0x00	Number of Entries	U8	ro	2	Number of object entries
	0x01	Encoder Increments	U32	ro	4096	Encoder increments
	0x02	Motor Revolutions	U32	ro	1	Motor revolutions

See chap. 4.8.1, p. 67.

### Velocity Encoder Resolution (0x6090)

Index	Subindex	Name	Type	Attr.	Default value	Meaning
0x6090	0x00	Number of Entries	U8	ro	2	Number of object entries
	0x01	Encoder Increments	U32	ro	4096	Position resolution of the set sensor
	0x02	Motor Revolutions	U32	ro	1	Number of motor revolutions for the impulse number specified in subindex 1

See chap. 4.8.2, p. 68.

### Gear Ratio (0x6091)

Index	Subindex	Name	Type	Attr.	Default value	Meaning
0x6091	0x00	Number of Entries	U8	ro	2	Number of object entries
	0x01	Motor Shaft Revolutions	U32	ro	1	Revolutions of the gearhead input shaft
	0x02	Driving Shaft Revolutions	U32	rw	1	Revolutions of the gearhead output shaft

See chap. 4.8.4, p. 69.

### Feed Constant (0x6092)

Index	Subindex	Name	Type	Attr.	Default value	Meaning
0x6092	0x00	Number of Entries	U8	ro	2	Number of object entries
	0x01	Feed	U32	rw	4096	Feed
	0x02	Shaft Revolutions	U32	rw	1	Revolutions

See chap. 4.8.5, p. 70.

### Velocity Factor (0x6096)

Index	Subindex	Name	Type	Attr.	Default value	Meaning
0x6096	0x00	Number of Entries	U8	ro	2	Number of object entries
	0x01	Numerator	U32	rw	1	Numerator
	0x02	Divisor	U32	rw	4096	Denominator

See chap. 4.8.3, p. 68.

### Homing Method (0x6098)

Index	Subindex	Name	Type	Attr.	Default value	Meaning
0x6098	0x00	Homing Method	S8	rw	0	Homing method

See chap. 5.4, p. 117.



## Parameter description

### Homing Speeds (0x6099)

Index	Subindex	Name	Type	Attr.	Default value	Meaning
0x6099	0x00	Number of Entries	U8	ro	2	Number of object entries
	0x01	Switch Seek Velocity	U32	rw	400	Speed during search for switch
	0x02	Homing Speed	U32	rw	400	Speed during search for zero

See chap. 5.4, p. 117.

### Homing Acceleration (0x609A)

Index	Subindex	Name	Type	Attr.	Default value	Meaning
0x609A	0x00	Homing Acceleration	U32	rw	50	Acceleration during homing

See chap. 5.4, p. 117.

### Position Offset (0x60B0)

Index	Subindex	Name	Type	Attr.	Default value	Meaning
0x60B0	0x00	Position Offset	S32	rw	0	Position offset in user-defined units

See chap. 5.5, p. 128.

### Velocity Offset (0x60B1)

Index	Subindex	Name	Type	Attr.	Default value	Meaning
0x60B1	0x00	Velocity Offset	S32	rw	0	Velocity offset in user-defined units

See chap. 5.5, p. 128 and chap. 5.6, p. 134.

### Torque Offset (0x60B2)

Index	Subindex	Name	Type	Attr.	Default value	Meaning
0x60B2	0x00	Torque Offset	S16	rw	0	Torque Offset with relative scaling

See chap. 5.5, p. 128, chap. 5.6, p. 134 and chap. 5.7, p. 137.

### Touch Probe Function (0x60B8)

Index	Subindex	Name	Type	Attr.	Default value	Meaning
0x60B8	0x00	Touch Probe Function	U16	rw	0	Touch probe function

See chap. 4.9.4, p. 80.

### Touch Probe Status (0x60B9)

Index	Subindex	Name	Type	Attr.	Default value	Meaning
0x60B9	0x00	Touch Probe Status	U16	ro	0	Touch probe status

See chap. 4.9.4, p. 80.

### Touch Probe 1 Positive Edge (0x60BA)

Index	Subindex	Name	Type	Attr.	Default value	Meaning
0x60BA	0x00	Touch Probe 1 Positive Edge	S32	ro	0	Touch probe position 1 positive value in user-defined units

See chap. 4.9.4, p. 80.

## Parameter description

### Touch Probe 1 Negative Edge (0x60BB)

Index	Subindex	Name	Type	Attr.	Default value	Meaning
0x60BB	0x00	Touch Probe 1 Negative Edge	S32	ro	0	Touch probe position 1 negative value in user-defined units

See chap. 4.9.4, p. 80.

### Touch Probe 2 Positive Edge (0x60BC)

Index	Subindex	Name	Type	Attr.	Default value	Meaning
0x60BC	0x00	Touch Probe 2 Positive Edge	S32	ro	0	Touch probe position 2 positive value in user-defined units

See chap. 4.9.4, p. 80.

### Touch Probe 2 Negative Edge (0x60BD)

Index	Subindex	Name	Type	Attr.	Default value	Meaning
0x60BD	0x00	Touch Probe 2 Negative Edge	S32	ro	0	Touch probe position 2 negative value in user-defined units

See chap. 4.9.4, p. 80.

### Maximum Acceleration (0x60C5)

Index	Subindex	Name	Type	Attr.	Default value	Meaning
0x60C5	0x00	Maximum Acceleration	U32	rw	30000	PP mode or PV mode maximum acceleration [ $1/s^2$ ]

### Maximum Deceleration (0x60C6)

Index	Subindex	Name	Type	Attr.	Default value	Meaning
0x60C6	0x00	Maximum Deceleration	U32	rw	30000	PP mode or PV mode maximum braking rate [ $1/s^2$ ]

### Touch Probe 1 Positive Edge Counter (0x60D5)

Index	Subindex	Name	Type	Attr.	Default value	Meaning
0x60D5	0x00	Touch Probe 1 Positive Edge Counter	U16	ro	–	Counter of the positive edges at input 1

See chap. 4.9.4, p. 80.

### Touch Probe 1 Negative Edge Counter (0x60D6)

Index	Subindex	Name	Type	Attr.	Default value	Meaning
0x60D6	0x00	Touch Probe 1 Negative Edge Counter	U16	ro	–	Counter of the negative edges at input 1

See chap. 4.9.4, p. 80.

### Touch Probe 2 Positive Edge Counter (0x60D7)

Index	Subindex	Name	Type	Attr.	Default value	Meaning
0x60D7	0x00	Touch Probe 2 Positive Edge Counter	U16	ro	–	Counter of the positive edges at input 2

See chap. 4.9.4, p. 80.

## Parameter description

### Touch Probe 2 Negative Edge Counter (0x60D8)

Index	Subindex	Name	Type	Attr.	Default value	Meaning
0x60D8	0x00	Touch Probe 2 Negative Edge Counter	U16	ro	–	Counter of the negative edges at input 2

See chap. 4.9.4, p. 80.

### Positive Torque Limit Value (0x60E0)

Index	Subindex	Name	Type	Attr.	Default value	Meaning
0x60E0	0x00	Positive Torque Limit Value	U16	rw	6000	Upper limit value in relative scaling <sup>a)</sup>

a) 1000 = motor rated torque

See chap. 6.2, p. 153.

### Negative Torque Limit Value (0x60E1)

Index	Subindex	Name	Type	Attr.	Default value	Meaning
0x60E1	0x00	Negative Torque Limit Value	U16	rw	6000	Lower limit value in relative scaling <sup>a)</sup>

a) 1000 = motor rated torque

See chap. 6.2, p. 153.

### Position Option Code (0x60F2)

Index	Subindex	Name	Type	Attr.	Default value	Meaning
0x60F2	0x00	Position Option Code	U16	rw	0	Behavior of the drive during cyclical rotary movements

See chap. 5.5.5, p. 132.

### FollowingError Actual Value (0x60F4)

Index	Subindex	Name	Type	Attr.	Default value	Meaning
0x60F4	0x00	FollowingError Actual Value	U32	ro	0	Deviation between position set-point and position actual value

See chap. 5.5, p. 128 and chap. 5.9, p. 143.

### Digital Inputs (0x60FD)

Index	Subindex	Name	Type	Attr.	Default value	Meaning
0x60FD	0x00	Digital Inputs	U32	ro	–	Bit-coded: Bits 0...1: Reserved Bit 2: RefInput Status Bits 3...15: Reserved Bits 16...23: DigIn1...DigIn8 status

### Target Velocity (0x60FF)

Index	Subindex	Name	Type	Attr.	Default value	Meaning
0x60FF	0x00	Target Velocity	S32	rw	0	Speed set-point in user-defined units

## Parameter description

### Motor Catalogue Number (0x6403)

Index	Subindex	Name	Type	Attr.	Default value	Meaning
0x6403	0x00	Motor Catalogue Number	Vis string	rw	0	Motor number

### Supported Drive Modes (0x6502)

Index	Subindex	Name	Type	Attr.	Default value	Meaning
0x6502	0x00	Supported Drive Modes	U32	ro	Bit-coded, see CiA 402	Supported operating modes

### Drive Catalogue Number (0x6503)

Index	Subindex	Name	Type	Attr.	Default value	Meaning
0x6503	0x00	Drive Catalogue Number	Vis string	const	0	FAULHABER identification number of the Motion Controller

